

**UPDATE
GEOTECHNICAL REPORT**

**OTAY RANCH VILLAGE 8 EAST
CHULA VISTA, CALIFORNIA**



GEOCON
INCORPORATED

GEOTECHNICAL
ENVIRONMENTAL
MATERIALS

PREPARED FOR



HOMEFED
CORPORATION

**PROJECT NO. G1006-52-05
SEPTEMBER 30, 2022
REVISED MAY 5, 2023**



Project No. G1006-52-05
September 30, 2022
Revised May 5, 2023

Homefed Otay Land II, LLC
1903 Wright Place, Suite 220
Carlsbad, California 92008

Attention: Mr. Jeff O'Connor

Subject: UPDATE GEOTECHNICAL REPORT
OTAY RANCH VILLAGE 8 EAST
CHULA VISTA, CALIFORNIA

Dear Mr. O'Connor:

In accordance with your authorization and our proposal LG-21228 dated May 4, 2021, we prepared this update geotechnical report for the subject project. The accompanying report presents our findings, conclusions and recommendations pertaining to the geotechnical aspects of the proposed development. The study also includes an evaluation of the geologic units and geologic hazards. Based on the results of this study, we opine the site is considered suitable for development provided the recommendations of this report are followed.

Should you have any questions regarding this correspondence, or if we may be of further service, please contact the undersigned at your convenience.

Very truly yours,

GEOCON INCORPORATED

Shawn Foy Weedon
GE 2714



Michael C. Ertwine
CEG 2659



SFW:MCE:am

(e-mail) Addressee
(e-mail) Hunsaker & Associates San Diego, Inc.
Attention: Ms. Alisa Vialpando

TABLE OF CONTENTS

1.	PURPOSE AND SCOPE	1
2.	SITE AND PROJECT DESCRIPTION	2
3.	PREVIOUS SITE DEVELOPMENT	5
4.	TEMPORARY GRADED SLOPES	6
5.	SUBDRAINS	7
6.	GEOLOGIC SETTING.....	8
7.	SOIL AND GEOLOGIC CONDITIONS	9
7.1	Previously Placed Fill (Qpf)	9
7.2	Undocumented Fill Soil (Qudf – Environmental Stockpile)	10
7.3	Undocumented Fill Soil (Qudf).....	10
7.4	Compacted Fill (Qcf).....	10
7.5	Topsoil (unmapped).....	11
7.6	Alluvium (Qal)	11
7.7	Terrace Deposits (Qt)	11
7.8	Otay Formation (To, Tob and Tog)	11
8.	GEOLOGIC STRUCTURE	12
9.	GROUNDWATER	12
10.	GEOLOGIC HAZARDS	13
10.1	Faulting and Seismicity	13
10.2	Liquefaction.....	14
10.3	Landsliding	14
10.4	Seiches and Tsunamis.....	15
10.5	Slope Stability.....	15
10.6	Erosion.....	16
11.	CONCLUSIONS AND RECOMMENDATIONS.....	17
11.1	General.....	17
11.2	Existing Grade Soil Conditions	18
11.3	Seismic Design Criteria – 2022 California Building Code.....	19
11.4	Slope Stability Analyses.....	22
11.5	Grading.....	23
11.6	Earthwork Grading Factors.....	30
11.7	Subdrains	30
11.8	Preliminary Foundation and Concrete Slabs-On-Grade Recommendations.....	33
11.9	Exterior Concrete Flatwork	39
11.10	Conventional Retaining Walls.....	40
11.11	Lateral Loading.....	43
11.12	Preliminary Pavement Recommendations	44
11.13	Slope Maintenance.....	47
11.14	Site Drainage and Moisture Protection.....	48
11.15	Grading and Foundation Plan Review	49
11.16	Testing and Observation Services During Construction.....	49

TABLE OF CONTENTS (Concluded)

LIMITATIONS AND UNIFORMITY OF CONDITIONS

MAPS AND ILLUSTRATIONS

Figures 1 through 6, Geologic Map
Figures 7 and 8, Geologic Cross-Sections

APPENDIX A

PREVIOUS BORINGS AND TRENCH LOGS

APPENDIX B

LABORATORY TESTING

Table B-I, Summary of Laboratory Maximum Dry Density and Optimum Moisture Content Test Results
Table B-II, Summary of Laboratory Direct Shear Test Results
Table B-III, Summary of Laboratory Expansion Index Test Results
Table B-IV, Summary of Laboratory Water-Soluble Sulfate Test Results
Table B-V, Summary of Laboratory Atterberg Limits Test Results
Table B-VI, Summary of Laboratory Resistance Value (R-Value) Results
Figures B-1, Gradation Curve

APPENDIX C

SLOPE STABILITY ANALYSIS

APPENDIX D

RECOMMENDED GRADING SPECIFICATIONS

LIST OF REFERENCES

UPDATE GEOTECHNICAL REPORT

1. PURPOSE AND SCOPE

This report presents the results of an update geotechnical study for the proposed Otay Ranch Village 8 East development located in eastern portion of Chula Vista, California (see Vicinity Map).



Vicinity Map

The purpose of this update report is to provide excavation and remedial grading considerations, foundation and concrete slab-on-grade recommendations, retaining wall and lateral load recommendations, 2019 CBC seismic design criteria, preliminary pavement and flatwork recommendations, and discussions regarding the local geologic hazards including faulting, liquefaction, and seismic shaking. The scope of the study also included a review of:

1. *Geotechnical Investigation, Otay Ranch Village 8 East, Chula Vista, California*, prepared by Geocon Incorporated, dated March 14, 2014 (Project No. G1006-11-02).
2. *Final Report of Testing and Observation Services Performed During Site Grading, Otay Ranch Village 8 East, Borrow and Disposal Sites, Chula Vista, California*, prepared by Geocon Incorporated, dated September 9, 2022 (Project No. G1006-52-04).
3. *Tentative Map CVT-13-03, Otay Ranch Village 8 East, City of Chula Vista*, prepared by Hunsaker & Associates, San Diego, Inc., August 17, 2022 (W.O. No. 2395-0039).

Our referenced field investigation dated March 14, 2014 for Otay Ranch Village 8 East included mapping the geology, drilling 19 large-diameter borings, and excavating 57 backhoe trenches. Appendix A presents the logs of the previous borings and trenches. The approximate locations of the exploratory excavations are presented on the Geologic Map (Figures 1 through 6). We performed laboratory tests on soil samples obtained from the exploratory excavations to evaluate pertinent physical and chemical properties for engineering analysis. The results of the laboratory testing are presented in Appendix B. We performed engineering analyses to evaluate the stability of the proposed slopes. The results of our slope stability analyses are discussed herein and analyses are presented in Appendix C.

Hunsaker & Associates San Diego, Inc. provided the topographic information and the tentative map used during our field investigation and preparation of the Geologic Map. References to elevations presented in this report are based on the referenced topographic information. Geocon does not practice in the field of land surveying and is not responsible for the accuracy of such topographic information.

2. SITE AND PROJECT DESCRIPTION

Otay Ranch Village 8 East is located south of future Main Street (currently Rock Mountain Road) and Olympian High School, west of State Route 125, north of the Otay River drainage and Wiley Road access easement, and east of undeveloped land in the southeastern portion of Chula Vista, California. The property is approximately 575 gross acres with about 265 gross acres planned for open space resulting in the development of about 310 acres. The site consists of a series of south trending ridges and canyons draining to the south into Otay River. Site elevations range from approximately 180 feet above mean sea level (MSL) at the southwest corner of the Community Park site adjacent to the Otay River drainage to approximately 610 feet MSL at the northeast corner of the site. Cut and fill slopes exist on the northern portion of the site created during the previous grading of Main Street. A Chula Vista sewer line easement and SDG&E overhead transmission lines are located on the southern portion of the project within the un-improved Wiley Road. Wiley Road provides access to the Vulcan material plant to the west and further east within the Otay River Valley. The City of San Diego's, Otay 2nd 40-inch and Otay 3rd 54-inch waterlines (constructed in the late 1920s by cut and cover techniques) cross the site from east to west in the middle portion of the project. We understand the invert elevations of the pipeline are 10 to 15 below the existing grades based on observation of portion of mass grading on Village 8 West. We understand the existing waterlines will be removed or abandoned from the eastern and western points of connection, respectively. Portions of the existing 54-inch pipeline are partially exposed above ground as it crosses several tributary drainages. Previous grading of Main Street and the high school included the construction of canyon subdrains and a buttress fill. Site vegetation consists of sparse native coastal sage scrub and grassland habitats disturbed by farming. Some riparian vegetation occurs on the north side of the Otay River drainage area. The Project Location Map shows the areas surrounding the Village 8 West development area.



Project Location Map

We understand the development will generally occur from the north to south property lines leaving local areas designated as open space and preserve for environmental purposes (MSCP). The site will accommodate multi-family residential (108.8), village core (47.7 acres), park sites (73.2 acres), school site (11.3 acres), community purpose facilities (2.0 acres), parks (73.2 acres, respectively), future development lots (9.3 acres), circulation roadways (31.8 acres), active recreation (22.6 acres), and open space (253.6 acres of preserve land, and basins (31.6 acres). A large community park is proposed on the southern portion of the property adjacent to the Otay River drainage channel. In addition, a water quality basin will be constructed on the southeast and southwest portion of the site to the south of the developed area and along the north side of the Otay River drainage. Grading of the site will consist of maximum cuts and fills of approximately 75 feet with cut and fill slopes having a maximum height of 45 and 50 feet, respectively, and a maximum slope inclination of 2:1 (horizontal to vertical). Several reinforced earth retaining walls are proposed on the site with maximum heights on the order of 25 feet. The proposed grading will require approximately 4.86 million cubic yards of excavation and fill. The Site Utilization plan is presented herein. This report does not include the design for the proposed bridges extending over Highway SR-125 on La Media Parkway and Rock Mountain Road.

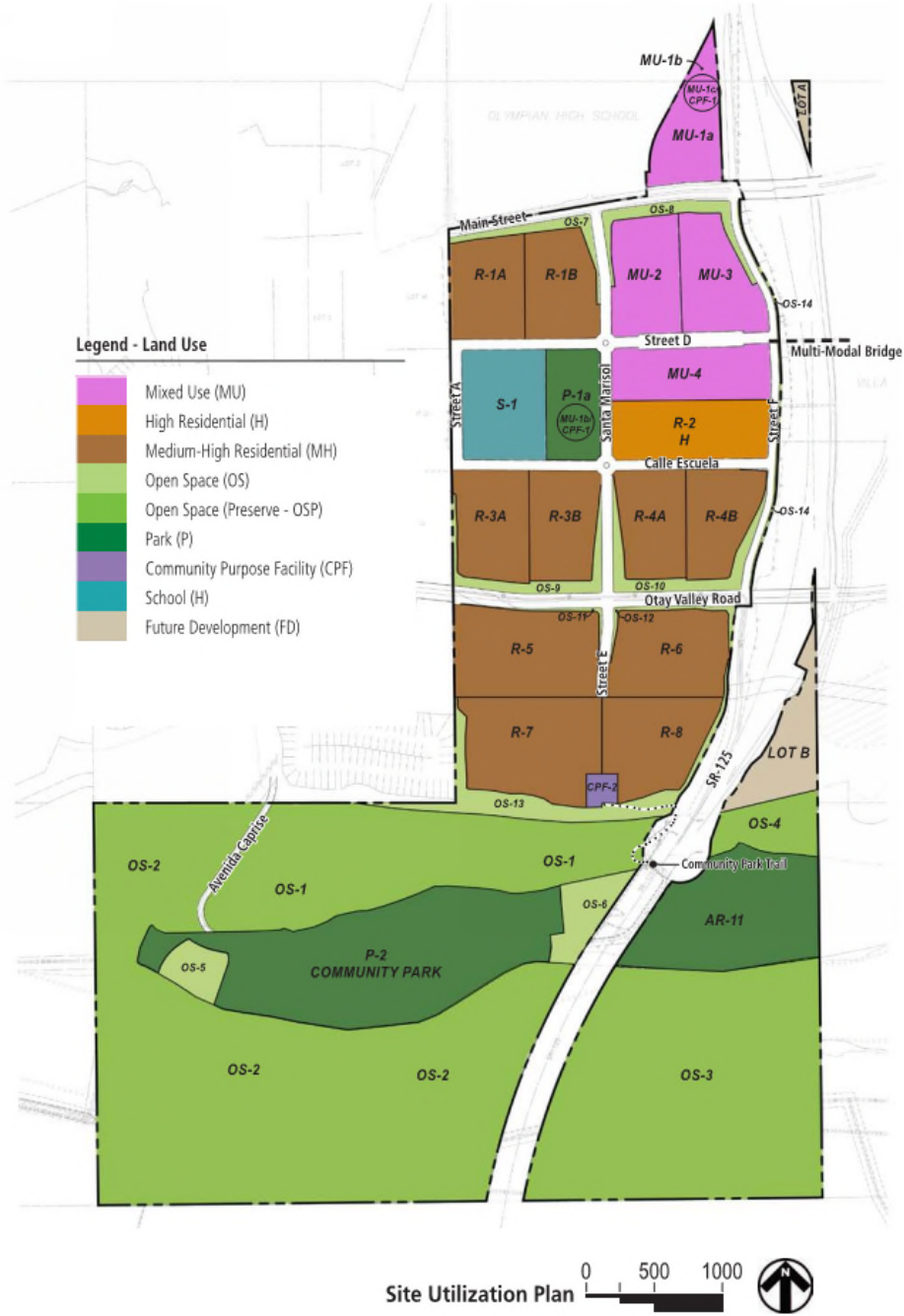

Site Utilization Map

A portion of Village 8 East has been utilized as a disposal site for rock-fill placement operations which are ongoing. Prior to site grading in the disposal area, in accordance with the soil remediation plan, topsoil material was stripped and stockpiled. The stockpiled material will be placed during mass-grading operations in accordance with project specifications. Within the disposal site, remedial grading consisted of removing the existing surficial materials in the proposed work area, installing subdrains (where

necessary) and placing soil-rock-fill from the Otay Ranch Village 8 West project. The rock is being placed on the side of an existing slope to an elevation of about 425 to 440 feet MSL. The rock will be placed at least 2 feet below the planned deepest utilities and at least 10 feet from the proposed finish grade elevations. Soil: rock-fill is placement is completed and referenced in our report dated August 9, 2022.

The locations and descriptions provided herein are based on a site reconnaissance, review of the tentative map, and project information provided by the client and Hunsaker & Associates, San Diego.

3. PREVIOUS SITE DEVELOPMENT

In general, a portion of Otay Ranch Village 8 East has been partially grading during mass grading operations for Village 8 West. The disposal and borrow areas within Village 8 West consisted of remedial grading of surficial soil and placing compacted fill resulting in a total maximum thickness ranging up to approximately 40 feet. The surficial soil (topsoil) and upper weathered formational materials were excavated to expose competent Otay Formation. The topsoil and portions of the weathered Otay Formation were stockpiled for environmental purposes highlighted blue and labeled environmental stockpile. Prior to fill placement, toe drains were installed and canyon subdrains were placed within the former canyon drainages. The grading contractor generated additional fill material from within the Otay Formation and placed within the lower temporary slope zone margins subsequent to the installation of the toe drains. Excavation depths ranged from 5 feet within the former mesa areas and up to 10 feet within the flanks of the central canyon drainage. The Geologic Maps, Figures 1 through 8, depict elevations of the base of the fill and environmental stockpiled material.

Imported materials from Otay Ranch Village 8 West generally varied between angular gravels and boulders (produced by blasting of hard metavolcanic rock) to clayey, fine sand; sandy to silty clay; and sandy to clayey gravels. Structural fill consists of materials that can be classified into three zones:

1. *Zone A* – Material placed within 3 feet of pad grade, 6 feet of parkway grade, and within roadways to at least 1 foot below the deepest utility consisted of “soil” fill with a maximum particle dimension of 6 inches.
2. *Zone B* – Material placed within 10 feet of pad grade and below *Zone A* consisted of “soil-rock” fill with a maximum particle dimension of 12 inches. In addition, material placed on the outer 6 feet of fill slopes and 2 feet below *Zone A* for fills in roadways and parkways consisted of “soil-rock” fill with a maximum particle dimension of 12 inches.
3. *Zone C* – Material placed below *Zone B* consisted of “soil-rock” fill and “rock” fill with a maximum particle dimension of 4 feet. It should also be noted that larger rocks with a maximum dimension of approximately 8 feet were buried individually during “soil-rock” fill grading operations.

Based on our observations, only Zones B and C were placed in the disposal areas. We expect Zone A will be placed during future mass grading operations during site development. Placement procedures for “soil-rock” and “rock” fills consisted of spreading and compacting the material with a D9 or larger Caterpillar bulldozer with a maximum lift size of 3 feet. Materials placed as “soil/rock” and “rock” fills were watered heavily during spreading to place finer-grained material between the rocks. During the placement of each lift, compaction effort was applied to the fill by wheel-rolling with loaded rock trucks such that the entire lift was compacted.

Soil fills were placed in lifts no thicker than would allow for adequate bonding and compaction. The soil was moisture conditioned as necessary and mixed during placement, then compacted utilizing conventional heavy-duty compaction equipment.

During the disposal sites grading operations, we observed compaction procedures and performed in-place density tests to evaluate the dry density and moisture content of the fill materials. We performed in-place density tests in general conformance with ASTM Test Method D 6938 (nuclear). In general, the in-place density test results indicate the compacted fill possesses a dry density of at least 90 percent of the laboratory maximum dry density near to slightly above optimum moisture content at the locations tested. The results of these tests are reported in the referenced Final Report of Grading dated September 9, 2022. A summary of the observations, compaction test results, and professional opinions pertaining to the grading is presented in the referenced interim reports of testing and observation services performed during site grading.

4. TEMPORARY GRADED SLOPES

During the disposal site grading operations, the contractor constructed temporary fill slopes with a maximum height of approximately 35 feet at inclinations of 2:1 (horizontal to vertical) or flatter. The existing site conditions and approximate oversize rock fragments are presented on the Existing Site Plan.



Existing Site Plan

After remedial grading of the surficial soil and installation of toe drains, the western and eastern facing embankment fill slopes were constructed along the margins of a shallow alluvial drainage. At the direction of Terra Development Inc. and HomeFed, the contractor extended the soil-rock fill to the temporary slope face instead of placing finer-grained compacted fill materials for placement on the outer slope face as outlined in our letters dated October 9, 2020, and July 15, 2021. Although the contractor properly placed the soil-rock fill, the slope surface areas of the soil-rock fill possess voids between the rock fragments that will require additional remedial grading during future grading operations. Some oversize rock will require special handling and benching techniques prior to additional fill placement.

5. SUBDRAINS

The grading contractor installed toe drains and a canyon subdrain at the general locations shown on the As-Graded Geologic Map, Figures 1 and 2. In addition, the subdrains were “as-built” for location and elevation by the project civil engineers, Hale Engineering, and Hunsaker & Associates, San Diego, Incorporated. The canyon subdrains and toe drains consists of 6- to 8-inch-diameter, Schedule 40, perforated PVC pipe placed in $\frac{3}{4}$ -inch crushed aggregate gravel surrounded by Mirafi 140N (or equivalent) filter fabric. The perforated pipe is connected to a solid pipe at the end of the drain near the

outlet. The canyon subdrains and toe drains have been outlet into open space as-depicted as the As-Graded Geologic Map. These subdrains should be extended during the proposed mass grading operations for the future development.

6. GEOLOGIC SETTING

The site is located in the coastal plain of the Peninsular Ranges province of southern California. The Peninsular Ranges is a geologic and geomorphic province that extends from the Imperial Valley to the Pacific Ocean and from the Transverse Ranges to the north and into Baja California to the south. The coastal plain of San Diego County is underlain by a thick sequence of relatively undisturbed and non-conformable sedimentary rocks that range in age from Upper Cretaceous through the Pleistocene with intermittent deposition. Geomorphically, the coastal plain is characterized by a stair-stepped series of marine terraces, which are younger to the west and have been dissected by west flowing rivers that drain the Peninsular Ranges to the east. The coastal plain is a relatively stable block that is dissected by relatively few faults consisting of the potentially active La Nacion Fault Zone and the active Rose Canyon Fault Zone. The Peninsular Ranges are also dissected by the Elsinore Fault Zone that is associated with and sub-parallel to the San Andreas Fault Zone, which is the plate boundary between the Pacific and North American Plates.

The site is located on the central portion of the coastal plain. A prominent outcrop composed of Metavolcanic Rock (Mzu) is located west of the site. Marine sedimentary units unconformably overlie the Metavolcanic Rock and consist of a Pleistocene age Terrace Deposits (Qt) and the Tertiary age Otay Formation (To). The Terrace Deposits are shallow marine and non-marine sandstone units with layers containing cobble up to 18 inches in diameter. This unit is located on the southern portion of the site on the northern flanks of the Otay River Valley. Otay Fanglomerate is mapped along the southern flanks of the site; however, we do not expect to encounter it at the site. We expect this unit could be consistent with the gritstone member discussed herein. The Otay Formation typically consists of three lithostratigraphic members composed of a basal conglomerate member, a middle gritstone member and an upper sandstone/siltstone/claystone member with a maximum reported regional thickness of roughly 400 feet. The upper two members of the Otay Formation are present on the site. In addition, bentonitic claystone layers are common within the upper member typically deposited as highly consolidated volcanic ash deposits. The site has been dissected by a series of northwest trending canyons that have exposed the Otay Formation. Pleistocene-age Terrace Deposits are present on the northern flank of the Otay River. A Regional Geologic Map is presented herein.

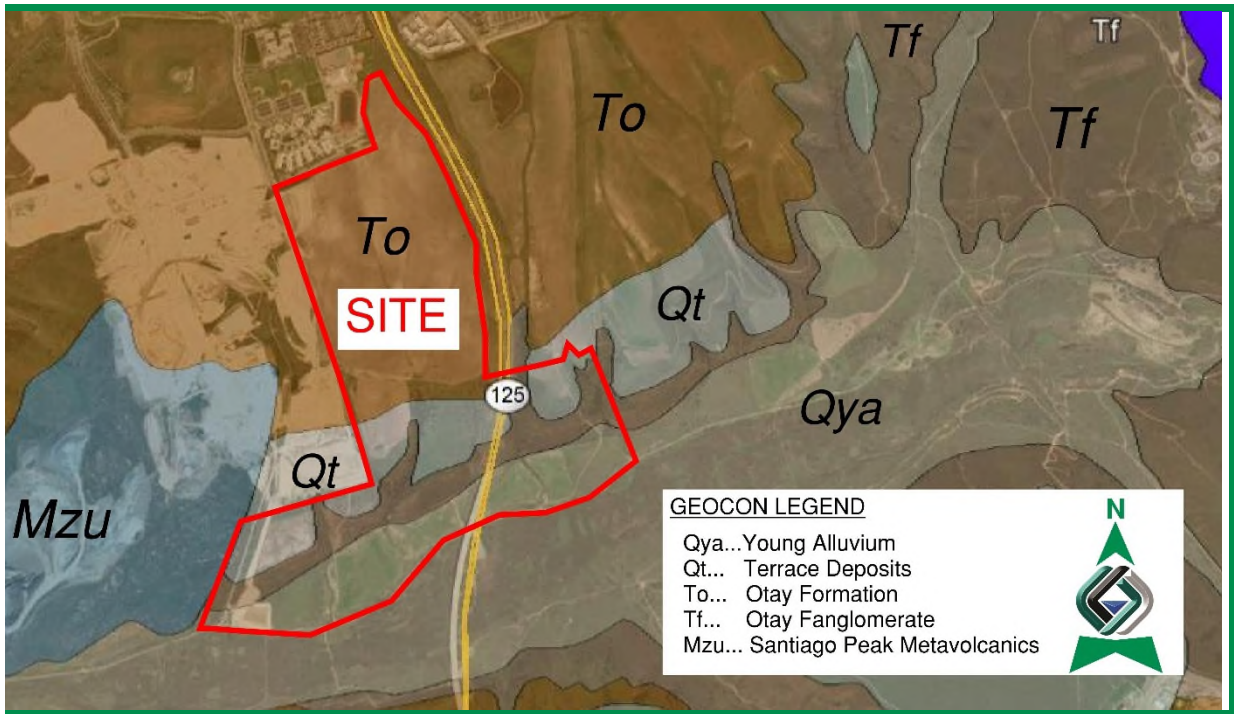

Regional Geologic Map

7. SOIL AND GEOLOGIC CONDITIONS

During our field investigation, disposal and borrow site grading operations, we encountered four surficial deposits (consisting of previously placed fill, undocumented fill, topsoil, and alluvium) and two formational units (consisting of Pleistocene age Terrace Deposits and Tertiary-age Otay Formation). We subdivided the Otay Formation into the upper sandstone/siltstone/claystone member (To) and an underlying middle gritstone member (Tog). We did not encounter the lower basal conglomerate member of the Otay Formation on site. The lateral extent of the materials encountered is shown on the Geologic Map, Figures 1 through 4. Figure 5 presents Geologic Cross-Sections providing an interpretation of the subsurface geologic conditions. We prepared the geologic cross-sections using interpolation between exploratory excavations and observations; therefore, actual geotechnical conditions may vary from those illustrated and should be considered approximate. The descriptions of the soil and geologic conditions are shown on the boring logs located in Appendix A, the laboratory testing in Appendix B, and described herein in order of increasing age.

7.1 Previously Placed Fill (Qpf)

Previous grading has occurred along the northern portion of the site during the construction of Main Street and the adjacent high school consisting of the placement of previously placed fill. The previous grading was completed in 2005 with the testing and observation services provided by Geotechnics Incorporated (see *List of References*). The grading consisted of the removal of surficial soil, placement

of two canyon subdrain and two soil-rock fill subdrains, and the placement and compaction of fill soil to achieve finish grades. The two canyon subdrains should be extended up-gradient during mass grading operations to 10 feet below proposed grades. A buttress fill constructed during grading in 2007 possesses a subsurface drain constructed on the ascending slope on the south side of Main Street on the western portion of the roadway (see Geologic Map). During mass-grading for Otay Ranch Village 8 East, performed by AGS, Inc. the 8-inch subdrain has been outlet to an approved structure along Main Street East during the site development within Village 8 East. In general, the fill consists of medium dense to dense, moist, silt and sand. In its present condition, the fill soil is suitable for support of additional fill or utilities; however, the upper portion of the fill soil will require remedial grading.

7.2 Undocumented Fill Soil (Qudf – Environmental Stockpile)

Undocumented fill soil is present as stockpiles on the site adjacent to the disposal and borrow areas. The contractor placed stockpiles during the soil remediation program topsoil material which consists of stripped and stockpiled topsoil and surficial materials. The stockpiled material will be placed during mass-grading operations in accordance with project specifications. The undocumented fill possesses a thickness of at least 10 to 35 feet thick and can be characterized as soft to loose, dry to damp, sandy clay to clayey sand. The undocumented fill is compressible and removal will be necessary within the limits of grading in areas to support proposed fill or structures, or in areas of additional removals and placement of additional compacted.

7.3 Undocumented Fill Soil (Qudf)

Undocumented fill soil is also present on the central portion of the site adjacent to and within the existing City of San Diego Otay 2nd and 3rd pipelines. The fill was likely placed during the excavation of the aqueduct and to traverse the property. The undocumented fill likely has a thickness of at least 10 to 15 feet thick and can be characterized as soft to loose, dry to damp, sandy clay to clayey sand. The undocumented fill is compressible and removal will be necessary within the limits of grading in areas to support proposed fill or structures.

7.4 Compacted Fill (Qcf)

Compacted fill associated with the grading operations exists on the partially graded disposal sites. In general, the fill consists of soil-rock fills generated from the neighboring Otay Ranch Village 8 West. The contractor placed fill materials generated from the excavations within metavolcanic rock areas in Otay Ranch Village 8 East and placed as compacted fill. The outside edge of the temporary fill slopes consists of a rockfill which will require additional remedial during mass grading operations. The compacted fill is considered suitable for support and development of proposed improvements; however, the upper portions, and temporary rock fill areas will require processing and recompaction prior to placing fill or improvements.

7.5 Topsoil (unmapped)

Holocene-age topsoil is present as a relatively thin veneer overlying formational materials across the site. The topsoil has a thickness of approximately 2 to 4 feet and can be characterized as soft to stiff and loose to medium dense, dry to damp, dark brown, sandy clay to clayey sand with gravel and cobble. The topsoil is typically expansive and compressible. Removal of the topsoil will be necessary within the limits of grading in areas to support proposed fill or structures. Due to the relatively thin thickness and discontinuity of these deposits, topsoil is not shown on the Geologic Map.

7.6 Alluvium (Qal)

Holocene-age alluvium is sheet-flow or stream deposited material found within the canyon drainages and the southern river area. The alluvium generally varies in thickness dependent on the size of the canyon and extent of the drainage area. The alluvium within the canyon drainages is loose to medium dense, can become saturated and difficult to excavate during the rainy season. We estimate the thickness of the alluvium to range up to approximately 7 feet within the tributary canyons and 11 feet within the Otay River Drainage on the south side of the site. Due to the relatively unconsolidated nature of these deposits, remedial grading will be necessary in areas to receive proposed fill or structures.

7.7 Terrace Deposits (Qt)

Pleistocene-age Terrace Deposits are deposited as shallow marine and non-marine near shore soil located on the southern portion of the site and the northern flank of the Otay River canyon drainage. We expect this unit may be in excess of 50 feet thick. The Terrace Deposits are generally dense to very dense, reddish brown, silty to clayey sandstone with portions of the unit containing intermittent layers of cobbles and boulders up to about 2 feet in diameter. The Terrace Deposits are suitable for the support of proposed fill and structural loads; however, select grading operations will be required to properly place the cobble and boulders where encountered.

7.8 Otay Formation (To, Tob and Tog)

Tertiary-age Otay Formation is exposed across the site or located below the surficial soil and Terrace Deposits. The upper member of this unit (To) consists of interbeds of dense to very dense, slightly cemented, silty to clayey sandstone and hard, siltstone and claystone layers. In addition, several layers of bentonitic claystone (Tob) with a maximum thickness of approximately 1 foot thick are present within this unit on the northern and middle portions of the site that can create slope instability. Some of the layers are locally discontinuous and range in elevations as high as 573 feet MSL to as low as 416 feet MSL. The approximate locations of the more prominent layers of bentonite are presented on the Geologic Map, Figures 1 through 4. Some minor discontinuous layers of bentonitic claystone are also present with a thickness of 1 to 3 inches. The bentonite did not appear to be sheared or remolded as observed in our previous excavation.

The middle gritstone Otay Formation member (Tog), generally located below an elevation of 370 feet MSL, consists of very dense, slightly to moderately cemented, silty to clayey sandstone with interbeds of gravel and cobble generally with a maximum dimension of about 1 foot. We do not expect to encounter the lower basal conglomerate member of the Otay Formation. Excavations within both the upper and middle members will generally be possible with heavy-duty grading equipment with heavy effort; however, moderately cemented zones will create very difficult ripping and generate oversized cemented cobbles and boulders. The Otay Formation is suitable for the support of proposed fill and structural loads. The gritstone member of this unit is generally stable when excavated to construct cut slopes. However, the siltstone, claystone, and bentonitic claystone layers within the member will require slope stabilization when exposed in cut slopes, near fill slopes, and behind MSE retaining walls.

The Tertiary-age (upper Oligocene) Otay Formation underlies the site on canyon slopes or underlying the younger geologic formations and surficial soil at depth. The Otay Formation consists of dense, silty, fine- to coarse-grained sandstone, clayey and sandy siltstone, and silty claystone with continuous and discontinuous interbeds of highly expansive bentonitic claystone. The coarse-grained portions of the Otay Formation typically possess a “very low” to “low” expansion potential (expansion index of 50 or less) and adequate shear strength. The fine-grained siltstone and claystone portions of the formation can exhibit a “medium” to “very high” expansion potential (expansion index greater than 50). With the exception of the bentonitic claystone, the Otay Formation is suitable for the support of compacted fill and structural loads.

8. GEOLOGIC STRUCTURE

Bedding attitudes observed within formational materials encountered during the investigation are nearly horizontal to slightly dipping toward the southwest. The regional dip of sedimentary units in the eastern Chula Vista area is generally 1 to 5 degrees toward the southwest. The granular portions of the formational units are typically massive with bedding not discernible. Shear zones create a possibility for slope instability and, where encountered during grading, should be evaluated for the necessity of remedial grading. High-angle contacts between formational units are not uncommon; however, it is our opinion that adverse geologic structure does not present a significant geologic hazard to the proposed development of the site if the recommendations of this report are incorporated into design and construction.

9. GROUNDWATER

We did not encounter a static groundwater table in the previous exploratory excavations and during the grading operations. We do not expect groundwater to adversely impact the development of the property. During storm drain excavations we observed minor seepage within formational materials. It is not uncommon for groundwater seepage conditions to develop where none previously existed due to the permeability characteristics of the geologic units encountered on site. During the rainy season, perched

water conditions are likely to develop within the drainage areas that may require special consideration during grading operations. Groundwater elevations are dependent on seasonal precipitation, irrigation, and land use, among other factors, and vary as a result.

10. GEOLOGIC HAZARDS

10.1 Faulting and Seismicity

A review of the referenced geologic materials and our knowledge of the general area indicate that the site is not underlain by active, potentially active, or inactive faults. An active fault is defined by the California Geological Survey (CGS) as a fault showing evidence for activity within the last 11,000 years. The site is not located within a State of California Earthquake Fault Zone.

The USGS has developed a program to evaluate the approximate location of faulting in the area of properties. The following figure shows the location of the existing faulting in the San Diego County and Southern California region. The fault traces are shown as solid, dashed and dotted that represent well-constrained, moderately constrained and inferred, respectively. The fault line colors represent faults with ages less than 150 years (red), 15,000 years (orange), 130,000 years (green), 750,000 years (blue) and 1.6 million years (black).

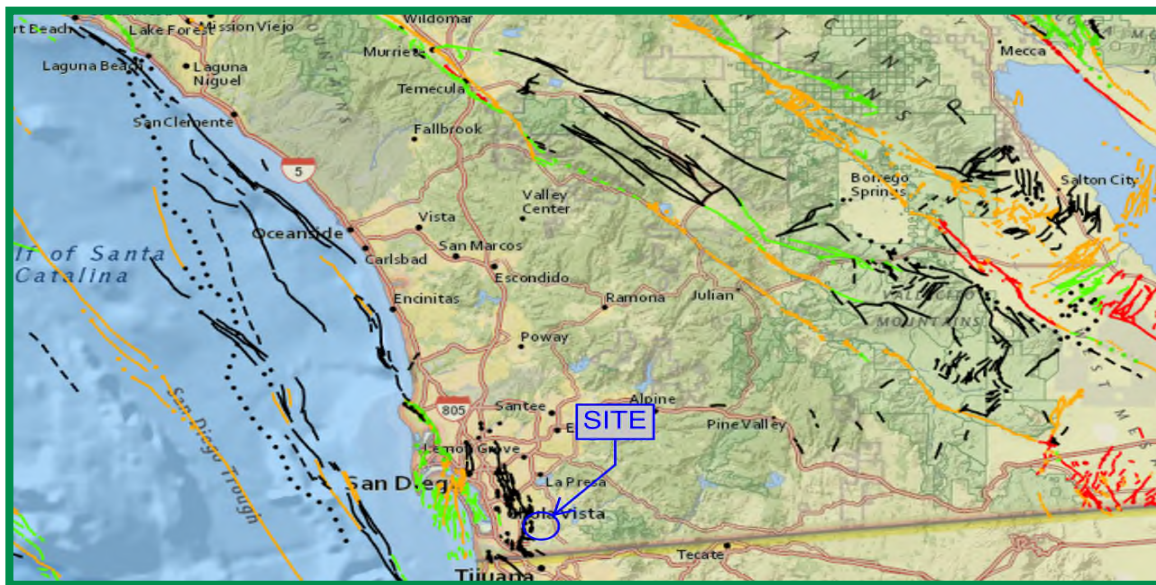

Faults in Southern California

The San Diego County and Southern California region is seismically active. The following figure presents the occurrence of earthquakes with a magnitude greater than 2.5 from the period of 1900 through 2015 according to the Bay Area Earthquake Alliance website.

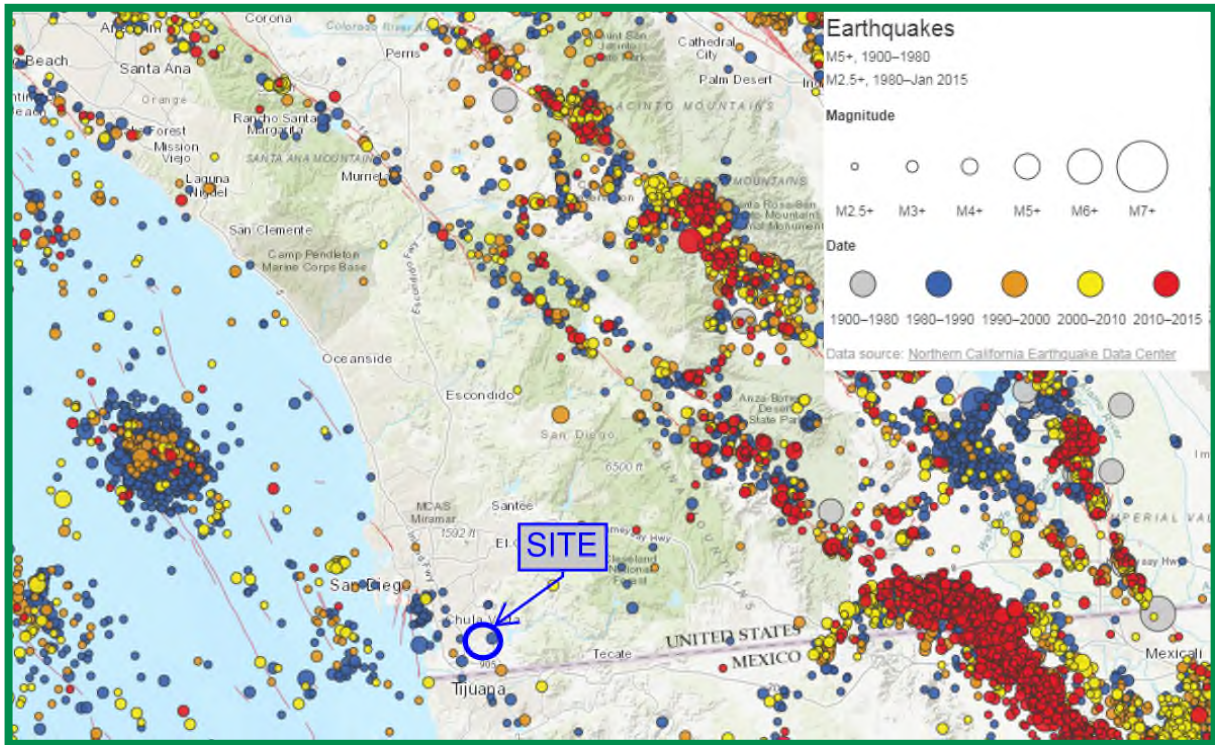

Earthquakes in Southern California

Considerations important in seismic design include the frequency and duration of motion and the soil conditions underlying the site. Seismic design of structures should be evaluated in accordance with the California Building Code (CBC) guidelines currently adopted by the City of Chula Vista.

10.2 Liquefaction

Liquefaction typically occurs when a site is located in a zone with seismic activity, onsite soils are cohesionless or low plasticity silt/clay, static groundwater is encountered within 50 feet of the surface, and soil relative densities are less than about 70 percent. If the four previous criteria are met, a seismic event could result in a rapid pore-water pressure increase from the earthquake-generated ground accelerations. Seismically induced settlement may occur whether the potential for liquefaction exists or not. The potential for liquefaction and seismically induced settlement occurring within the site soil is considered to be very low due to the dense nature of proposed fill and the very dense nature of the formational materials.

10.3 Landsliding

We did not observe evidence of landslide deposits within the proposed development area or adjacent to the property during the geotechnical investigation or during previous grading operations. Therefore, landslides are not considered a potential geologic hazard at the site.

10.4 Seiches and Tsunamis

A tsunami is a series of long period waves generated in the ocean by a sudden displacement of large volumes of water. Causes of tsunamis include underwater earthquakes, volcanic eruptions, or offshore slope failures. The site is approximately 9 miles from the Pacific Coast and finish grades will range between approximately 180 feet and 540 feet above MSL after grading. Therefore, we consider the risk associated with tsunamis to be negligible.

A seiche is a run-up of water within a lake or embayment triggered by fault- or landslide-induced ground displacement. The site is not located near or adjacent to a large body of water. However, the Otay River drainage channel along the south side of the site is located downstream of Lower Otay Lake located approximately 2 miles to the east. The lowest elevation at the site after grading is proposed to be approximately 25 feet above the drainage channel. Therefore, the potential of seiches affecting the site or flooding due to a breach or overtopping of the dam structure is considered very low.

10.5 Slope Stability

We evaluated the maximum proposed cut and fill slope heights and MSE wall configurations, as depicted on the Geologic Map, to evaluate both surficial and global stability based on the current geologic information. The portions of the site planned for grading are generally underlain by Quaternary-age surficial soil, Quaternary-age Terrace Deposits, and Tertiary-age Otay Formation. The unit most likely to be subject to slope instability is the bentonitic claystone layers within the upper member of the Otay Formation encountered on the northern and middle portions of the site. Appendix C presents the slope stability analyses using the two-dimensional computer program *GeoStudio2018* created by Geo-Slope International Ltd. The proposed slopes and MSE retaining walls have calculated factors of safety greater than 1.5 for global and shallow sloughing conditions provided our recommendations for grading and drainage are incorporated into the design and construction of the proposed slopes and MSE retaining walls. We expect extended grid lengths will be required for the planned MSE walls to have an appropriate factor of safety as shown in Appendix C.

In general, we opine permanent, graded fill slopes constructed of granular soil and cut slopes excavated within the middle member of the Otay Formation and Terrace Deposits at the site with gradients of 2:1 (horizontal to vertical) or flatter will possess Factors of Safety of 1.5 or greater. However, stability fills will be required on the cut slopes where the siltstone/claystone members of the Otay Formation are encountered and where loose or cohesionless material is encountered. In addition, a buttress fill will be required during grading operations on the eastern portion of the site (See Geologic Cross-Sections E-E', F-F' and H-H') and next to Otay Valley Road (See Geologic Cross-Section D-D') where bentonite will be encountered in the slope zone during grading operations. The buttresses will require a minimum widths ranging from 15 to 30 feet, as calculated. We will evaluate the length and location of the buttress when the 40-scale grading plans have been prepared. A structural setback would be required behind the

buttness shown on Geologic Cross-Section F-F' to keep the required buttness within the limits of grading. We should review the grading report for SR-125 to check is a buttness was installed adjacent to the roadway.

Grading of cut and fill slopes should be designed in accordance with the requirements of the local building codes of the City of Chula Vista and the 2019 California Building Code (CBC). Mitigation of unstable cut slopes can be achieved by the use of drained stability or buttness fills.

Slopes should be landscaped with drought-tolerant vegetation having variable root depths and requiring minimal landscape irrigation. In addition, slopes should be drained and properly maintained to reduce erosion.

10.6 Erosion

The site is not located adjacent to the Pacific Ocean coast or a free-flowing drainage where active erosion is occurring. Provided the engineering recommendations herein are followed and the project civil engineer prepares the grading plans in accordance with generally-accepted regional standards, we do not expect erosion to be a major impact to site development. In addition, we expect the proposed development would not increase the potential for erosion if properly designed.

11. CONCLUSIONS AND RECOMMENDATIONS

11.1 General

- 11.1.1 From a geotechnical engineering standpoint, we opine the site is suitable for development provided the recommendations presented herein are implemented in design and construction of the project.
- 11.1.2 Based on observations and test results, we opine the grading to which this report pertains has been performed in conformance with the recommendations of the previously referenced project soils report prepared by Geocon Incorporated, dated March 14, 2014, our letters dated October 9, 2020 and July 15, 2021, and the geotechnical requirements of the grading plans.
- 11.1.3 We did not observe soil or geologic conditions during grading that would preclude the continued development of the property as planned. Based on laboratory test results and field observations, the fill observed and tested as part of the grading for this project was generally compacted to a dry density of at least 90 percent of the laboratory maximum dry density near to slightly above optimum moisture content.
- 11.1.4 The site is underlain by compacted fill overlying the Otay Formation. We observed the placement of compacted fill during the mass grading operations and performed in-place density tests to evaluate the dry density and moisture content of the fill material.
- 11.1.5 We opine soil within fill areas with residual pesticides was stockpiled during disposal site grading operations. Topsoil was not placed as compacted fill.
- 11.1.6 Potential geologic hazards at the site include seismic shaking, and low to highly plastic claystone layers, expansive and compressible soil. Based on our investigation, observations during previous grading operations, and available geologic information, active, potentially active, or inactive faults are not present underlying or trending toward the site.
- 11.1.7 The existing surficial soil units including undocumented fill associated with previous grading and the backfill operations of the existing Otay 2nd and 3rd pipeline, topsoil and alluvium are potentially compressible and unsuitable in their present condition for the support of compacted fill or settlement-sensitive improvements. Remedial grading of the surficial soil will be required and recommendations for remedial grading are provided herein. The compacted fill, previously placed fill, Terrace Deposits and Otay Formation are suitable for the support of proposed fill and structural loads.

- 11.1.8 We did not encounter groundwater during our subsurface exploration and we do not expect it to be a constraint to project development. However, seepage within near surface formational materials and perched groundwater conditions within the canyon drainages may be encountered during the grading operations, especially during the rainy seasons. The installation of canyon subdrains and drained buttress and stability fills will be required to be constructed during grading operations.
- 11.1.9 The rippability of the surficial units is expected to range from easy to moderate. We expect the Terrace Deposits and Otay Formation to be rippable with heavy to very heavy effort to proposed finish grades. Cobbles/boulders and cemented zones should be expected within portions of Terrace Deposits. Cemented zones should be expected within portions of the gritstone member of the Otay Formation and Terrace Deposits that will require extra ripping effort using D-10 bulldozers to excavate. Oversize material will likely be generated during ripping operations within the Otay Formation and special grading techniques will be required.
- 11.1.10 In general, cut slopes composed of the middle member of the Otay Formation (Tog) and Terrace Deposits (Qt) should possess a Factors of Safety at least 1.5 at inclinations of 2:1 (horizontal to vertical), or flatter. However, construction of a buttress fill will be required where bentonite is exposed at or near the slope face such as on the eastern portion of the site. Geologic Cross-Section F-F' requires a buttress width of at least 30 feet to provide a minimum factor of safety of 1.5. Construction of stability fills for proposed cut slopes within the upper sandstone/siltstone/claystone member of the Otay Formation (To) on the northern and middle portions of the site.
- 11.1.11 Proper drainage should be maintained in order to preserve the engineering properties of the fill in the sheet-graded pad and slope areas. Recommendations for site drainage are provided herein.
- 11.1.12 The site is considered suitable for the use of conventional continuous and spread footings with a concrete slab-on-grade system or a post-tensioned foundation system.

11.2 Existing Grade Soil Conditions

- 11.2.1 The soil encountered in the field investigation is considered to be “expansive” (expansion index [EI] greater than 20) as defined by 2022 California Building Code (CBC) Section 1803.5.3. Additional expansion index testing should be performed subsequent to the grading operations to evaluate the expansion potential of the upper 3 to 4 feet of soil within the areas of proposed structures and improvements. Table 11.2 presents soil classifications based on the expansion index.

**TABLE 11.2
EXPANSION CLASSIFICATION BASED ON EXPANSION INDEX**

Expansion Index (EI)	Expansion Classification	2022 CBC Expansion Classification
0 – 20	Very Low	Non-Expansive
21 – 50	Low	Expansive
51 – 90	Medium	
91 – 130	High	
Greater Than 130	Very High	

11.2.2 Based on laboratory tests performed during our field investigation, the EI of the surficial soil, Terrace Deposits and the Otay Formation is variable. We expect the surficial soils will possess a “medium” to “high” expansion potential (EI of 51 to 130). The bentonitic claystone and siltstone layers within the upper sandstone/siltstone/claystone member of the Otay Formation may possess a “very high” expansion potential (EI greater than 130). The sandstone layers within the upper and middle members of the Otay Formation will likely possess a “very low” to “low” expansion potential (EI of 50 or less). The siltstone and claystone layers within the upper member of the Otay Formation will likely possess a “medium” to “high” expansion potential (EI of 51 to 130). Due to the range of expansion potential typically exhibited by the Otay Formation, the expansion potential should be evaluated for the building pads once final grade is achieved. The undercutting of cut lots within the Otay Formations should also be performed.

11.2.3 Based on review of the referenced geotechnical reports, laboratory tests on samples of the site materials to evaluate the percentage of water-soluble sulfate content indicate the on-site materials at the locations tested possess “S0” sulfate exposure to concrete structures as defined by 2022 CBC Section 1904 and ACI 318-14 Chapter 19. Table 9.2 presents a summary of concrete requirements set forth by 2019 CBC Section 1904 and ACI 318. The presence of water-soluble sulfates is not a visually discernible characteristic; therefore, other soil samples from the site could yield different concentrations. Additionally, over time landscaping activities (i.e., addition of fertilizers and other soil nutrients) may affect the concentration.

11.2.4 Geocon Incorporated does not practice in the field of corrosion engineering. Therefore, further evaluation by a corrosion engineer may be performed if improvements that could be susceptible to corrosion are planned.

11.3 Seismic Design Criteria – 2022 California Building Code

11.3.1 Table 11.3.1 summarizes site-specific design obtained from the 2022 California Building Code (CBC; Based on the 2021 International Building Code [IBC] and ASCE 7-16), Chapter

16 Structural Design, Section 1613 Earthquake Loads. We used the computer program *U.S. Seismic Design Maps*, provided by the Structural Engineers Association (SEA) to calculate the seismic design parameters. The short spectral response uses a period of 0.2 second. The structures should be designed using Site Class C where there is less than 20 feet of fill and Site Class D where the fill thickness is 20 feet or greater. We evaluated the Site Class based on the discussion in Section 1613.2.2 of the 2022 CBC and Table 20.3-1 of ASCE 7-16. The values presented herein are for the risk-targeted maximum considered earthquake (MCE_R). Sites designated as Site Class D, E and F may require additional analyses if requested by the project structural engineer and client.

**TABLE 11.3.1
2019 CBC SEISMIC DESIGN PARAMETERS**

Parameter	Value		2022 CBC Reference
Site Class	C	D	Section 1613.2.2
Fill Thickness, T (feet)	$T < 20$	$T \geq 20$	--
MCE_R Ground Motion Spectral Response Acceleration – Class B (short), \bar{S}_S	0.745g	0.745g	Figure 1613.2.1(1)
MCE_R Ground Motion Spectral Response Acceleration – Class B (1 sec), S_1	0.272g	0.272g	Figure 1613.2.1(2)
Site Coefficient, F_A	1.202	1.202	Table 1613.2.3(1)
Site Coefficient, F_V	1.5	1.5*	Table 1613.2.3(2)
Site Class Modified MCE_R Spectral Response Acceleration (short), S_{MS}	0.895g	0.897g	Section 1613.2.3 (Eqn 16-20)
Site Class Modified MCE_R Spectral Response Acceleration – (1 sec), S_{M1}	0.409g	0.560g*	Section 1613.2.3 (Eqn 16-21)
5% Damped Design Spectral Response Acceleration (short), S_{DS}	0.597g	0.598g	Section 1613.2.4 (Eqn 16-22)
5% Damped Design Spectral Response Acceleration (1 sec), S_{D1}	0.272g	0.373g*	Section 1613.2.4 (Eqn 16-23)

*See following paragraph.

- 11.3.2 Using the code-based values presented in this Table 7.3.1, in lieu of a performing a ground motion hazard analysis, requires the exceptions outlined in ASCE 7-16 Section 11.4.8 be followed by the project structural engineer. Per Section 11.4.8 of ASCE/SEI 7-16, a ground motion hazard analysis should be performed for projects for Site Class “D” sites with S_1 greater than 0.2g. Section 11.4.8 also provides exceptions which indicates that the ground motion hazard analysis may be waived provided the exceptions are followed. Supplement 3 of ASCE 7-16 provides an exception stating that that the GMHA may be waived provided that the parameter S_{M1} is increased by 50% for all applications of S_{M1} . The values for parameters S_{M1} and S_{D1} presented herein above have **not** been increased in accordance with Supplement 3 of ASCE 7-16.

11.3.3 Table 11.3.2 presents the mapped maximum considered geometric mean (MCE_G) seismic design parameters for projects located in Seismic Design Categories of D through F in accordance with ASCE 7-16.

**TABLE 11.3.2
2022 CBC SITE ACCELERATION DESIGN PARAMETERS**

Parameter	Value		ASCE 7-16
	C	D	
Site Class	C	D	--
Fill Thickness, T (Feet)	$T \leq 20$	$T > 20$	--
Mapped MCE_G Peak Ground Acceleration, PGA	0.323g	0.323g	Figure 22-7
Site Coefficient, F_{PGA}	1.2	1.277	Table 11.8-1
Site Class Modified MCE_G Peak Ground Acceleration, PGA_M	0.388g	0.413g	Section 11.8.3 (Eqn 11.8-1)

11.3.4 Conformance to the criteria in Tables 11.3.1 and 11.3.2 for seismic design does not constitute any kind of guarantee or assurance that significant structural damage or ground failure will not occur in the event of a large earthquake. The primary goal of seismic design is to protect life, not to avoid all damage, since such design may be economically prohibitive.

11.3.5 The project structural engineer and architect should evaluate the appropriate Risk Category and Seismic Design Category for the planned structures. The values presented herein assume a Risk Category of II and resulting in a Seismic Design Category D. Table 11.3.3 presents a summary of the risk categories in accordance with ASCE 7-16.

**TABLE 11.3.3
ASCE 7-16 RISK CATEGORIES**

Risk Category	Building Use	Examples
I	Low risk to Human Life at Failure	Barn, Storage Shelter
II	Nominal Risk to Human Life at Failure (Buildings Not Designated as I, III or IV)	Residential, Commercial and Industrial Buildings
III	Substantial Risk to Human Life at Failure	Theaters, Lecture Halls, Dining Halls, Schools, Prisons, Small Healthcare Facilities, Infrastructure Plants, Storage for Explosives/Toxins
IV	Essential Facilities	Hazardous Material Facilities, Hospitals, Fire and Rescue, Emergency Shelters, Police Stations, Power Stations, Aviation Control Facilities, National Defense, Water Storage

11.4 Slope Stability Analyses

- 11.4.1 We performed slope stability analyses using the computer software program *GeoStudio 2018* to calculate the factor of safety with respect to deep-seated instability. This program uses conventional slope stability equations and a two-dimensional, limit-equilibrium method. We performed the rotational-mode and block-mode analyses using Spencer's method. Output of the computer program including the calculated Factor of Safety and the failure surface is shown in Appendix A.
- 11.4.2 We used average drained direct shear strength parameters based on laboratory tests and our experience with similar soil types in nearby areas. Our slope stability calculations indicate the proposed cut and fill slopes, constructed of onsite materials, should have calculated factors of safety of at least 1.5 under static conditions for both deep-seated failure and shallow sloughing conditions if the recommendations of this report are followed. The shear strength parameters used in the slope stability analyses are presented in Appendix A.
- 11.4.3 Based on the referenced grading plans, several MSE walls are planned on the property. Some walls have heights of about 25 feet. Based on our experience, additional grid reinforcement may be required for the walls to possess a factor of safety of at least 1.5. We should perform global stability analyses of the walls prior to submittal of the retaining wall plans for the planned development to evaluate required grid lengths.
- 11.4.4 We selected Geologic Cross-Sections A-A' through H-H' to perform the slope stability analyses. The results and the computer output of the analyses are presented in Appendix A. Table A-II provides a description of the cross-sections, their corresponding factor of safety, and the condition of the slope stability analyses. A factor of safety of 1.5 for static conditions is currently required by the City of Chula Vista for permanent graded slopes.
- 11.4.5 The placement of properly compacted fill will be required to stabilize weak bentonitic claystone and siltstone layers expected to be encountered behind the proposed MSE retaining wall on the east side of the property. In addition, a buttress fill will be required during grading operations on the eastern portion of the site (See Geologic Cross-Sections E-E', F-F' and H-H') and next to Otay Valley Road (See Geologic Cross-Section D-D') where bentonite will be encountered in the slope zone during grading operations. The buttresses will require minimum widths ranging from 15 to 30 feet, as calculated. We will evaluate the length and location of the buttress when the 40-scale grading plans have been prepared. A structural setback would be required behind the buttress shown on Geologic Cross-Section F-F', to keep the required buttress within the limits of grading if the buttress was not installed during the construction for the adjacent roadway.

- 11.4.6 Cut slopes within the upper member of the Otay Formation will require the construction of stability fills to stabilize the slope face as discussed herein.
- 11.4.7 We performed surficial slope stability calculations for the planned slopes. The calculated factor of safety is greater than the required minimum factor of safety of 1.5. Plants with variable root depth should be planted as soon as practical once the fill slopes have been constructed. Table 11.4 presents the surficial slope stability analysis for the proposed sloping conditions. We assumed strengths for topsoil exposed at the slope surface.

**TABLE 11.4
SURFICIAL SLOPE STABILITY EVALUATION**

Parameter	Value
Slope Height, H	∞
Vertical Depth of Saturation, Z	3 Feet
Slope Inclination, I (Horizontal to Vertical)	2:1 (26.6 Degrees)
Total Soil Unit Weight, γ	125 pcf
Water Unit Weight, γ_w	62.4 pcf
Friction Angle, ϕ	28 Degrees
Cohesion, C	250 psf
Factor of Safety = $(C+(\gamma+\gamma_w)Z\cos^2I \tan\phi)/(\gamma Z\sin I \cos I)$	2.2

- 11.4.8 Buttress and stability fill drains should be surveyed for location and elevation during construction and depicted on the As-Graded Geologic Map in the final report of grading.
- 11.4.9 Excavations including cut slopes, shear keys and buttress and stability fills should be observed during grading by an engineering geologist to evaluate whether soil and geologic conditions do not differ significantly from those expected.

11.5 Grading

- 11.5.1 Grading should be performed in accordance with the attached *Recommended Grading Specifications* contained in Appendix B and the City of Chula Vista Ordinance. Where the recommendations of this section conflict with those of Appendix B, the recommendations of this section shall take precedence. Earthwork should be observed and fill tested for dry density and moisture content by Geocon Incorporated.
- 11.5.2 Prior to commencing grading, a preconstruction conference should be held at the site with the city inspector, owner or developer, grading contractor, civil engineer, and geotechnical

engineer in attendance. Special soil handling and/or the grading plans can be discussed at that time.

- 11.5.3 Site preparation should begin with the removal of deleterious material, debris and vegetation. The depth of removal should be such that material exposed in cut areas or soil to be used as fill is relatively free of organic matter. Material generated during stripping and/or site demolition should be exported from the site.
- 11.5.4 Undocumented fill, topsoil and alluvium within the limits of grading should be removed to expose firm Otay Formation or Terrace Deposits. The actual depth of removal should be evaluated by the engineering geologist during grading operations. We do not expect that removals will need to extend beyond the limits of grading. The bottom of the excavations should be scarified to a depth of at least 1 foot, moisture conditioned as necessary, and properly compacted. The upper 2 to 3 feet of previously placed fill will also require remedial grading in the form of removal and recompaction. The remedial grading will be limited to the area of proposed development and should not extend into the MSCP Preserve.
- 11.5.5 Bentonitic claystone layers that occur within 5 feet of finish grade should be removed and replaced with properly compacted fill that possesses a “very low” to “medium” expansion potential (EI of 90 or less). The undercut within the building pads should be sloped at least 2 percent toward the adjacent street or deep fill area.
- 11.5.6 Where bentonite claystone is encountered during grading operations, a buttress/stability fill will be required. In addition, bentonite located within 5 feet of the planned finish grade elevation should be removed and replaced with properly compacted fill. Bentonitic claystone layers encountered during the normal excavation or undercutting of building pads, streets, or slopes should be mixed with granular materials in a ratio of at least two parts sand to one part bentonite clay and compacted to a dry density of at least 90 percent of the laboratory maximum dry density at or slightly above optimum moisture. The mixed bentonite clay should be placed at least 5 feet below finish grade, at least 15 feet from the face of a fill slope, and not within buttress or stability fill slopes.
- 11.5.7 The upper 3 feet of cut lots should be over excavated and replaced with properly compacted fill due to the very dense and cemented nature of the two members of the Otay Formation. The bottom of the excavation should be sloped at least one percent toward the adjacent deeper fill areas or adjacent roadways to reduce the potential for subsurface water to saturate fill materials.

- 11.5.8 The City of Chula Vista has required that the upper 5 feet of fill soil and the upper 3 feet of formational materials within the public right-of-way or public easement possess an expansion index of 90 or less. If material with an expansion index greater than 90 exists within the right-of-ways, the upper 5 feet of compacted fills and the upper 3 feet of formational should be removed and replaced with fill with an expansion index of 90 or less or an alternative method should be approved by the City of Chula Vista.
- 11.5.9 The undocumented fill existing within City of San Diego Otay 2nd and 3rd pipe should be removed and replaced to competent formational materials within the existing easement to design grades. The grading contractor should be careful not to damage the existing water lines if they are left in place and operations during the grading operations. We expect the grading would be limited to about 5 feet above the pipes and about 5 to 10 feet laterally from the pipes. The contractor should provide the proper equipment and evaluation on excavations adjacent to the pipelines. We can provide supplemental recommendations operations during the mass grading operations as necessary.
- 11.5.10 If perched groundwater or saturated materials are encountered during remedial grading, extensive drying and mixing with dryer soil will be required. This condition may potentially occur within the canyon drainages, especially during the rainy season. The excavated materials should then be moisture conditioned as necessary to near optimum moisture content prior to placement as compacted fill.
- 11.5.11 We should observe the grading operations and the removal bottoms to check the exposure of the formational materials prior to the placement of compacted fill. Deeper excavations may be required if highly weathered formational materials are present at the base of the removals. Fill soil should not be placed until we observe the bottom excavations. Table 11.5 provides a summary of the grading recommendations.

**TABLE 11.5.1
SUMMARY OF GRADING RECOMMENDATIONS**

Area	Removal Requirements
Undocumented Fill, Topsoil and Weathered Formational Materials	Remove to Underlying, Dense Formational Materials
Formation Within 3 Feet of Proposed Building Pad Elevations	Undercut 3 Feet Below Finish Grade
Bentonite Within 5 Feet of Proposed Grade	Undercut 3 to 5 Feet Below Finish Grade of Pad or Garages, whichever is Lower
Formation at Grade in Areas of Surface Improvements	Process Upper 1 to 2 Feet of Existing Materials
Lateral Grading Limits	10 Feet Outside of Buildings/2 Feet Outside of Improvement Areas, Where Possible
Exposed Bottoms of Remedial Grading	Scarify Upper 12 Inches

- 11.5.12 The site should be brought to finish grade elevations with fill compacted in layers. Layers of fill should be no thicker than will allow for adequate bonding and compaction. Fill, including backfill and scarified ground surfaces, should be compacted to a dry density of at least 90 percent of the laboratory maximum dry density near to slightly above optimum moisture content in accordance with ASTM D 1557. Fill placed in excess of 40 feet from finish grade should be compacted to a dry density of at least 92 percent of the laboratory maximum dry density near to slightly above optimum moisture content. Fill materials placed below optimum moisture content may require additional moisture conditioning prior to placing additional fill.
- 11.5.13 Topsoil should be handled in accordance with the soil remediation plan. Topsoil can be placed at a depth of greater than 5 from subdrains and at least 10 feet from finish grades.
- 11.5.14 If additional rock fills are planned, in general, structural fill placed and compacted at the site should consist of material that can be classified into four zones discussed in Table 11.5.2.

**TABLE 11.5.2
ROCK FILL ZONES**

Fill Zone	Description
A	Material placed within 3 feet from building pad grade, 8 feet from roadway grade, and to at least 2 feet below the deepest utility within roadways should consist of “soil” fill with an approximate maximum particle dimension of 6 inches with a minimum of 40 percent of the soil passing the ¾-inch sieve. In addition, the upper 3 feet of pad grade should have at least 20 percent of the soil passing the No. 4 sieve.
B	Material placed below 8 feet from grade (below Zone A and C) may consist of “rock” fill or “soil/rock” fill (as defined in Appendix H). Blasted rock should generally consist of 2-foot-minus rock material with occasional rock up to 4 feet in maximum dimension. Alternatively, “soil” fill may be placed in Zone B containing rock with a maximum dimension of 2 feet. Rocks up to 4 feet in maximum dimension can be individually placed in a properly compacted soil matrix with rocks separated at least 8 feet apart.
C	Within 3 to 8 feet of pad grade and between 5 and 15 feet from face of slope, fill material should consist of “soil” fill with an approximate maximum particle dimension of 1 foot. Rocks up to 2 feet in maximum dimension may be placed, provided they are distributed in a matrix of compacted “soil” fill.
D	Within the outer 5 feet of fill slopes, the fill should consist of rock up to 1 foot in maximum dimension in a matrix of compacted “soil” fill.

11.5.15 Recommendations for the handling and disposal of oversized rock in fill areas are presented in the Rock Disposal Detail and in Appendix H.

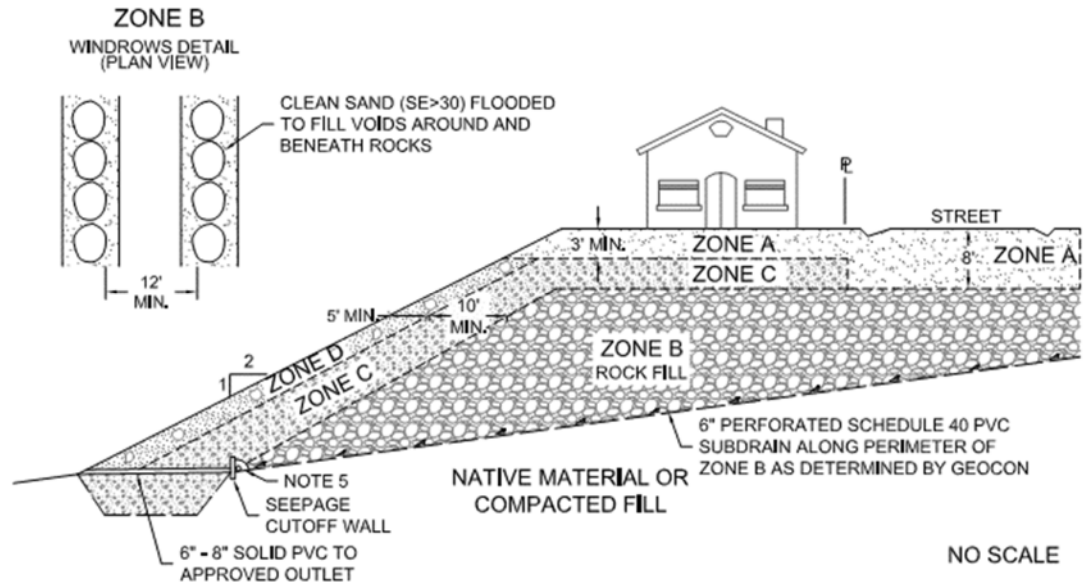

Oversize Rock Disposal Detail

- 11.5.16 Oversize rock placement should be performed in accordance with the Recommended Grading Specifications provided in Appendix B. Blasting of rock material for the proposed sewer should be performed to maximize rock breakage to 2-foot minus material, if necessary. Rock fill placement should generally be limited to 2-foot-thick horizontal layers and compacted using rock trucks and bulldozers. Significant volumes of water are typically required during rock fill placement. The downstream areas can generate large volumes of water that can be re-used during construction.
- 11.5.17 The construction of a buttress fill will be required on the east side of the property that will expose bentonitic claystone or siltstone. Stability fills will be required where the claystone/siltstone portion of the Otay Formation is exposed in the slope faces. Cut slopes located within the upper member of the Otay Formation (To) above an elevation of approximately 370 feet MSL will require the construction of stability fills. The Typical Stability Fill Detail should be used for design and construction of slope buttresses, where required. The backcut for the buttress should commence at least 10 feet from the top of the proposed finish-graded slope and should extend at least 3 feet below adjacent pad grade or below the bentonite layer, to a maximum depth of 15 feet below finish-pad grade. The base of the key should be slopes at least 5 percent to the drain, into slope.

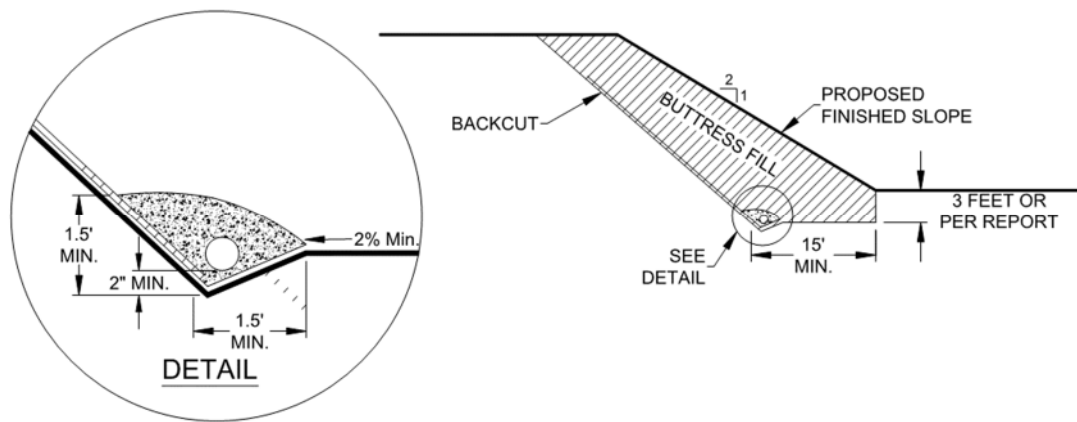

Typical Stability Fill Detail

- 11.5.18 The slope backcut should be a 1:1 and in accordance with OSHA requirements. Chimney drains should be installed along the backcut that are 4 feet wide, 20-foot on center and provide dual-sided drainage. Closer spacing may be required where seepage is encountered. The collector pipe at the base of the backcut should consist of a minimum 4-inch diameter, perforated, Schedule 40 PVC pipe drained at a minimum of 1 percent. The pipe should be surrounded by ¾-inch gravel wrapped in an approved filter fabric (Mirafi 140N or equivalent).

- 11.5.19 Cut slope excavations including buttresses and shear keys should be observed during grading operations to check that soil and geologic conditions do not differ significantly from those expected. During the construction of buttresses, there is a risk that the temporary backcut slopes will becoming unstable if the timing between placement of drains and compacted fill is not achieved. This risk can be reduced by grading the buttress fill in short segments, reducing the timing of leaving a temporary condition, and/or flattening the inclination of the temporary slope.
- 11.5.20 The outer 15 feet (or a distance equal to the height of the slope, whichever is less) of fill slopes should be composed of properly compacted granular “soil” fill to reduce the potential for surficial sloughing. In general, soil with an expansion index of 90 or less and at least 35 percent sand-size particles should be acceptable as “soil” fill. Soil of questionable strength to satisfy surficial stability should be tested in the laboratory for acceptable drained shear strength. The use of cohesionless soil in the outer portion of fill slopes should be avoided. Fill slopes should be overbuilt at least 2 feet and cut back or be compacted by backrolling with a loaded sheepsfoot roller at vertical intervals not to exceed 4 feet to maintain the moisture content of the fill. The slopes should be track-walked at the completion of each slope such that the fill is properly compacted to the face of the finished slope.
- 11.5.21 Finished slopes should be landscaped with drought-tolerant vegetation having variable root depths and requiring minimal landscape irrigation. In addition, the slopes should be drained and properly maintained to reduce erosion.
- 11.5.22 Import fill (if necessary) should consist of the characteristics presented in Table 11.5.3. Geocon Incorporated should be notified of the import soil source and should perform laboratory testing of import soil prior to its arrival at the site to determine its suitability as fill material.

**TABLE 11.5.3
SUMMARY OF IMPORT FILL RECOMMENDATIONS**

Soil Characteristic	Values
Expansion Potential	“Very Low” to “Medium” (Expansion Index of 90 or less)
Particle Size	Maximum Dimension Less Than 3 Inches
	Generally Free of Debris

11.6 Earthwork Grading Factors

11.6.1 Estimates of bulking and shrinkage factors are based on empirical judgments comparing the material in its natural state as encountered in the exploratory excavations to a compacted state. Variations in natural soil density and in compacted fill density render shrinkage value estimates very approximate. As an example, the contractor can compact the fill to a dry density of 90 percent or higher of the laboratory maximum dry density. Thus, the contractor has an approximately 10 percent range of control over the fill volume. Bulking of rock units is a function of rock density, structure, overburden pressure, and the physical behavior of blasted material. Based on our experience, the shrinkage and bulking factors presented in Table 11.6 can be used as a basis for estimating how much the onsite soil may shrink or swell (bulk) when excavated from their natural state and placed as compacted fill. Please note that these estimates are for preliminary quantity estimates only. Due to the variations in the actual shrinkage/bulking factors, a balance area that can also accommodate rock should be provided to accommodate these variations.

**TABLE 11.6
SHRINKAGE AND BULK FACTORS**

Soil Unit	Shrink/Bulk Factor
Surficial Soils (Qudf, topsoil, and Qal)	10% to 15% Shrink
Compacted and Previously Placed Fill (Qpf)	2% Shrink to 2% Bulk
Terrace Deposits	3% to 5% Bulk
Otay Formation (To and Tog)	4% to 8% Bulk

11.7 Subdrains

11.7.1 Conditions encountered prior to and during grading do not necessarily reveal the conditions that will be encountered once construction of the proposed homes is completed. Specifically, irrigation in up gradient areas cannot be reasonably predicted. Therefore, the design and implementation of additional drainage mechanisms may be necessitated. The geologic units encountered on the site have permeability characteristics and/or fracture systems that could be susceptible under certain conditions to groundwater/seepage. The use of canyon subdrains will be necessary to mitigate the potential for adverse impacts associated with seepage conditions. The existing subdrain located at the toe of the fill slope along Rock Mountain Road has been temporarily tied into an approved storm drain structure on Main Street East in Village 8 West and will be removed during future grading operations. The following figure presents a typical canyon subdrain detail.

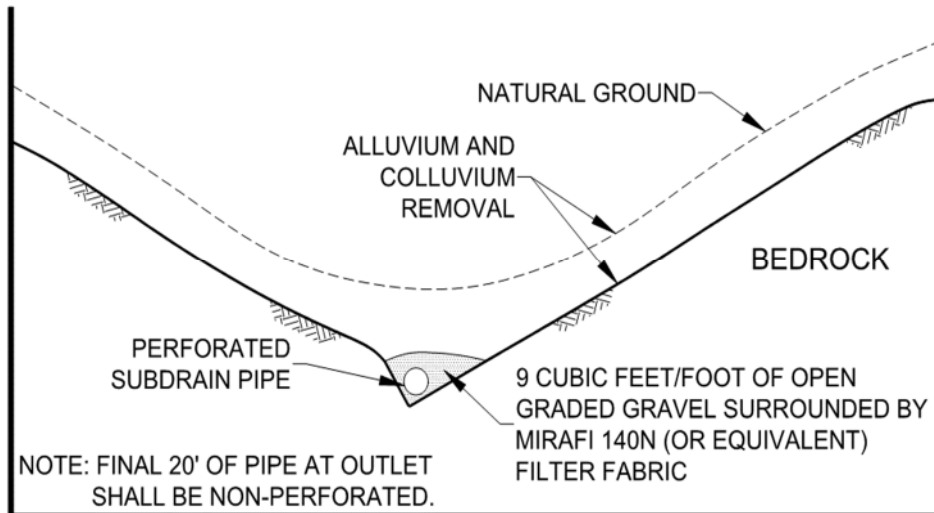

Typical Canyon Subdrain Detail

11.7.2 Stability fill, buttress fill, and canyon subdrains should possess the dimensions presented in Table 11.7. The Geologic Map, Figures 1 through 4 present the locations of proposed canyon subdrains. The actual subdrain locations should be evaluated in the field during the mass grading operations. The project civil engineer should survey the pipe locations and elevations after installation. Appropriate subdrain outlets should be evaluated prior to finalizing 40-scale grading plan.

**TABLE 11.7
RECOMMENDED SUBDRAIN DIMENSIONS**

Drain Size	Drain Recommendations
4-Inch	Schedule 40 PVC or Equivalent
	Stability and Buttress Drains
6-Inch	Schedule 40 PVC (or Equivalent)
	Less Than 100 Feet Deep
	Less Than 500 Feet Long
8-Inch	Schedule 80 PVC (or Equivalent)
	Greater Than 100 Feet Deep
	Greater Than 500 Feet Long

11.7.3 Prior to outletting, the final 20-foot segment of a subdrain that will not be extended during future development should consist of non-perforated drainpipe. At the non-perforated/perforated interface, a seepage cutoff wall should be constructed on the downslope side of the junction as shown herein.

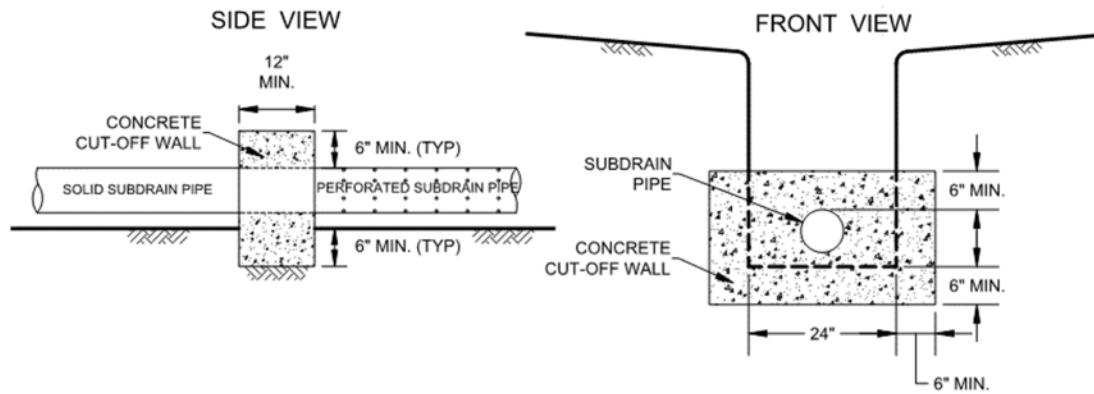

Typical Cutoff Wall Detail

11.7.4 Subdrains that discharge into a natural drainage course or open space area should be provided with a permanent headwall structure as shown herein.

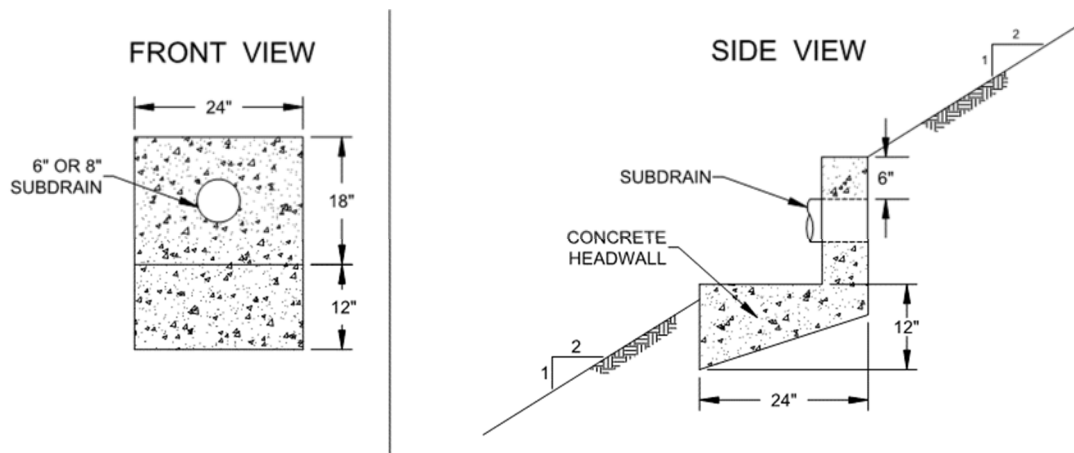

Typical Headwall Detail

11.7.5 Building pad areas adjacent to large ascending slopes may experience wet to saturated soil conditions due to water migration or seepage. To reduce the potential for this to occur, consideration should be given to placing a subdrain along the base of the slopes to collect potential seepage and convey it to a suitable outlet. The pad subdrain should be sufficiently deep to intercept the seepage (on the order of 3 feet below finish grade) and constructed in accordance with the recommendations in the subdrain section of this report. The necessity for the drains should be discussed prior to grading on a slope specific basis. In addition, the project civil engineer should be consulted to evaluate the appropriate drain locations and necessary easements, building restriction zones or disclosure requirements that may be necessary. The pad subdrains should be surveyed for location and shown on the project as-built drawings.

11.7.6 The final grading plans should show the location of the proposed subdrains. Upon completion of remedial excavations and subdrain installation, the project civil engineer should survey the drain locations and prepare an “as-built” map depicting the existing conditions. The final outlet and connection locations should be determined during grading. Subdrains that will be extended on adjacent projects shortly after grading can be placed on formational material and a vertical riser should be placed at the end of the subdrain. The grading contractor should consider videoing the subdrains shortly after burial to check proper installation and to check that the pipe has not been crushed. The contractor is responsible for the performance of the drains.

11.8 Preliminary Foundation and Concrete Slabs-On-Grade Recommendations

11.8.1 The foundation recommendations herein are for the proposed residential structures. The foundation recommendations have been separated into three categories based on the maximum and differential fill thickness and expansion index. Table 11.8.1 presents the foundation category criteria. Based on review of the laboratory test results performed during previous grading, we expect majority of the soil encountered on site is planned to possess a “very low” to “medium” expansion potential (expansion index of 90 or less). Recommended foundation categories for the subject building pads will be provided after fine grading is completed and we re-evaluate the expansion index of the fill material in the upper 3 to 4 feet during the regrading operations.

**TABLE 11.8.1
FOUNDATION CATEGORY CRITERIA**

Foundation Category	Maximum Fill Thickness, T (Feet)	Differential Fill Thickness, D (Feet)	Expansion Index (EI)
I	$T < 20$	--	$EI \leq 50$
II	$20 \leq T < 50$	$10 \leq D < 20$	$50 < EI \leq 90$
III	$T \geq 50$	$D \geq 20$	$90 < EI \leq 130$

11.8.2 Table 11.8.2 presents minimum foundation and interior concrete slab design criteria for conventional foundation systems. The grading of building pads should be such that the upper 3 feet of finish grade soils should have an expansion index of 90 or less, where possible. However, the recommendations presented herein incorporates finish grade soil with an expansion index of up to 130.

**TABLE 11.8.2
CONVENTIONAL FOUNDATION RECOMMENDATIONS BY CATEGORY**

Foundation Category	Minimum Footing Embedment Depth, D (inches)	Minimum Continuous Footing Reinforcement	Minimum Footing Width (Inches)
I	12	Two No. 4 bars, one top and one bottom	12 – Continuous, W_C 24 – Isolated, W_I
II	18	Four No. 4 bars, two top and two bottom	
III	24	Four No. 5 bars, two top and two bottom	

11.8.3 The embedment depths presented in Table 11.8.2 should be measured from the lowest adjacent pad grade for both interior and exterior footing. The foundations should be embedded in accordance with the recommendations herein and the Wall/Column Footing Dimension Detail. The embedment depths should be measured from the lowest adjacent pad grade for both interior and exterior footings. Footings should be deepened such that the bottom outside edge of the footing is at least 7 feet horizontally from the face of the slope (unless designed with a post-tensioned foundation system as discussed herein).

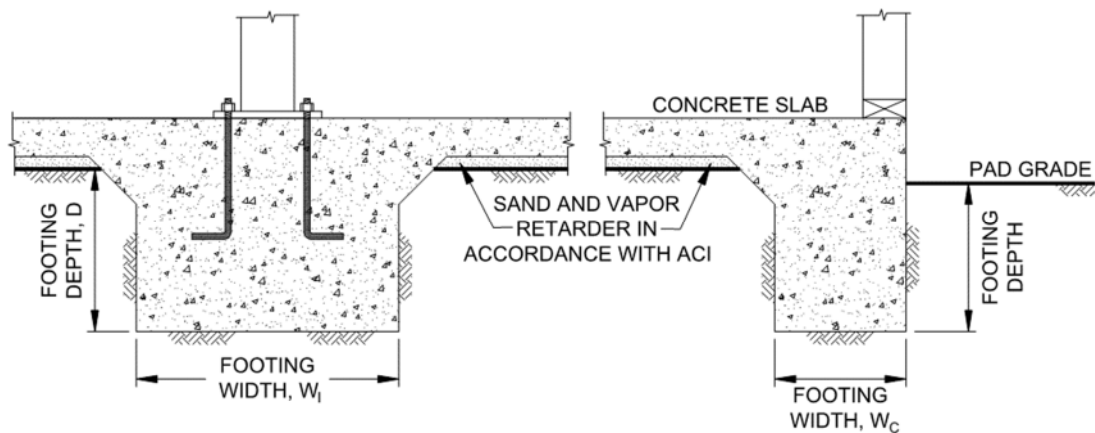

Wall/Column Footing Dimension Detail

11.8.4 We will provide final foundation categories for each building or lot after finish pad grades have been achieved and we perform laboratory testing of the subgrade soil.

11.8.5 Table 11.8.3 presents minimum foundation and interior concrete slab design criteria for conventional foundation systems.

- 11.8.6 The proposed structures can be supported on a shallow foundation system founded in the compacted fill/formational materials. Table 11.8.3 provides a summary of the foundation design recommendations.

**TABLE 11.8.3
SUMMARY OF FOUNDATION RECOMMENDATIONS**

Parameter	Value
Allowable Bearing Capacity	2,000 psf
Estimated Total Settlement	1 Inch
Estimated Differential Settlement	½ Inch in 40 Feet

- 11.8.7 The bearing capacity values presented herein are for dead plus live loads and may be increased by one-third when considering transient loads due to wind or seismic forces.
- 11.8.8 The concrete slab-on-grade should be a minimum of 4 inches thick for Foundation Categories I and II and 5 inches thick for Foundation Category III.
- 11.8.9 Slabs that may receive moisture-sensitive floor coverings or may be used to store moisture-sensitive materials should be underlain by a vapor retarder. The vapor retarder design should be consistent with the guidelines presented in the American Concrete Institute’s (ACI) *Guide for Concrete Slabs that Receive Moisture-Sensitive Flooring Materials* (ACI 302.2R-06). In addition, the membrane should be installed in accordance with manufacturer’s recommendations and ASTM requirements and installed in a manner that prevents puncture. The vapor retarder used should be specified by the project architect or developer based on the type of floor covering that will be installed and if the structure will possess a humidity-controlled environment.
- 11.8.10 The bedding sand thickness should be determined by the project foundation engineer, architect, and/or developer. However, we should be contacted to provide recommendations if the bedding sand is thicker than 6 inches. It is common to see 3 inches and 4 inches of sand below the concrete slab-on-grade for 5-inch and 4-inch thick slabs, respectively, in the southern California area. The foundation design engineer should provide appropriate concrete mix design criteria and curing measures to assure proper curing of the slab by reducing the potential for rapid moisture loss and subsequent cracking and/or slab curl. We suggest that the foundation design engineer present the concrete mix design and proper curing methods on the foundation plans. It is critical that the foundation contractor understands and follows the recommendations presented on the foundation plans.

11.8.11 As an alternative to the conventional foundation recommendations, consideration should be given to the use of post-tensioned concrete slab and foundation systems for the support of the proposed structures. If a post-tensioned system is being used, the proposed buildings would be designated with a Foundation Category once grading is completed. The post-tensioned systems should be designed by a structural engineer experienced in post-tensioned slab design and design criteria of the Post-Tensioning Institute (PTI) DC 10.5-12 *Standard Requirements for Design and Analysis of Shallow Post-Tensioned Concrete Foundations on Expansive Soils* or *WRI/CRSI Design of Slab-on-Ground Foundations*, as required by the 2019 California Building Code (CBC Section 1808.6.2). Although this procedure was developed for expansive soil conditions, it can also be used to reduce the potential for foundation distress due to differential fill settlement. The post-tensioned design should incorporate the geotechnical parameters presented in Table 11.8.4 for the particular Foundation Category designated. The parameters presented in Table 11.8.4 are based on the guidelines presented in the PTI DC 10.5 design manual.

**TABLE 11.8.4
POST-TENSIONED FOUNDATION SYSTEM DESIGN PARAMETERS**

Post-Tensioning Institute (PTI) DC10.5 Design Parameters	Foundation Category		
	I	II	III
Thornthwaite Index	-20	-20	-20
Equilibrium Suction	3.9	3.9	3.9
Edge Lift Moisture Variation Distance, e_M (Feet)	5.3	5.1	4.9
Edge Lift, y_M (Inches)	0.61	1.10	1.58
Center Lift Moisture Variation Distance, e_M (Feet)	9.0	9.0	9.0
Center Lift, y_M (Inches)	0.30	0.47	0.66

11.8.12 The foundations for the post-tensioned slabs should be embedded in accordance with the recommendations of the structural engineer. If a post-tensioned mat foundation system is planned, the slab should possess a thickened edge with a minimum width of 12 inches and extend below the clean sand or crushed rock layer.

11.8.13 If the structural engineer proposes a post-tensioned foundation design method other than PTI, DC 10.5:

- The deflection criteria presented in Table 11.8.4 are still applicable.
- Interior stiffener beams should be used for Foundation Categories II and III.
- The width of the perimeter foundations should be at least 12 inches.
- The perimeter footing embedment depths should be at least 12 inches, 18 inches and 24 inches for foundation categories I, II, and III, respectively. The embedment depths should be measured from the lowest adjacent pad grade.

- 11.8.14 Foundation systems for the lots that possess a foundation Category I and a “very low” expansion potential (expansion index of 20 or less) can be designed using the method described in Section 1808 of the 2022 CBC. If post-tensioned foundations are planned, an alternative, commonly accepted design method (other than PTI) can be used. However, the post-tensioned foundation system should be designed with a total and differential deflection of 1 inch. Geocon Incorporated should be contacted to review the plans and provide additional information, if necessary.
- 11.8.15 If an alternate design method is contemplated, Geocon Incorporated should be contacted to evaluate if additional expansion index testing should be performed to identify the lots that possess a “very low” expansion potential (expansion index of 20 or less).
- 11.8.16 Our experience indicates post-tensioned slabs may be susceptible to excessive edge lift from tensioning, regardless of the underlying soil conditions. Placing reinforcing steel at the bottom of the perimeter footings and the interior stiffener beams may mitigate this potential. The structural engineer should design the foundation system to reduce the potential of edge lift occurring for the proposed structures.
- 11.8.17 During the construction of the post-tension foundation system, the concrete should be placed monolithically. Under no circumstances should cold joints form between the footings/grade beams and the slab during the construction of the post-tension foundation system unless designed by the structural engineer.
- 11.8.18 Isolated footings outside of the slab area, if present, should have the minimum embedment depth and width recommended for conventional foundations for a particular Foundation Category. The use of isolated footings, which are located beyond the perimeter of the building and support structural elements connected to the building, are not recommended for Category III. Where this condition cannot be avoided, the isolated footings should be connected to the building foundation system with grade beams. In addition, consideration should be given to connecting patio slabs, which exceed 5 feet in width, to the building foundation to reduce the potential for future separation to occur.
- 11.8.19 Interior stiffening beams should be incorporated into the design of the foundation system in accordance with the PTI design procedures.
- 11.8.20 Special subgrade presaturation is not deemed necessary prior to placing concrete; however, the exposed foundation and slab subgrade soil should be moisture conditioned, as necessary, to maintain a moist condition as would be expected in any such concrete placement.

11.8.21 Where buildings or other improvements are planned near the top of a slope 3:1 (horizontal:vertical) or steeper, special foundation and/or design considerations are recommended due to the tendency for lateral soil movement to occur.

- For fill slopes less than 20 feet high or cut slopes regardless of height, footings should be deepened such that the bottom outside edge of the footing is at least 7 feet horizontally from the face of the slope.
- When located next to a descending 3:1 (horizontal:vertical) fill slope or steeper, the foundations should be extended to a depth where the minimum horizontal distance is equal to $H/3$ (where H equals the vertical distance from the top of the fill slope to the base of the fill soil) with a minimum of 7 feet but need not exceed 40 feet. The horizontal distance is measured from the outer, deepest edge of the footing to the face of the slope. A post-tensioned slab and foundation system or mat foundation system can be used to reduce the potential for distress in the structures associated with strain softening and lateral fill extension. Specific design parameters or recommendations for either of these alternatives can be provided once the building location and fill slope geometry have been determined.
- If swimming pools are planned, Geocon Incorporated should be contacted for a review of specific site conditions.
- Swimming pools located within 7 feet of the top of cut or fill slopes are not recommended. Where such a condition cannot be avoided, the portion of the swimming pool wall within 7 feet of the slope face be designed assuming that the adjacent soil provides no lateral support. This recommendation applies to fill slopes up to 30 feet in height, and cut slopes regardless of height. For swimming pools located near the top of fill slopes greater than 30 feet in height, additional recommendations may be required and Geocon Incorporated should be contacted for a review of specific site conditions.
- Although other improvements, which are relatively rigid or brittle, such as concrete flatwork or masonry walls, may experience some distress if located near the top of a slope, it is generally not economical to mitigate this potential. It may be possible, however, to incorporate design measures which would permit some lateral soil movement without causing extensive distress. Geocon Incorporated should be consulted for specific recommendations.

11.8.22 The recommendations of this report are intended to reduce the potential for cracking of slabs and foundations due to expansive soil (if present), differential settlement of fill soil with varying thicknesses. However, even with the incorporation of the recommendations presented herein, foundations, stucco walls, and slabs-on-grade placed on such conditions may still exhibit some cracking due to soil movement and/or shrinkage. The occurrence of concrete shrinkage cracks is independent of the supporting soil characteristics. Their occurrence may be reduced by limiting the slump of the concrete, proper concrete placement and curing, and

by the placement of crack control joints at periodic intervals, in particular, where re-entrant slab corners occur.

- 11.8.23 Concrete slabs should be provided with adequate crack-control joints, construction joints and/or expansion joints to reduce unsightly shrinkage cracking. The design of joints should consider criteria of the American Concrete Institute when establishing crack-control spacing. Additional steel reinforcing, concrete admixtures and/or closer crack control joint spacing should be considered where concrete-exposed finished floors are planned.
- 11.8.24 Geocon Incorporated should be consulted to provide additional design parameters as required by the structural engineer.
- 11.8.25 We should observe the foundation excavations prior to the placement of reinforcing steel to check that the exposed soil conditions are similar to those expected and that they have been extended to the appropriate bearing strata. If unexpected soil conditions are encountered, foundation modifications may be required.

11.9 Exterior Concrete Flatwork

- 11.9.1 Exterior concrete flatwork not subject to vehicular traffic should be constructed in accordance with the recommendations presented in Table 11.9. The recommended steel reinforcement would help reduce the potential for cracking.

**TABLE 11.9
MINIMUM CONCRETE FLATWORK RECOMMENDATIONS**

Expansion Index, EI	Minimum Steel Reinforcement* Options	Minimum Thickness
EI ≤ 90	6x6-W2.9/W2.9 (6x6-6/6) welded wire mesh	4 Inches
	No. 3 Bars 18 inches on center, Both Directions	
EI ≤ 130	4x4-W4.0/W4.0 (4x4-4/4) welded wire mesh	4 Inches
	No. 4 Bars 12 inches on center, Both Directions	

*In excess of 8 feet square.

- 11.9.2 The subgrade soil should be properly moisturized and compacted prior to the placement of steel and concrete. The subgrade soil should be compacted to a dry density of at least 90 percent of the laboratory maximum dry density near to slightly above optimum moisture content in accordance with ASTM D 1557.

- 11.9.3 Even with the incorporation of the recommendations of this report, the exterior concrete flatwork has a potential to experience some uplift due to expansive soil beneath grade. The steel reinforcement should overlap continuously in flatwork to reduce the potential for vertical offsets within flatwork. Additionally, flatwork should be structurally connected to the curbs, where possible, to reduce the potential for offsets between the curbs and the flatwork.
- 11.9.4 Where exterior flatwork abuts the structure at entrant or exit points, the exterior slab should be dowelled into the structure's foundation stemwall. This recommendation is intended to reduce the potential for differential elevations that could result from differential settlement or minor heave of the flatwork. Dowelling details should be designed by the project structural engineer.
- 11.9.5 The recommendations presented herein are intended to reduce the potential for cracking of exterior slabs as a result of differential movement. However, even with the incorporation of the recommendations presented herein, slabs-on-grade will still crack. The occurrence of concrete shrinkage cracks is independent of the soil supporting characteristics. Their occurrence may be reduced and/or controlled by limiting the slump of the concrete, the use of crack control joints and proper concrete placement and curing. Crack control joints should be spaced at intervals no greater than 12 feet. Literature provided by the Portland Concrete Association (PCA) and American Concrete Institute (ACI) present recommendations for proper concrete mix, construction, and curing practices, and should be incorporated into project construction.

11.10 Conventional Retaining Walls

- 11.10.1 Retaining walls should be designed using the values presented in Table 11.10.1. Soil with an expansion index (EI) of greater than 90 should not be used as backfill material behind retaining walls.

**TABLE 11.10.1
RETAINING WALL DESIGN RECOMMENDATIONS**

Parameter	Value
Active Soil Pressure, A (Fluid Density, Level Backfill)	40 pcf
Active Soil Pressure, A (Fluid Density, 2:1 Sloping Backfill)	55 pcf
Restrained Walls Additional Uniform Pressure (0 to 8 Feet High)	7H psf
Restrained Walls Additional Uniform Pressure (8+ Feet High)	13H psf
Seismic Pressure	15H psf
Expected Expansion Index for the Subject Property	EI _≤ 90

H equals the height of the retaining portion of the wall

11.10.2 The project retaining walls should be designed as shown in the Retaining Wall Loading Diagram.

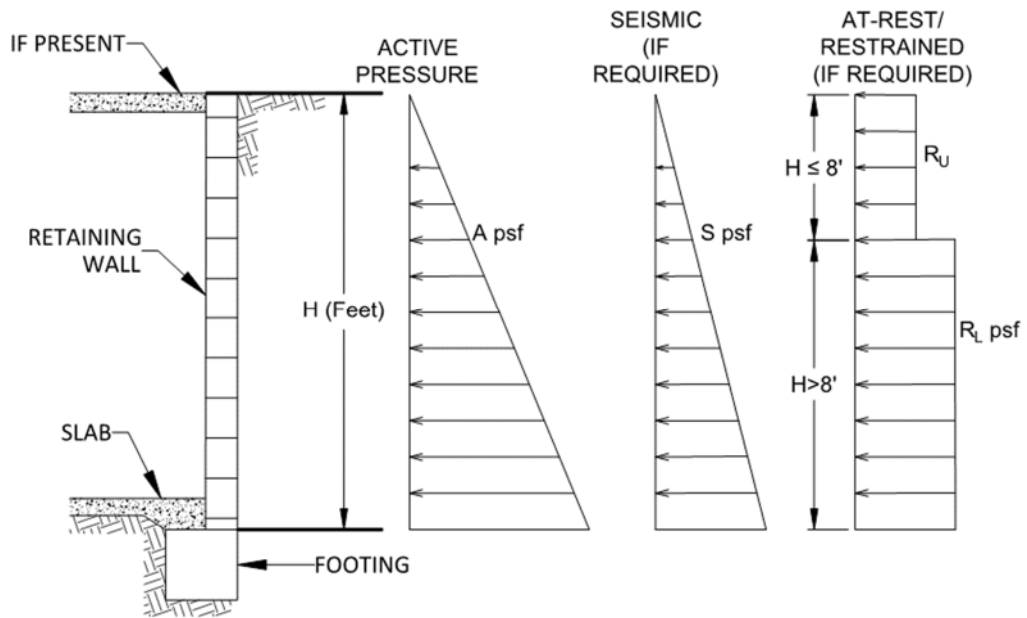

Retaining Wall Loading Diagram

11.10.3 Unrestrained walls are those that are allowed to rotate more than $0.001H$ (where H equals the height of the retaining portion of the wall) at the top of the wall. Where walls are restrained from movement at the top (at-rest condition), an additional uniform pressure should be added to the active soil pressure for walls. For retaining walls subject to vehicular loads within a horizontal distance equal to two-thirds the wall height, a surcharge equivalent to 2 feet of fill soil should be added.

11.10.4 The structural engineer should determine the Seismic Design Category for the project in accordance with Section 1613 of the 2022 CBC or Section 11.6 of ASCE 7-10. For structures assigned to Seismic Design Category of D, E, or F, retaining walls that support more than 6 feet of backfill should be designed with seismic lateral pressure in accordance with Section 1803.5.12 of the 2022 CBC. The seismic load is dependent on the retained height where H is the height of the wall, in feet, and the calculated loads result in pounds per square foot (psf) exerted at the base of the wall and zero at the top of the wall.

11.10.5 Retaining walls should be designed to ensure stability against overturning sliding, and excessive foundation pressure. Where a keyway is extended below the wall base with the intent to engage passive pressure and enhance sliding stability, it is not necessary to consider active pressure on the keyway.

11.10.6 Drainage openings through the base of the wall (weep holes) should not be used where the seepage could be a nuisance or otherwise adversely affect the property adjacent to the base of the wall. The recommendations herein assume a properly compacted granular (EI of 90 or less) free draining backfill material with no hydrostatic forces or imposed surcharge load. The retaining wall should be properly drained as shown in the Typical Retaining Wall Drainage Detail. If conditions different than those described are expected, or if specific drainage details are desired, Geocon Incorporated should be contacted for additional recommendations.

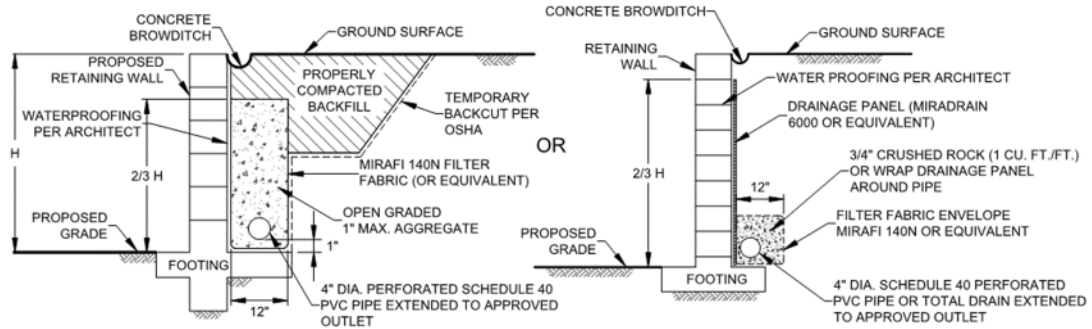

Typical Retaining Wall Drainage Detail

11.10.7 The retaining walls may be designed using either the active and restrained (at-rest) loading condition or the active and seismic loading condition as suggested by the structural engineer. Typically, it appears the design of the restrained condition for retaining wall loading may be adequate for the seismic design of the retaining walls. However, the active earth pressure combined with the seismic design load should be reviewed and also considered in the design of the retaining walls.

11.10.8 In general, wall foundations having should be designed in accordance with Table 11.10.2. The proximity of the foundation to the top of a slope steeper than 3:1 could impact the allowable soil bearing pressure. Therefore, retaining wall foundations should be deepened such that the bottom outside edge of the footing is at least 7 feet horizontally from the face of the slope.

**TABLE 11.10.2
SUMMARY OF RETAINING WALL FOUNDATION RECOMMENDATIONS**

Parameter	Value
Minimum Retaining Wall Foundation Width	12 inches
Minimum Retaining Wall Foundation Depth	12 Inches
Minimum Steel Reinforcement	Per Structural Engineer
Allowable Bearing Capacity	2,000 psf
Estimated Total Settlement From Footing Loads	1 Inch
Estimated Differential Settlement From Footing Loads	½ Inch in 40 Feet

- 11.10.9 The recommendations presented herein are generally applicable to the design of rigid concrete or masonry retaining walls. In the event that other types of walls (such as mechanically stabilized earth [MSE] walls, soil nail walls, or soldier pile walls) are planned, Geocon Incorporated should be consulted for additional recommendations.
- 11.10.10 Unrestrained walls will move laterally when backfilled and loading is applied. The amount of lateral deflection is dependent on the wall height, the type of soil used for backfill, and loads acting on the wall. The retaining walls and improvements above the retaining walls should be designed to incorporate an appropriate amount of lateral deflection as determined by the structural engineer.
- 11.10.11 Soil contemplated for use as retaining wall backfill, including import materials, should be identified in the field prior to backfill. At that time, Geocon Incorporated should obtain samples for laboratory testing to evaluate its suitability. Modified lateral earth pressures may be necessary if the backfill soil does not meet the required expansion index or shear strength. City or regional standard wall designs, if used, are based on a specific active lateral earth pressure and/or soil friction angle. In this regard, on-site soil to be used as backfill may or may not meet the values for standard wall designs. Geocon Incorporated should be consulted to assess the suitability of the on-site soil for use as wall backfill if standard wall designs will be used.

11.11 Lateral Loading

- 11.11.1 Table 11.11 should be used to help design the proposed structures and improvements to resist lateral loads for the design of footings or shear keys. The allowable passive pressure assumes a horizontal surface extending at least 5 feet, or three times the surface generating the passive pressure, whichever is greater. The upper 12 inches of material in areas not protected by floor slabs or pavement should not be included in design for passive resistance.

**TABLE 11.11
SUMMARY OF LATERAL LOAD DESIGN RECOMMENDATIONS**

Parameter	Value
Passive Pressure Fluid Density	350 pcf
Coefficient of Friction (Concrete and Soil)	0.35
Coefficient of Friction (Along Vapor Barrier)	0.2 to 0.25*

*Per manufacturer's recommendations.

11.11.2 The passive and frictional resistant loads can be combined for design purposes. The lateral passive pressures may be increased by one-third when considering transient loads due to wind or seismic forces.

11.12 Preliminary Pavement Recommendations

11.12.1 We calculated the flexible pavement sections in general conformance with the *Caltrans Method of Flexible Pavement Design* (Highway Design Manual, Section 608.4) using an estimated Traffic Index (TI) of 5.0, 6.0, 7.5, 8.0 and 8.5 for the planned roadways in accordance with the City of Chula Vista Subdivision Manual Section 3-400 (2012). The final pavement sections for roadways should be based on the R-Value of the subgrade soils encountered at final subgrade elevation. Streets should be designed in accordance with the City of Chula specifications when final Traffic Indices and R-Value test results of subgrade soil are completed. Based on the results of our laboratory R-Value testing, we used an R-Value of 15 for the subgrade soil for the purposes of this preliminary analysis. Table 11.12.1 presents the preliminary flexible pavement sections. The City of Chula Vista will likely provide the required pavement section thicknesses subsequent to reviewing laboratory R-Values once the utilities have been installed.

**TABLE 11.12.1
PRELIMINARY FLEXIBLE PAVEMENT SECTION**

Location	Assumed Traffic Index	Assumed Subgrade R-Value	Asphalt Concrete (inches)	Aggregate Base (inches)
Residential Cul-De-Sac	5.0	15	3	8
Residential	6.0	15	3.5	11
Class III Collector	7.0	15	4	13
Class II Collector (Secondary Village Entry)	8.0	15	5	15
Class I Collector (Village Entry)	8.5	15	5	17

11.12.2 Prior to placing base materials, the upper 12 inches of the subgrade soil should be scarified, moisture conditioned as necessary, and recompacted to a dry density of at least 95 percent of the laboratory maximum dry density near to slightly above optimum moisture content as determined by ASTM D 1557. Similarly, the base material should be compacted to a dry density of at least 95 percent of the laboratory maximum dry density near to slightly above optimum moisture content. Asphalt concrete should be compacted to a density of at least 95 percent of the laboratory Hveem density in accordance with ASTM D 2726.

- 11.12.3 The crushed aggregate base materials and asphalt concrete should conform to the *Standard Specifications for Public Works Construction (Greenbook)* and the *City of Chula Vista Standard Special Provisions*.
- 11.12.4 The base thickness can be reduced if a reinforcement geogrid is used during the installation of the pavement. Geocon should be contact for additional recommendations, if required.
- 11.12.5 A rigid Portland cement concrete (PCC) pavement section should be placed in driveway entrance aprons, trash bin loading/storage areas and loading dock areas. The concrete pad for trash truck areas should be large enough such that the truck wheels will be positioned on the concrete during loading. We calculated the rigid pavement section in general conformance with the procedure recommended by the American Concrete Institute report ACI 330-21 *Commercial Concrete Parking Lots and Site Paving Design and Construction – Guide*. Table 11.12.2 provides the traffic categories and design parameters used for the calculations for 20-year design life.

**TABLE 11.12.2
TRAFFIC CATEGORIES**

Traffic Category	Description	Reliability (%)	Slabs Cracked at End of Design Life (%)
A	Car Parking Areas and Access Lanes	60	15
B	Entrance and Truck Service Lanes	60	15
E	Garbage or Fire Truck Lane	75	15

- 11.12.6 We used the parameters presented in Table 11.12.3 to calculate the pavement design sections. We should be contacted to provide updated design sections, if necessary.

**TABLE 11.12.3
RIGID PAVEMENT DESIGN PARAMETERS**

Design Parameter	Design Value
Modulus of subgrade reaction, k	100 pci
Modulus of rupture for concrete, M_R	500 psi
Concrete Compressive Strength	3,000 psi
Concrete Modulus of Elasticity, E	3,150,000

- 11.12.7 Based on the criteria presented herein, the PCC pavement sections should have a minimum thickness as presented in Table 11.12.4.

**TABLE 11.12.4
RIGID PAVEMENT RECOMMENDATIONS**

Location	Portland Cement Concrete (inches)
Parking Stalls (TC=A)	6
Driveways, Alleyways, and Heavy Truck and Fire Lane Areas (TC=C)	7

- 11.12.8 The PCC vehicular pavement should be placed over subgrade soil that is compacted to a dry density of at least 95 percent of the laboratory maximum dry density near to slightly above optimum moisture content.
- 11.12.9 Adequate joint spacing should be incorporated into the design and construction of the rigid pavement in accordance with Table 11.12.5.

**TABLE 11.12.5
MAXIMUM JOINT SPACING**

Pavement Thickness, T (Inches)	Maximum Joint Spacing (Feet)
$4 < T < 5$	10
$5 \leq T < 6$	12.5
$6 \leq T$	15

- 11.12.10 The rigid pavement should also be designed and constructed incorporating the parameters presented in Table 11.12.6.

**TABLE 11.12.6
ADDITIONAL RIGID PAVEMENT RECOMMENDATIONS**

Subject	Value
Thickened Edge	1.2 Times Slab Thickness Adjacent to Structures
	1.5 Times Slab Thickness Adjacent to Soil
	Minimum Increase of 2 Inches
	4 Feet Wide
Crack Control Joint Depth	Early Entry Sawn = $T/6$ to $T/5$, 1.25 Inch Minimum
	Conventional (Tooled or Conventional Sawing) = $T/4$ to $T/3$
Crack Control Joint Width	$1/4$ -Inch for Sealed Joints and Per Sealer Manufacturer's Recommendations
	$1/16$ - to $1/4$ -Inch is Common for Unsealed Joints

- 11.12.11 Reinforcing steel will not be necessary within the concrete for geotechnical purposes with the possible exception of dowels at construction joints as discussed herein.
- 11.12.12 To control the location and spread of concrete shrinkage cracks, crack-control joints (weakened plane joints) should be included in the design of the concrete pavement slab. Crack-control joints should not exceed 30 times the slab thickness with a maximum spacing of 15 feet for the 7-inch-thick slabs and should be sealed with an appropriate sealant to prevent the migration of water through the control joint to the subgrade materials. The depth of the crack-control joints should be determined by the referenced ACI report.
- 11.12.13 To provide load transfer between adjacent pavement slab sections, a butt-type construction joint should be constructed. The butt-type joint should be thickened by at least 20 percent at the edge and taper back at least 4 feet from the face of the slab. As an alternative to the butt-type construction joint, dowelling can be used between construction joints for pavements of 7 inches or thicker. As discussed in the referenced ACI guide, dowels should consist of smooth, 1-inch-diameter reinforcing steel 14 inches long embedded a minimum of 6 inches into the slab on either side of the construction joint. Dowels should be located at the midpoint of the slab, spaced at 12 inches on center and lubricated to allow joint movement while still transferring loads. In addition, tie bars should be installed at the as recommended in Section 3.8.3 of the referenced ACI guide. The structural engineer should provide other alternative recommendations for load transfer.

11.13 Slope Maintenance

- 11.13.1 Slopes that are steeper than 3:1 (horizontal to vertical) may, under conditions which are both difficult to prevent and predict, be susceptible to near surface (surficial) slope instability. The instability is typically limited to the outer three feet of a portion of the slope and usually does not directly impact the improvements on the pad areas above or below the slope. The occurrence of surficial instability is more prevalent on fill slopes and is generally preceded by a period of heavy rainfall, excessive irrigation, or the migration of subsurface seepage. The disturbance and/or loosening of the surficial soils, as might result from root growth, soil expansion, or excavation for irrigation lines and slope planting, may also be a significant contributing factor to surficial instability. It is, therefore, recommended that, to the maximum extent practical: (a) disturbed/loosened surficial soils be either removed or properly recompacted, (b) irrigation systems be periodically inspected and maintained to eliminate leaks and excessive irrigation, and (c) surface drains on and adjacent to slopes be periodically maintained to preclude ponding or erosion. It should be noted that although the incorporation of the recommendations herein should reduce the potential for surficial slope instability, it will not eliminate the possibility, and, therefore, it may be necessary to rebuild or repair a portion of the project's slopes in the future.

- 11.13.2 To help mitigate slope creep from occurring, plants with variable root depth should be installed soon after the construction of the slopes. In addition, rodent abatement is also important as part of the slope maintenance.
- 11.13.3 The planned buildings and structures should be setback in accordance with CBC Section 18 and as recommended herein. Some mitigation measures could include not placing large exterior concrete slabs at the top of the slopes but installing bands of concrete that would allow some lateral movements. Also, pilasters from walls could be separated from the walls to allow some lateral movement without damaging the walls.
- 11.13.4 The soil creep zone is usually isolated to the outer 5 to 10 feet of the slope face. The planned residential structures and improvements are not planned within this zone. Foundation recommendations for walls located adjacent to slopes are provided in the foundation section of this report. However, if planned retaining walls or similar improvements that are prone to creeping are proposed at the top of slopes, we would recommend that deepened footings be incorporated to help reduce the effect of lateral fill extension.

11.14 Site Drainage and Moisture Protection

- 11.14.1 Adequate site drainage is critical to reduce the potential for differential soil movement, erosion and subsurface seepage. Under no circumstances should water be allowed to pond adjacent to footings. The site should be graded and maintained such that surface drainage is directed away from structures in accordance with 2022 CBC 1804.4 or other applicable standards. In addition, surface drainage should be directed away from the top of slopes into swales or other controlled drainage devices. Roof and pavement drainage should be directed into conduits that carry runoff away from the proposed structure.
- 11.14.2 In the case of basement walls or building walls retaining landscaping areas, a water-proofing system should be used on the wall and joints, and a Miradrain drainage panel (or similar) should be placed over the waterproofing. The project architect or civil engineer should provide detailed specifications on the plans for all waterproofing and drainage.
- 11.14.3 Underground utilities should be leak free. Utility and irrigation lines should be checked periodically for leaks, and detected leaks should be repaired promptly. Detrimental soil movement could occur if water is allowed to infiltrate the soil for prolonged periods of time.
- 11.14.4 If detention basins, bioswales, retention basins, water infiltration, low impact development (LID), or storm water management devices are being considered, Geocon Incorporated should

be retained to provide recommendations pertaining to the geotechnical aspects of possible impacts and design.

- 11.14.5 If not properly constructed, there is a potential for distress to improvements and properties located hydrologically down gradient or adjacent to these devices. Factors such as the amount of water to be detained, its residence time, and soil permeability have an important effect on seepage transmission and the potential adverse impacts that may occur if the storm water management features are not properly designed and constructed. Based on our experience with similar clayey soil conditions, infiltration areas are considered infeasible due to the poor percolation and lateral migration characteristics. We have not performed a hydrogeology study at the site. Down-gradient and adjacent structures may be subjected to seeps, movement of foundations and slabs, or other impacts as a result of water infiltration.

11.15 Grading and Foundation Plan Review

- 11.15.1 Geocon Incorporated should review the final grading and foundation plans prior to finalization to check their compliance with the recommendations of this report and evaluate the need for additional comments, recommendations, and/or analyses.

11.16 Testing and Observation Services During Construction

- 11.16.1 Geocon Incorporated should provide geotechnical testing and observation services during the grading operations, foundation construction, utility installation, retaining wall backfill and pavement installation. Table 11.16 presents the typical geotechnical observations we would expect for the proposed improvements.

**TABLE 11.16
EXPECTED GEOTECHNICAL TESTING AND OBSERVATION SERVICES**

Construction Phase	Observations	Expected Time Frame
Grading	Base of Removal	Part Time During Removals
	Geologic Logging	Part Time to Full Time
	Fill Placement and Soil Compaction	Full Time
Foundations	Foundation Excavation Observations	Part Time
Utility Backfill	Fill Placement and Soil Compaction	Part Time to Full Time
Retaining Wall Backfill	Fill Placement and Soil Compaction	Part Time to Full Time
Subgrade for Sidewalks, Curb/Gutter and Pavement	Soil Compaction	Part Time
Pavement Construction	Base Placement and Compaction	Part Time
	Asphalt Concrete Placement and Compaction	Full Time

LIMITATIONS AND UNIFORMITY OF CONDITIONS

1. The firm that performed the geotechnical investigation for the project should be retained to provide testing and observation services during construction to provide continuity of geotechnical interpretation and to check that the recommendations presented for geotechnical aspects of site development are incorporated during site grading, construction of improvements, and excavation of foundations. If another geotechnical firm is selected to perform the testing and observation services during construction operations, that firm should prepare a letter indicating their intent to assume the responsibilities of project geotechnical engineer of record. A copy of the letter should be provided to the regulatory agency for their records. In addition, that firm should provide revised recommendations concerning the geotechnical aspects of the proposed development, or a written acknowledgement of their concurrence with the recommendations presented in our report. They should also perform additional analyses deemed necessary to assume the role of Geotechnical Engineer of Record.
2. The recommendations of this report pertain only to the site investigated and are based upon the assumption that the soil conditions do not deviate from those disclosed in the investigation. If any variations or undesirable conditions are encountered during construction, or if the proposed construction will differ from that anticipated herein, Geocon Incorporated should be notified so that supplemental recommendations can be given. The evaluation or identification of the potential presence of hazardous or corrosive materials was not part of the scope of services provided by Geocon Incorporated.
3. This report is issued with the understanding that it is the responsibility of the owner or his representative to ensure that the information and recommendations contained herein are brought to the attention of the architect and engineer for the project and incorporated into the plans, and the necessary steps are taken to see that the contractor and subcontractors carry out such recommendations in the field.
4. The findings of this report are valid as of the present date. However, changes in the conditions of a property can occur with the passage of time, whether they be due to natural processes or the works of man on this or adjacent properties. In addition, changes in applicable or appropriate standards may occur, whether they result from legislation or the broadening of knowledge. Accordingly, the findings of this report may be invalidated wholly or partially by changes outside our control. Therefore, this report is subject to review and should not be relied upon after a period of three years.

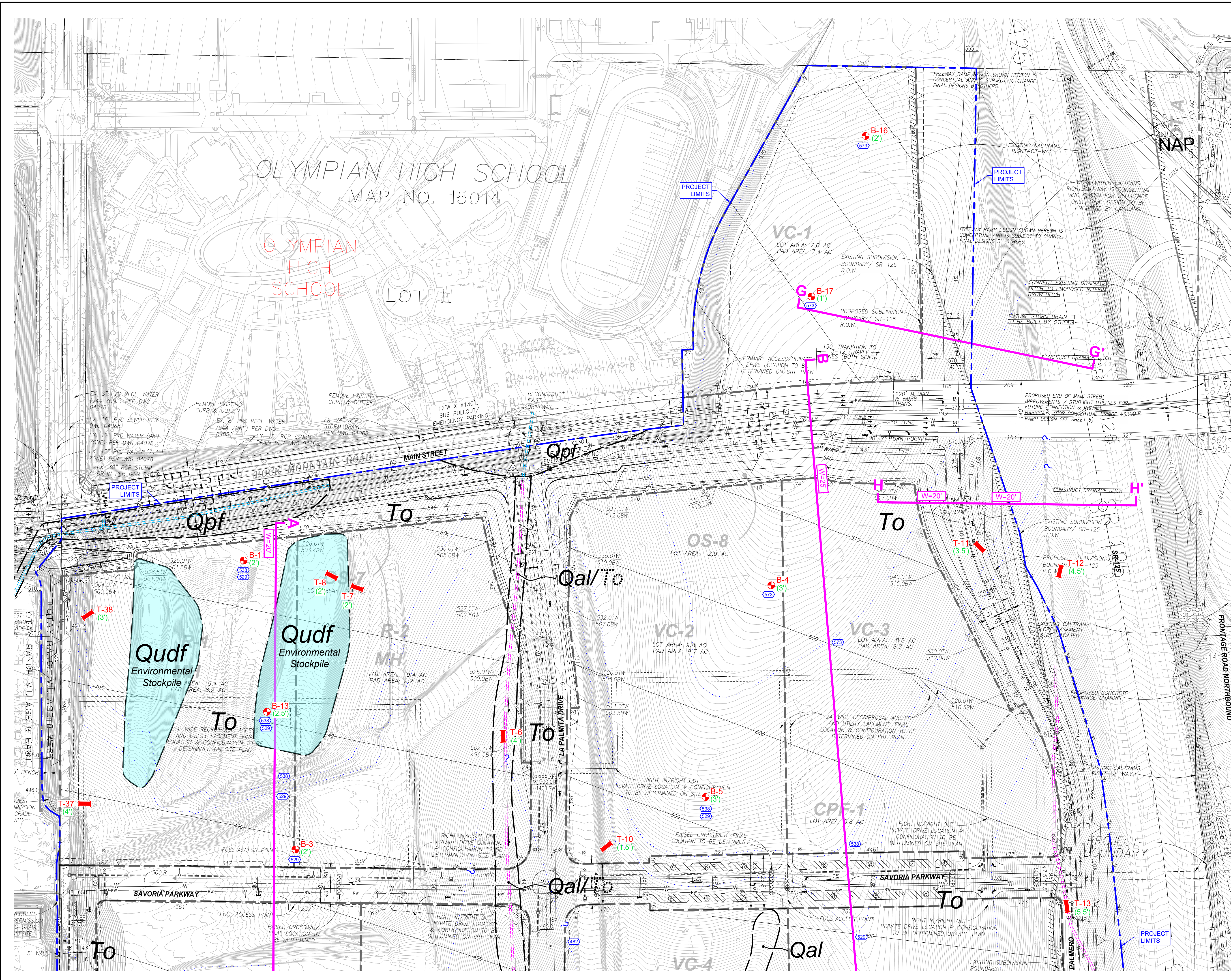

OLYMPIAN HIGH SCHOOL
MAP NO. 15014

OLYMPIAN HIGH SCHOOL

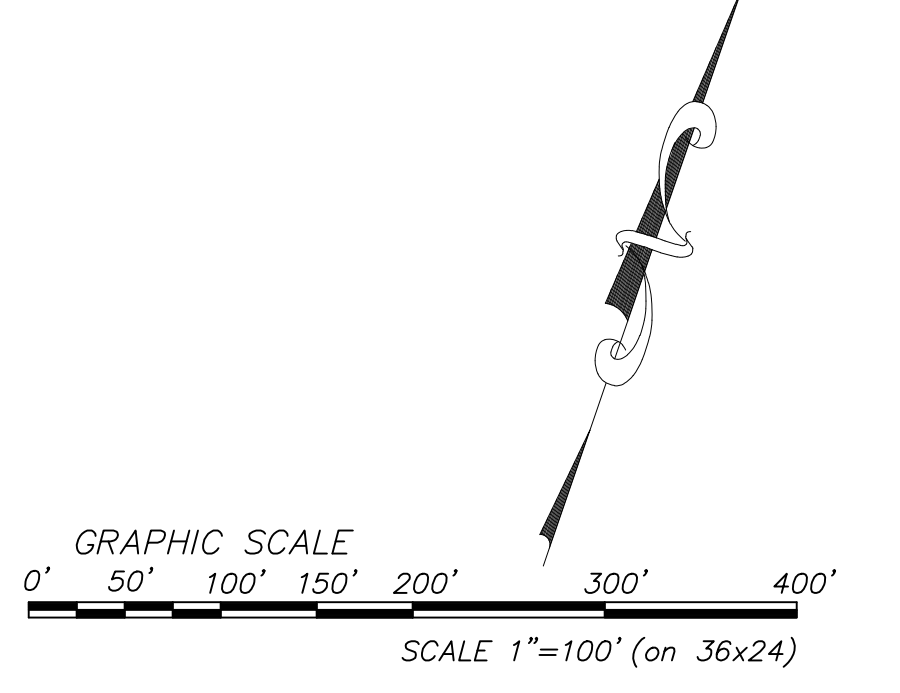
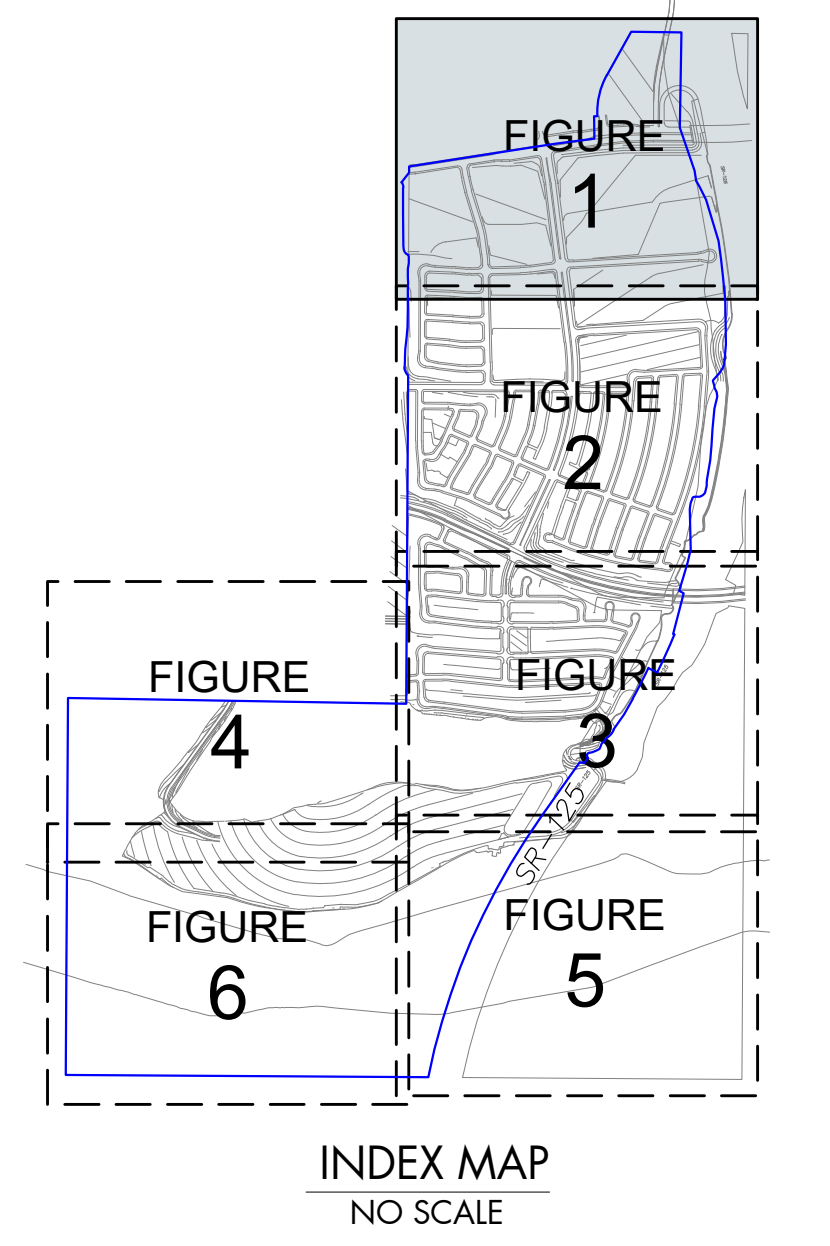

GEOCON LEGEND

- QcfCOMPACTED FILL
- QudfUNDOCUMENTED FILL
- QpfPREVIOUSLY PLACED FILL
- QalALLUVIUM
- QtTERRACE DEPOSITS (Dotted Where Buried)
- ToOTAY FORMATION (Dotted Where Buried)
- To_gOTAY FORMATION (Gritstone) (Dotted Where Buried)
- ~APPROX. LOCATION OF GEOLOGIC CONTACT (Dotted Where Buried, Queried Where Uncertain)
- B-19APPROX. LOCATION OF EXPLORATORY BORING
- T-57APPROX. LOCATION OF EXPLORATORY TRENCH
- (3')APPROX. DEPTH TO FORMATIONAL (In Feet)
- HAPPROX. LOCATION OF GEOLOGIC CROSS SECTIONS
- W=30'REQUIRED WIDTH OF BUTTRESS (In Feet)
-APPROX. LOCATION OF EXISTING 8-INCH SOIL-ROCK FILL SUBDRAIN
-APPROX. LOCATION OF EXISTING 6-INCH SOIL-ROCK FILL SUBDRAIN
-APPROX. LOCATION OF PROPOSED 8-INCH CANYON SUBDRAIN
-APPROX. LOCATION OF PROPOSED 6-INCH CANYON SUBDRAIN
-APPROX. LOCATION OF EXISTING 8-INCH SUBDRAIN (Geotechnics, 2005)
-APPROX. ELEVATION OF SUBDRAIN (In Feet, MSL)
- ?APPROX. LOCATION OF OBSERVED BENTONITE CLAYSTONE BED (Queried Where Uncertain)
- 423APPROX. ELEVATION OF OBSERVED BENTONITE CLAYSTONE BED (In Feet, MSL)
- 344APPROX. ELEVATION OF BASE OF FILL (In Feet, MSL)

GEOLOGIC MAP
OTAY RANCH - VILLAGE 8 EAST
CHULA VISTA, CALIFORNIA

<p>GEOCON INCORPORATED GEO TECHNICAL ■ ENVIRONMENTAL ■ MATERIALS 6940 FLANDERS DRIVE - SAN DIEGO, CALIFORNIA 92121 - 2974 PHONE 619 558 6900 - FAX 619 558 6159</p>	<p>SCALE 1" = 100'</p>	<p>DATE 05 - 05 - 2023</p>
	<p>PROJECT NO. G1006 - 52 - 05</p>	<p>SHEET 1 OF 6</p>

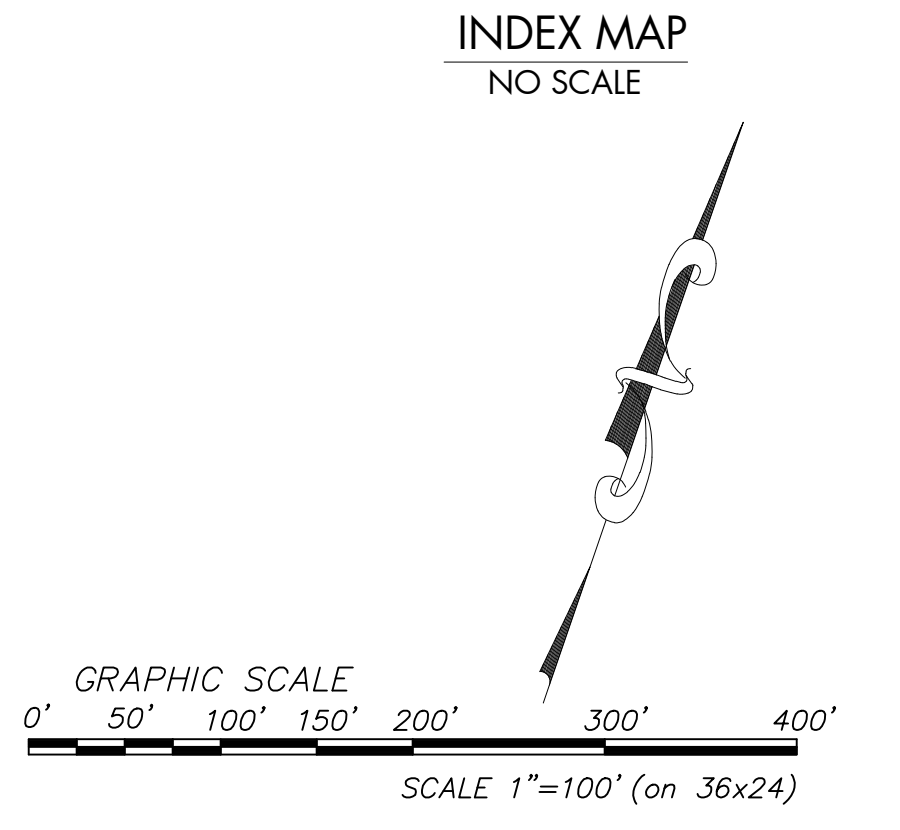
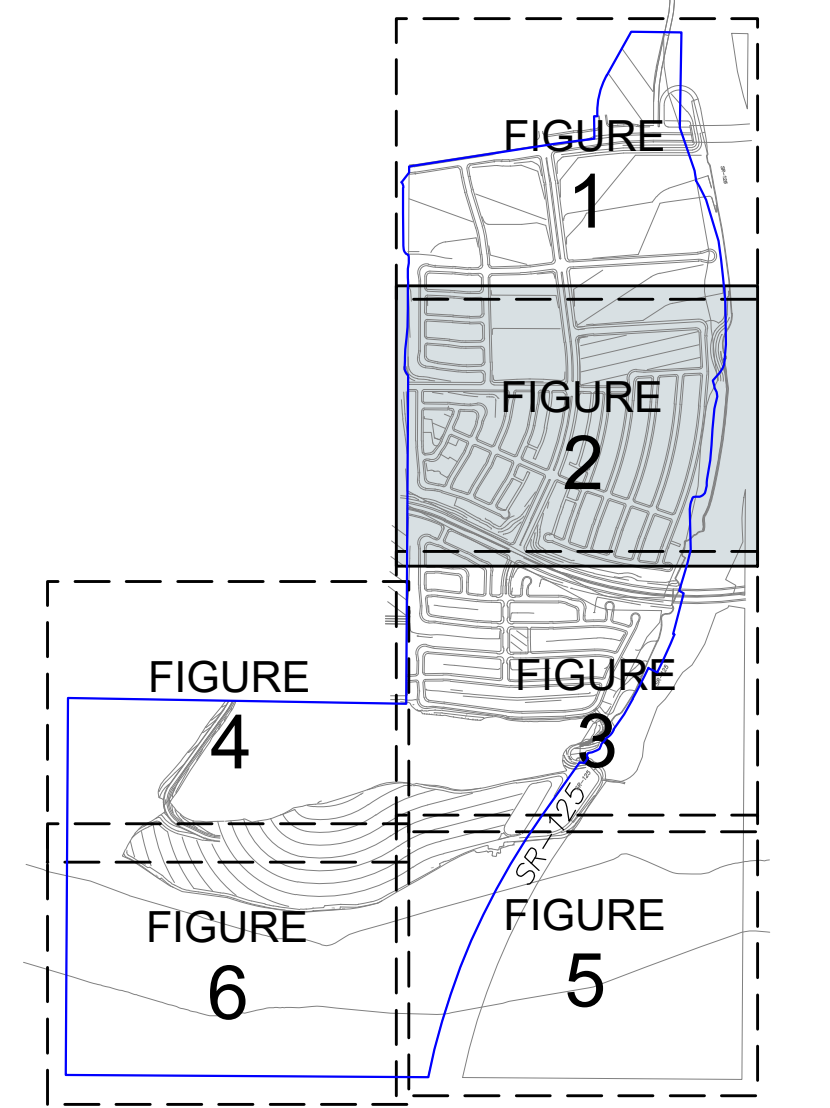
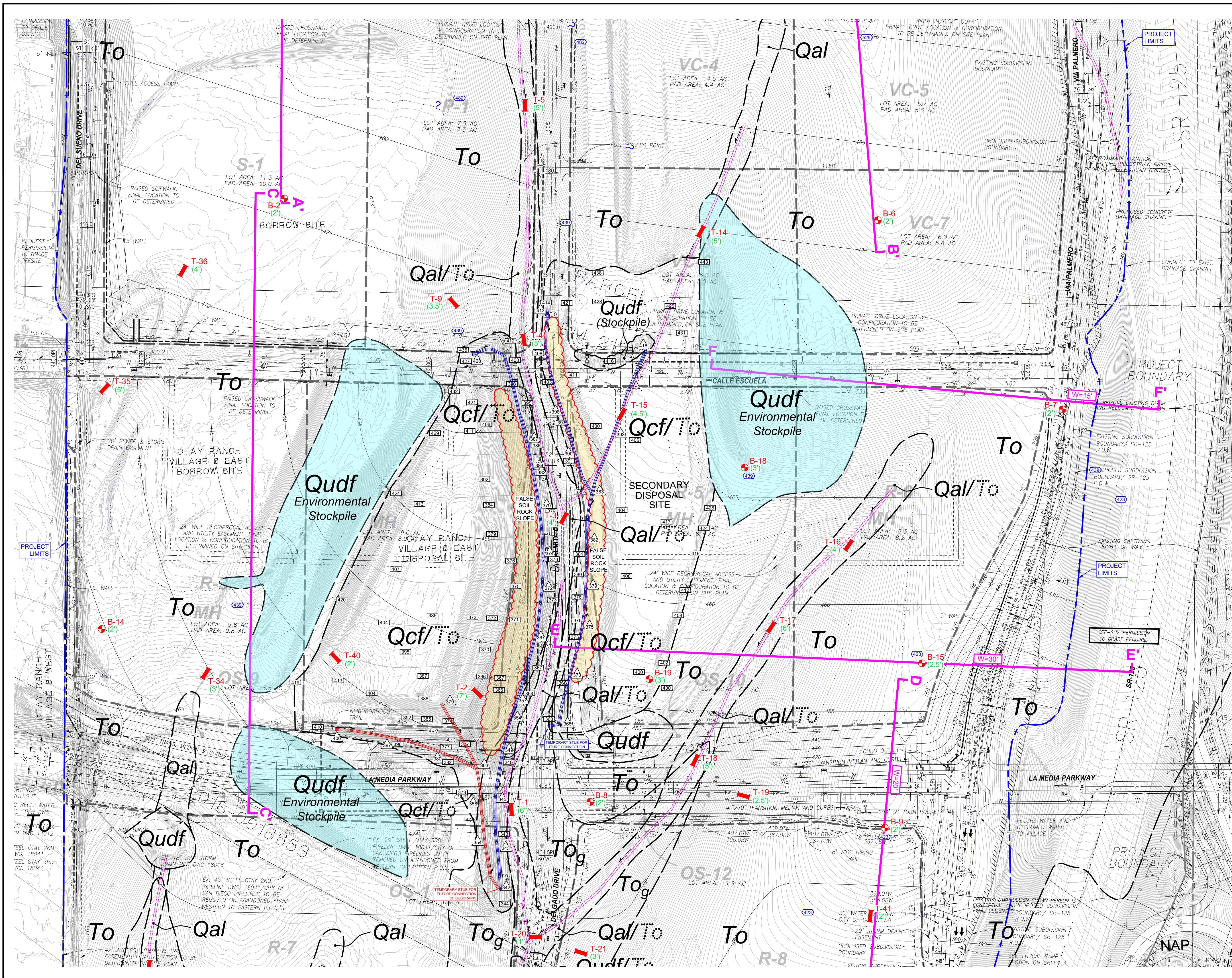

GEOCON LEGEND

- Qcf** COMPACTED FILL
- Qudf** UNDOCUMENTED FILL
- Qpf** PREVIOUSLY PLACED FILL
- Qal** ALLUVIUM
- Qt** TERRACE DEPOSITS (Dotted Where Buried)
- To** OTAY FORMATION (Dotted Where Buried)
- To_g** OTAY FORMATION (Griststone) (Dotted Where Buried)
- ~ APPROX. LOCATION OF GEOLOGIC CONTACT (Dotted Where Buried, Queried Where Uncertain)
- B-19 APPROX. LOCATION OF EXPLORATORY BORING
- T-57 APPROX. LOCATION OF EXPLORATORY TRENCH
- (3') APPROX. DEPTH TO FORMATIONAL (In Feet)
- H-H APPROX. LOCATION OF GEOLOGIC CROSS SECTIONS
- W=30' REQUIRED WIDTH OF BUTTRESS (In Feet)
- APPROX. LOCATION OF EXISTING 8-INCH SOIL-ROCK FILL SUBDRAIN
- APPROX. LOCATION OF EXISTING 6-INCH SOIL-ROCK FILL SUBDRAIN
- APPROX. LOCATION OF PROPOSED 8-INCH CANYON SUBDRAIN
- APPROX. LOCATION OF PROPOSED 6-INCH CANYON SUBDRAIN
- APPROX. LOCATION OF EXISTING 8-INCH SUBDRAIN (Geotechnics, 2005)
- APPROX. ELEVATION OF SUBDRAIN (In Feet, MSL)
- ? APPROX. LOCATION OF OBSERVED BENTONITE CLAYSTONE BED (Queried Where Uncertain)
- 423 APPROX. ELEVATION OF OBSERVED BENTONITE CLAYSTONE BED (In Feet, MSL)
- 344 APPROX. ELEVATION OF BASE OF FILL (In Feet, MSL)

GEOLOGIC MAP
OTAY RANCH - VILLAGE 8 EAST
CHULA VISTA, CALIFORNIA

<p>GEOCON INCORPORATED GEO TECHNICAL ■ ENVIRONMENTAL ■ MATERIALS 6940 FLANDERS DRIVE - SAN DIEGO, CALIFORNIA 92121-2974 PHONE: 619-538-6900 - FAX: 619-538-6159</p>	<p>SCALE 1" = 100'</p>	<p>DATE 05 - 05 - 2023</p>
	<p>PROJECT NO. G1006 - 52 - 05</p>	<p>SHEET 2 OF 6</p>

Revised: 05/05/2023 8:34AM | By: ALVIN LADRILLON | File Location: W:\1_GEO\TECH\1000\G1006-52-05\2023-05-05\G1006-52-05_Geo_Map_20.dwg

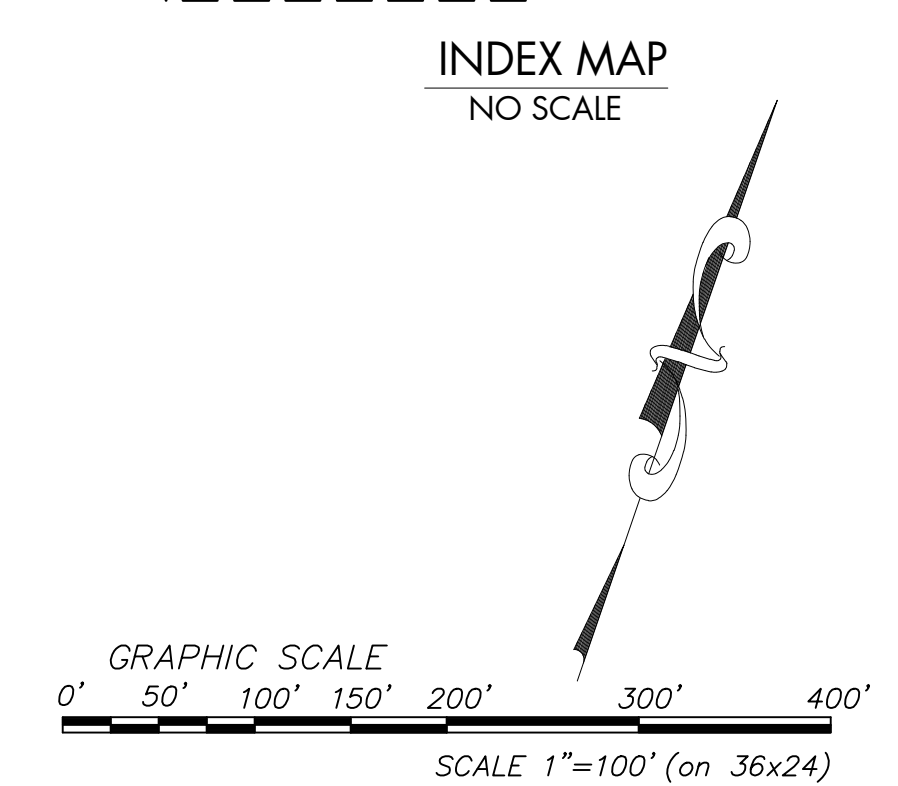
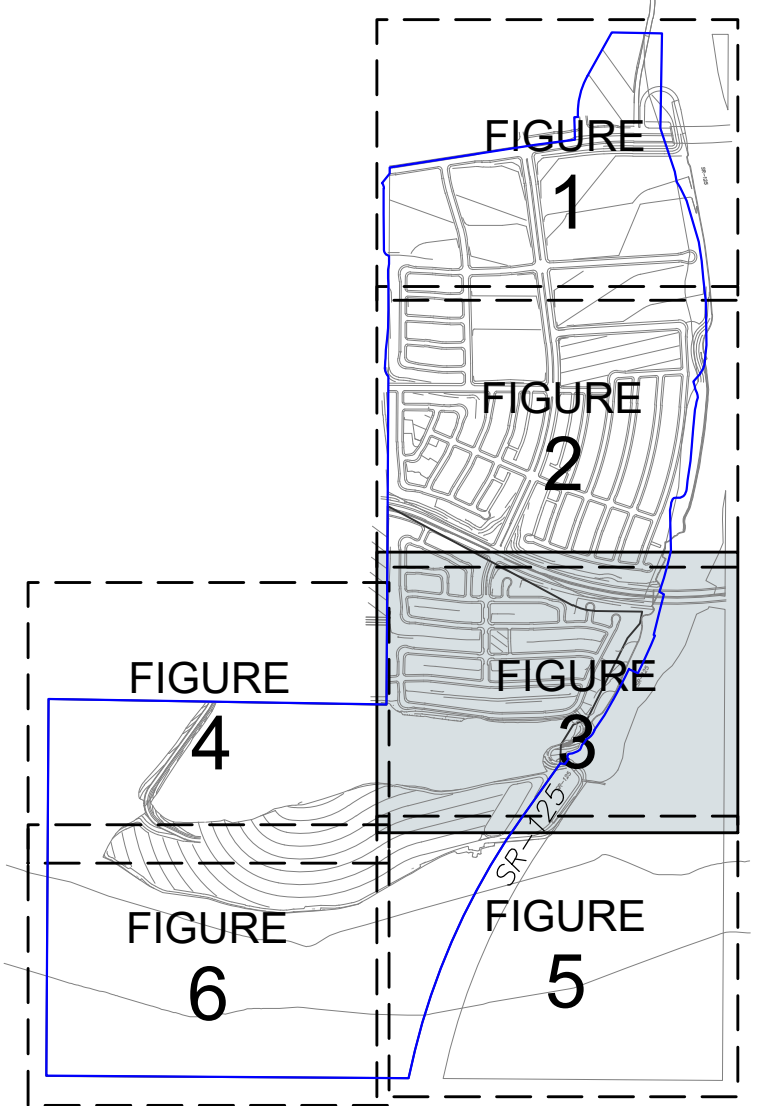
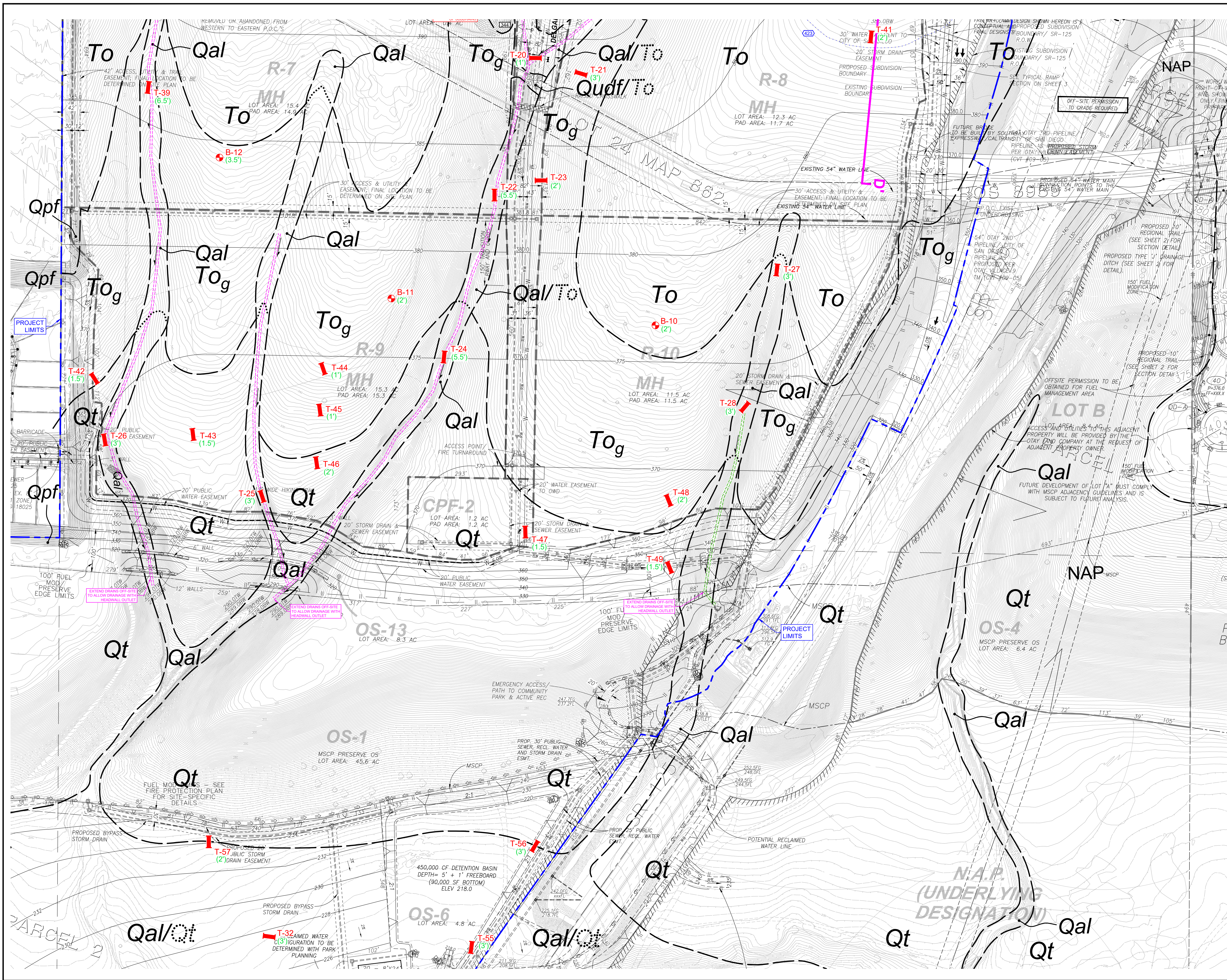

GEOCON LEGEND

- Qcf**COMPACTED FILL
- Qudf**UNDOCUMENTED FILL
- Qpf**PREVIOUSLY PLACED FILL
- Qal**ALLUVIUM
- Qt**TERRACE DEPOSITS (Dotted Where Buried)
- To**OTAY FORMATION (Dotted Where Buried)
- Toq**OTAY FORMATION (Griststone) (Dotted Where Buried)
-APPROX. LOCATION OF GEOLOGIC CONTACT (Dotted Where Buried, Queried Where Uncertain)
- B-10**APPROX. LOCATION OF EXPLORATORY BORING
- T-57**APPROX. LOCATION OF EXPLORATORY TRENCH
- (3)**APPROX. DEPTH TO FORMATIONAL (In Feet)
- H**APPROX. LOCATION OF GEOLOGIC CROSS SECTIONS
- W=30**REQUIRED WIDTH OF BUTTRESS (In Feet)
-APPROX. LOCATION OF EXISTING 8-INCH SOIL-ROCK FILL SUBDRAIN
-APPROX. LOCATION OF EXISTING 6-INCH SOIL-ROCK FILL SUBDRAIN
-APPROX. LOCATION OF PROPOSED 8-INCH CANYON SUBDRAIN
-APPROX. LOCATION OF PROPOSED 6-INCH CANYON SUBDRAIN
-APPROX. LOCATION OF EXISTING 8-INCH SUBDRAIN (Geotechnics, 2005)
-APPROX. ELEVATION OF SUBDRAIN (In Feet, MSL)
-APPROX. LOCATION OF OBSERVED BENTONITE CLAYSTONE BED (Queried Where Uncertain)
- 423**APPROX. ELEVATION OF OBSERVED BENTONITE CLAYSTONE BED (In Feet, MSL)
- 344**APPROX. ELEVATION OF BASE OF FILL (In Feet, MSL)

GEOLOGIC MAP	
OTAY RANCH - VILLAGE 8 EAST CHULA VISTA, CALIFORNIA	
	SCALE 1" = 100' DATE 05 - 05 - 2023 PROJECT NO. G1006 - 52 - 05 SHEET 3 OF 6
FIGURE 3	

Pathed: 05/05/2023 8:38AM | By: ALVIN LADRILLON | File Location: W:\1_GEO\TECH\1000\1006-52-05\2023-05-05\G1006-52-05_Geo_Map_20.dwg

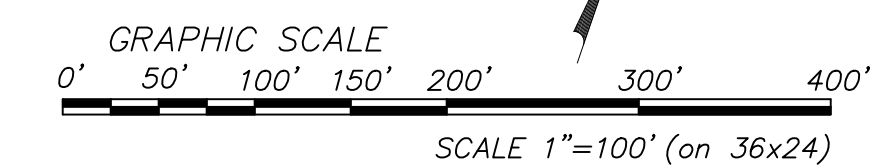
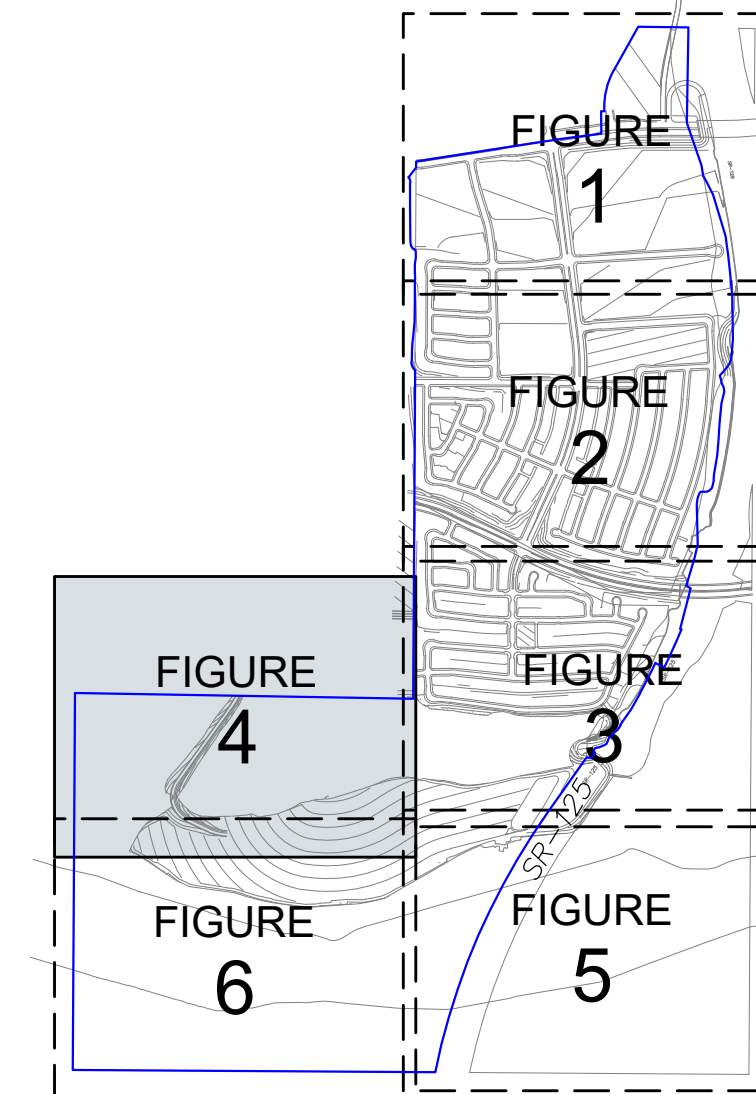
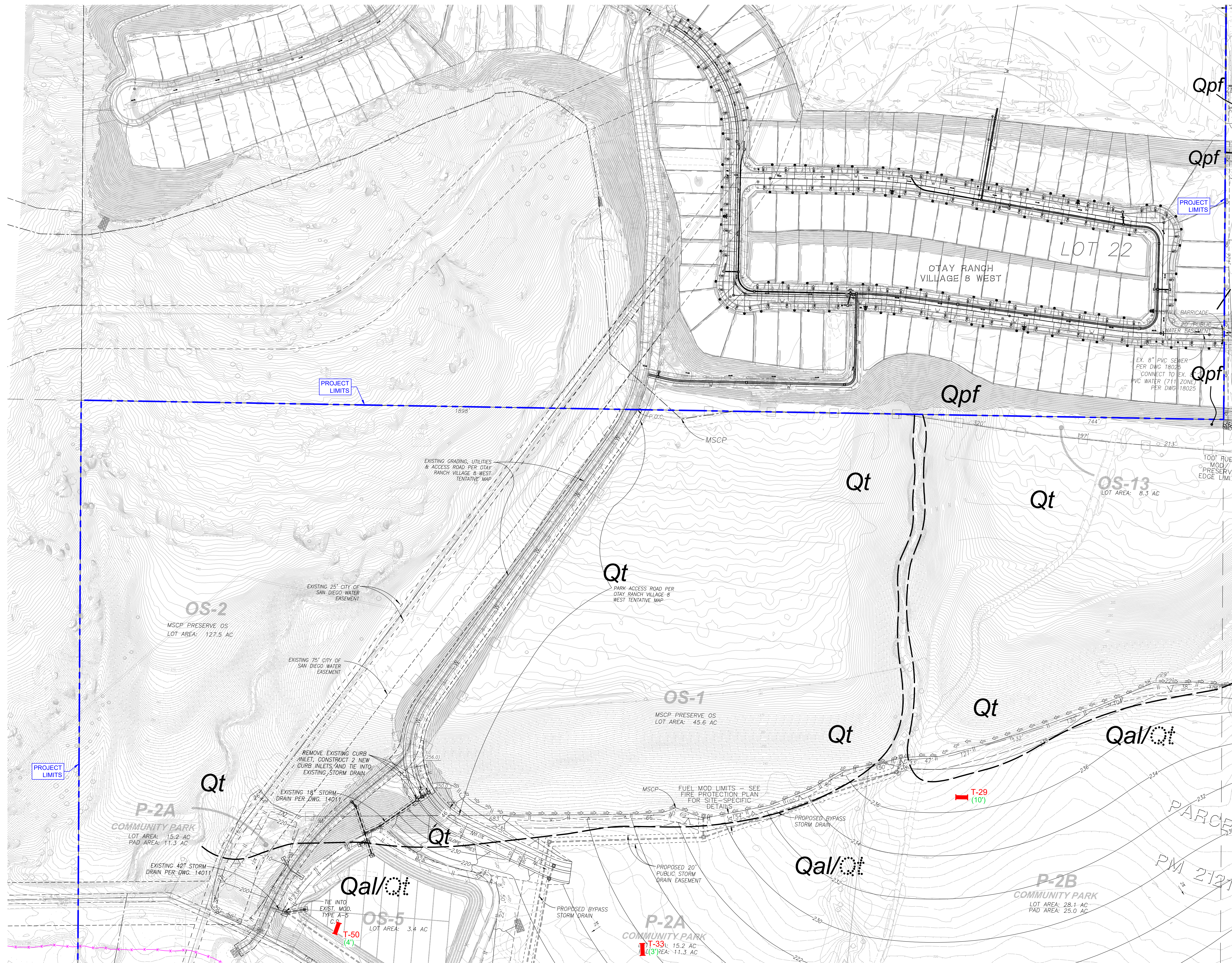

GEOCON LEGEND

- Qcf** COMPACTED FILL
- Qdf** UNDOCUMENTED FILL
- Qpf** PREVIOUSLY PLACED FILL
- Qal** ALLUVIUM
- Qt** TERRACE DEPOSITS (Dotted Where Buried)
- To** OTAY FORMATION (Dotted Where Buried)
- To_g** OTAY FORMATION (Gritstone) (Dotted Where Buried)
- ~** APPROX. LOCATION OF GEOLOGIC CONTACT (Dotted Where Buried, Queried Where Uncertain)
- B-19** APPROX. LOCATION OF EXPLORATORY BORING
- T-57** APPROX. LOCATION OF EXPLORATORY TRENCH
- (3')** APPROX. DEPTH TO FORMATIONAL (In Feet)
- H** APPROX. LOCATION OF GEOLOGIC CROSS SECTIONS
- W-30** REQUIRED WIDTH OF BUTTRESS (In Feet)
- APPROX. LOCATION OF EXISTING 8-INCH SOIL-ROCK FILL SUBDRAIN
- APPROX. LOCATION OF EXISTING 6-INCH SOIL-ROCK FILL SUBDRAIN
- APPROX. LOCATION OF PROPOSED 8-INCH CANYON SUBDRAIN
- APPROX. LOCATION OF PROPOSED 6-INCH CANYON SUBDRAIN
- APPROX. LOCATION OF EXISTING 8-INCH SUBDRAIN (Geotechnics, 2005)
- 360** APPROX. ELEVATION OF SUBDRAIN (In Feet, MSL)
- ?** APPROX. LOCATION OF OBSERVED BENTONITE CLAYSTONE BED (Queried Where Uncertain)
- 423** APPROX. ELEVATION OF OBSERVED BENTONITE CLAYSTONE BED (In Feet, MSL)
- 344** APPROX. ELEVATION OF BASE OF FILL (In Feet, MSL)

GEOLOGIC MAP

OTAY RANCH - VILLAGE 8 EAST
CHULA VISTA, CALIFORNIA

GEOCON INCORPORATED GEO TECHNICAL ■ ENVIRONMENTAL ■ MATERIALS 6940 FLANDERS DRIVE - SAN DIEGO, CALIFORNIA 92121-2974 PHONE 658-558-6900 - FAX 658-558-6159	SCALE 1" = 100' PROJECT NO. G1006 - 52 - 05 SHEET 4 OF 6	DATE 05 - 05 - 2023 FIGURE 4
---	--	---------------------------------

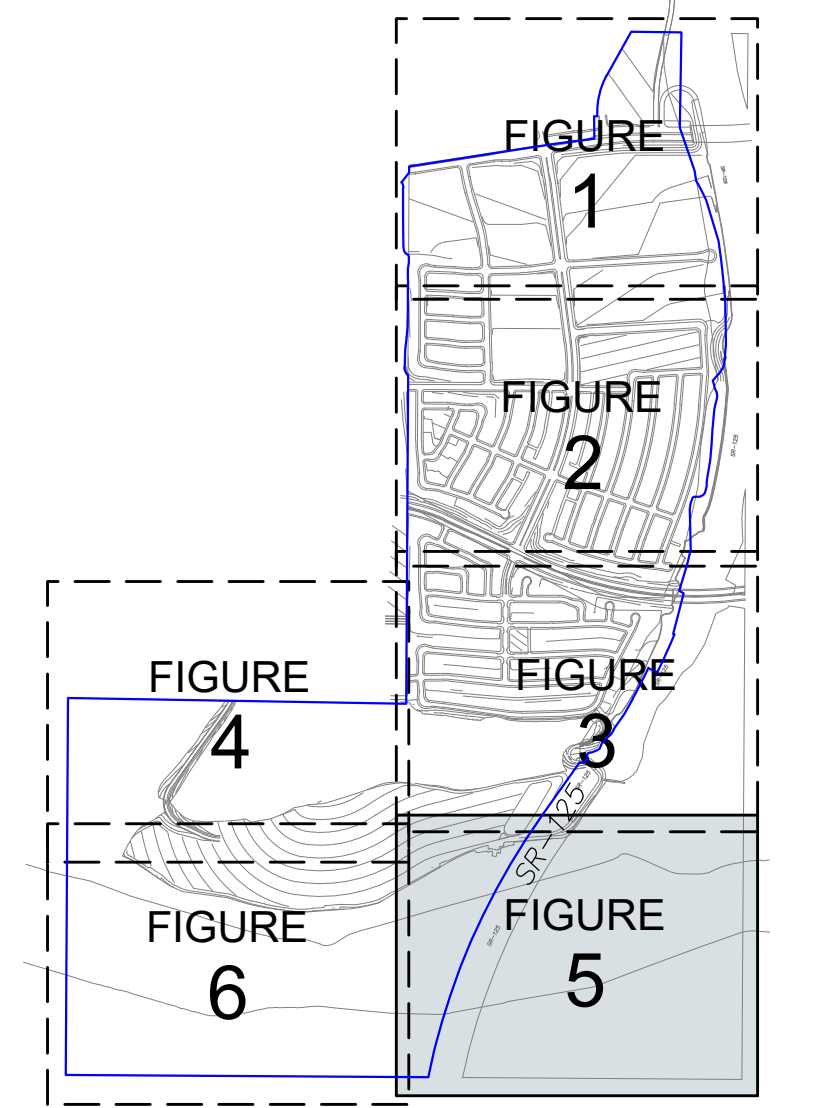
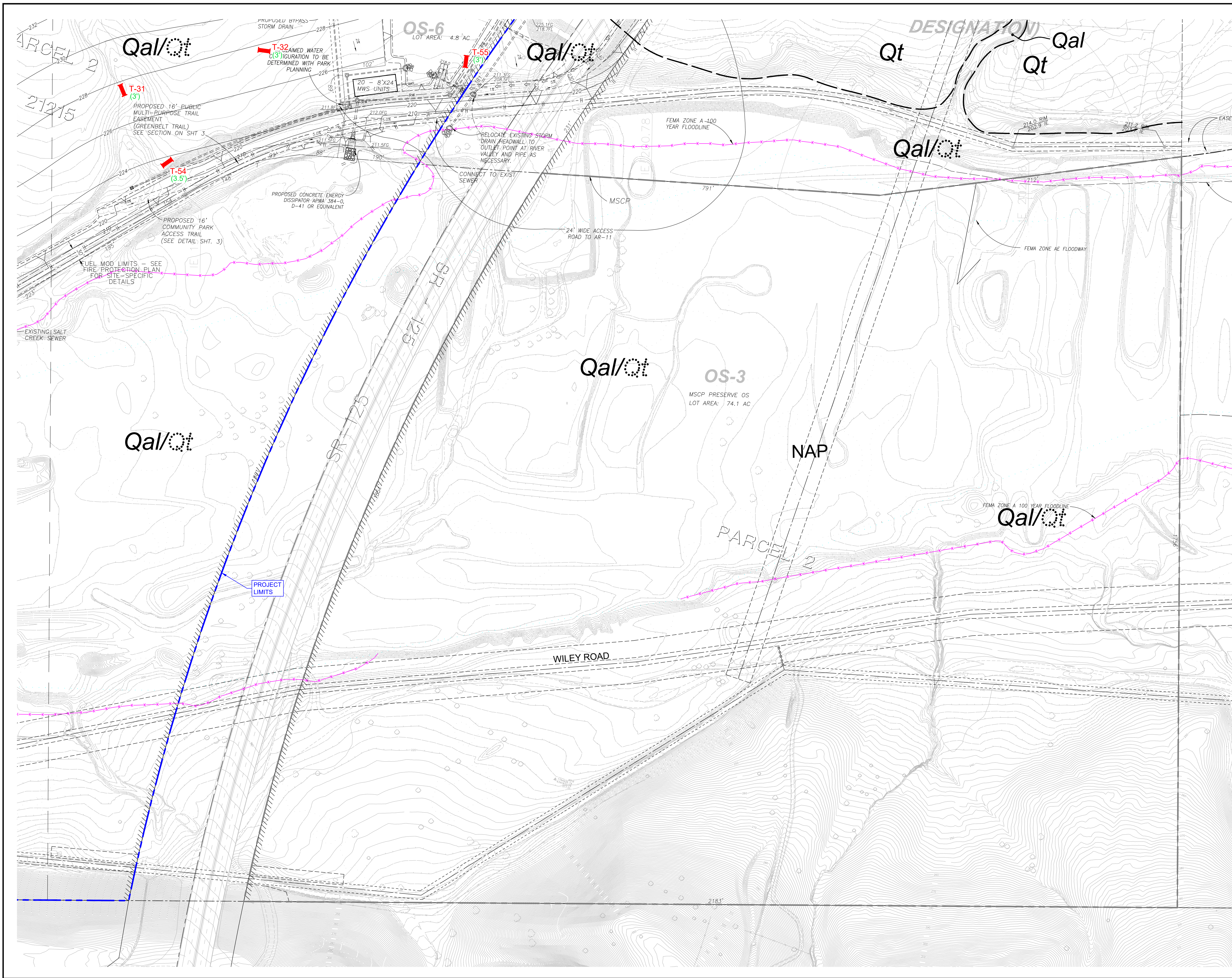

INDEX MAP
NO SCALE

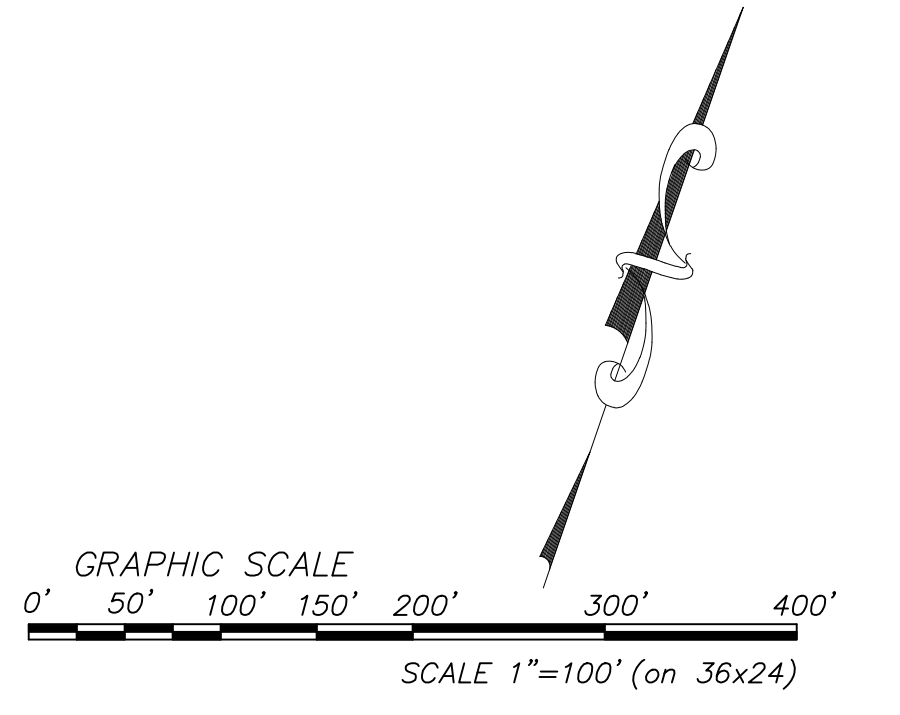

GEOCON LEGEND

- Qcf** COMPACTED FILL
- Qudf** UNDOCUMENTED FILL
- Qpf** PREVIOUSLY PLACED FILL
- Qal** ALLUVIUM
- Qt** TERRACE DEPOSITS (Dotted Where Buried)
- To** OTAY FORMATION (Dotted Where Buried)
- To_g** OTAY FORMATION (Griststone) (Dotted Where Buried)
- ~** APPROX. LOCATION OF GEOLOGIC CONTACT (Dotted Where Buried, Queried Where Uncertain)
- B-19** APPROX. LOCATION OF EXPLORATORY BORING
- T-57** APPROX. LOCATION OF EXPLORATORY TRENCH
- (3')** APPROX. DEPTH TO FORMATIONAL (In Feet)
- H** APPROX. LOCATION OF GEOLOGIC CROSS SECTIONS
- [W=30]** REQUIRED WIDTH OF BUTTRESS (In Feet)
- APPROX. LOCATION OF EXISTING 8-INCH SOIL-ROCK FILL SUBDRAIN
- APPROX. LOCATION OF EXISTING 6-INCH SOIL-ROCK FILL SUBDRAIN
- APPROX. LOCATION OF PROPOSED 8-INCH CANYON SUBDRAIN
- APPROX. LOCATION OF PROPOSED 6-INCH CANYON SUBDRAIN
- APPROX. LOCATION OF EXISTING 8-INCH SUBDRAIN (Geotechnics, 2005)
- 350** APPROX. ELEVATION OF SUBDRAIN (In Feet, MSL)
- ?** APPROX. LOCATION OF OBSERVED BENTONITE CLAYSTONE BED (Queried Where Uncertain)
- 423** APPROX. ELEVATION OF OBSERVED BENTONITE CLAYSTONE BED (In Feet, MSL)
- 344** APPROX. ELEVATION OF BASE OF FILL (In Feet, MSL)

GEOLOGIC MAP
OTAY RANCH - VILLAGE 8 EAST
CHULA VISTA, CALIFORNIA

 <small>GEOCON INCORPORATED 6940 FLANDERS DRIVE - SAN DIEGO, CALIFORNIA 92121-2974 PHONE 619-538-6900 - FAX 619-538-6159</small>	SCALE 1" = 100'	DATE 05 - 05 - 2023
	PROJECT NO. G1006 - 52 - 05	FIGURE 5
SHEET 5 OF 6		

Plotted 05/05/2023 6:44AM | By ALVIN LADRILLON | File Location: W:\1_GEO\GEOLOGIC\1006\52-05\2023-05-05\G1006-52-05_Geo_Map_20.dwg

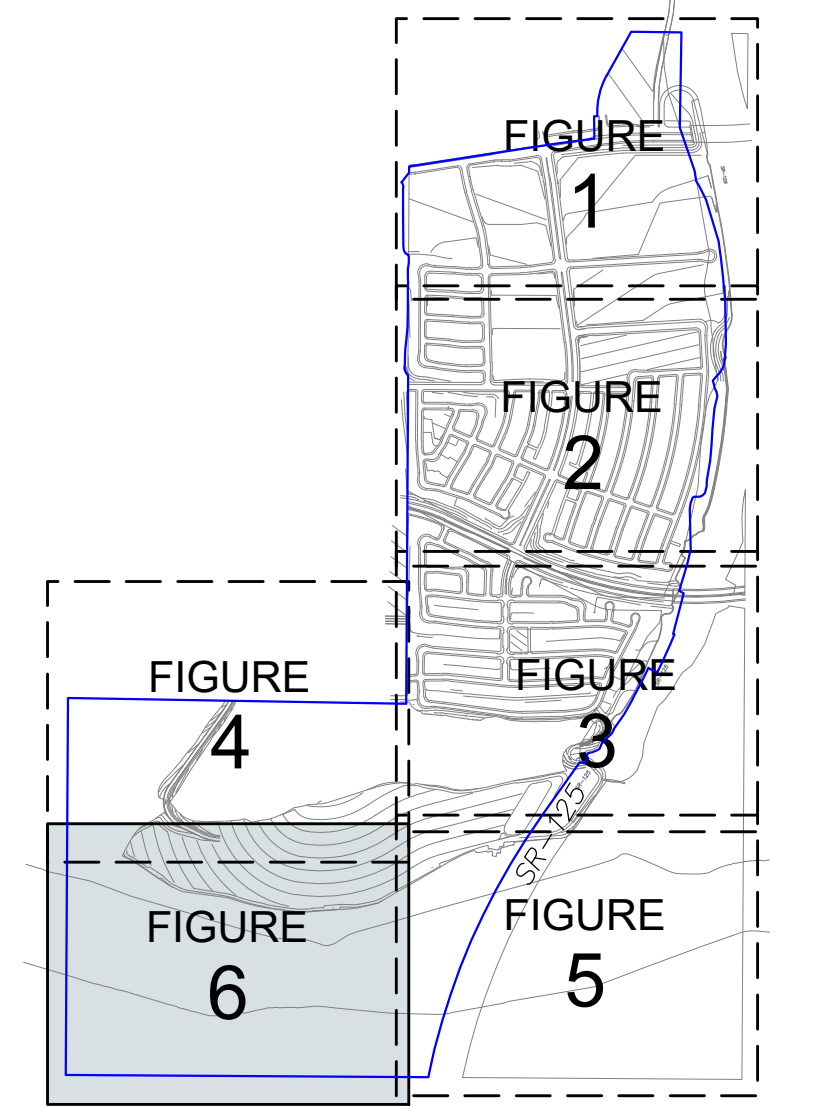
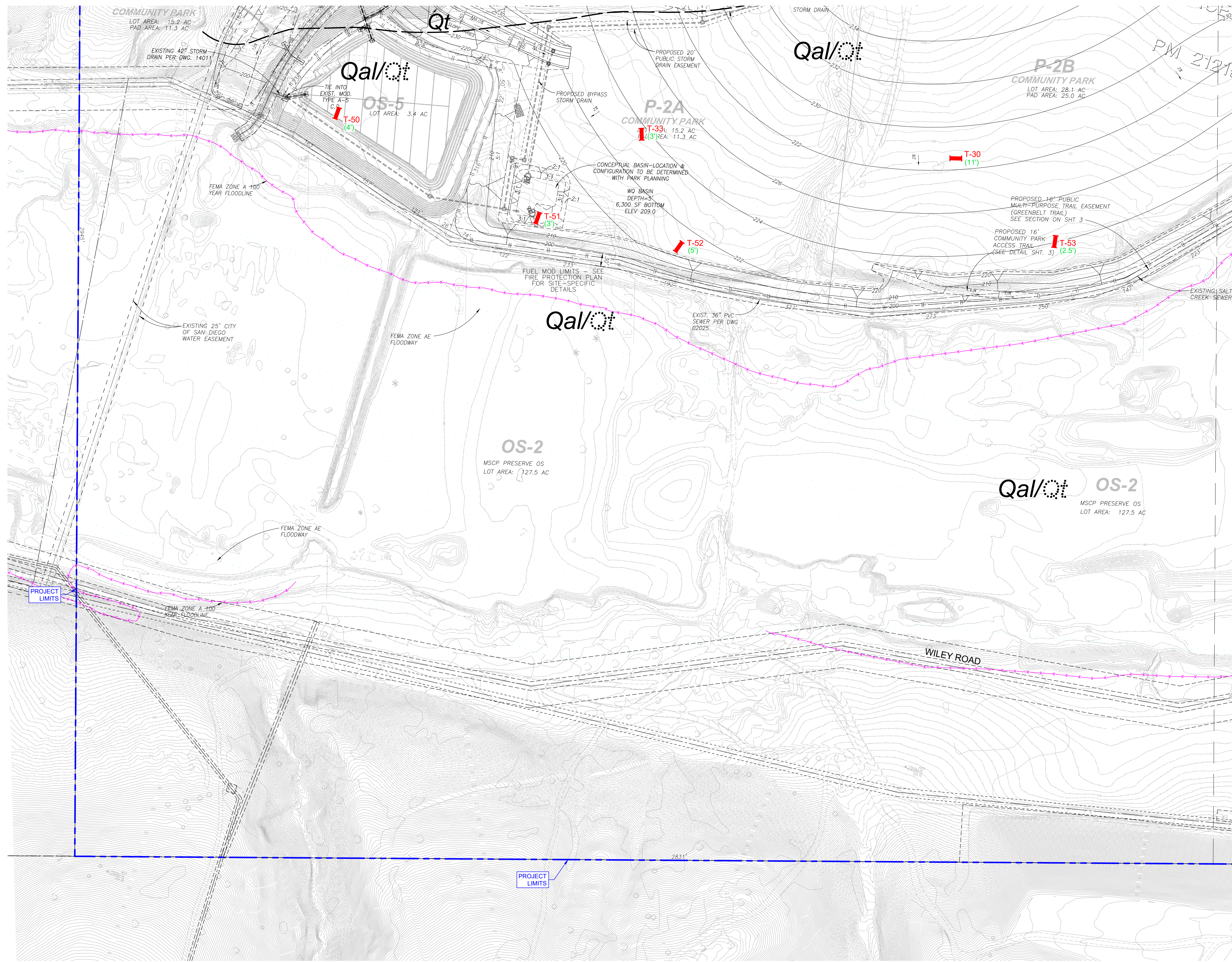

INDEX MAP
NO SCALE

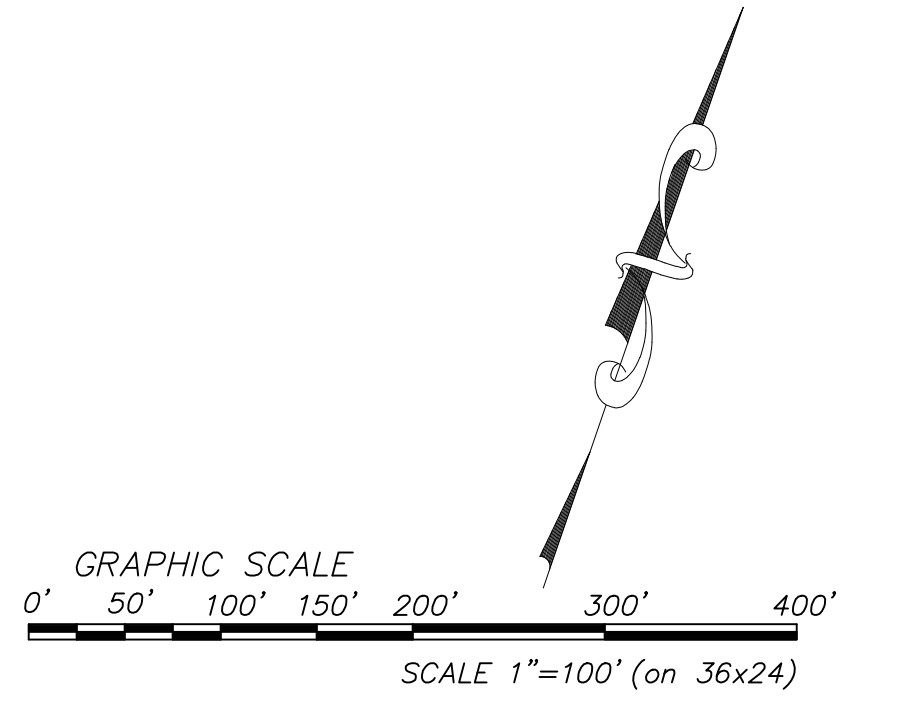

GEOCON LEGEND

- Qcf**COMPACTED FILL
- Qudf**UNDOCUMENTED FILL
- Qpf**PREVIOUSLY PLACED FILL
- Qal**ALLUVIUM
- Qt**TERRACE DEPOSITS (Dotted Where Buried)
- To**OTAY FORMATION (Dotted Where Buried)
- To_g**OTAY FORMATION (Griststone) (Dotted Where Buried)
- ~**APPROX. LOCATION OF GEOLOGIC CONTACT (Dotted Where Buried, Queried Where Uncertain)
- B-19**APPROX. LOCATION OF EXPLORATORY BORING
- T-57**APPROX. LOCATION OF EXPLORATORY TRENCH
- (3')**APPROX. DEPTH TO FORMATIONAL (In Feet)
- H**APPROX. LOCATION OF GEOLOGIC CROSS SECTIONS
- [W=30]**REQUIRED WIDTH OF BUTTRESS (In Feet)
-APPROX. LOCATION OF EXISTING 8-INCH SOIL-ROCK FILL SUBDRAIN
-APPROX. LOCATION OF EXISTING 6-INCH SOIL-ROCK FILL SUBDRAIN
-APPROX. LOCATION OF PROPOSED 8-INCH CANYON SUBDRAIN
-APPROX. LOCATION OF PROPOSED 6-INCH CANYON SUBDRAIN
-APPROX. LOCATION OF EXISTING 8-INCH SUBDRAIN (Geotechnics, 2005)
- 300**APPROX. ELEVATION OF SUBDRAIN (In Feet, MSL)
- ?**APPROX. LOCATION OF OBSERVED BENTONITE CLAYSTONE BED (Queried Where Uncertain)
- 423**APPROX. ELEVATION OF OBSERVED BENTONITE CLAYSTONE BED (In Feet, MSL)
- 344**APPROX. ELEVATION OF BASE OF FILL (In Feet, MSL)

GEOLOGIC MAP
OTAY RANCH - VILLAGE 8 EAST
CHULA VISTA, CALIFORNIA

GEOCON INCORPORATED GEOTECHNICAL ■ ENVIRONMENTAL ■ MATERIALS 6940 FLANDERS DRIVE - SAN DIEGO, CALIFORNIA 92121-2974 PHONE 658-558-6900 - FAX 658-558-6159	SCALE 1" = 100' PROJECT NO. G1006 - 52 - 05	DATE 05 - 05 - 2023 FIGURE 6
	SHEET 6 OF 6	

Plotted 05/05/2023 6:47AM | By ALVIN LADRILLONCO | File Location: W:\1_GEO\TECH\1000\G1006-52-05-2023-05-05\G1006-52-05_Geo_Map_20.dwg

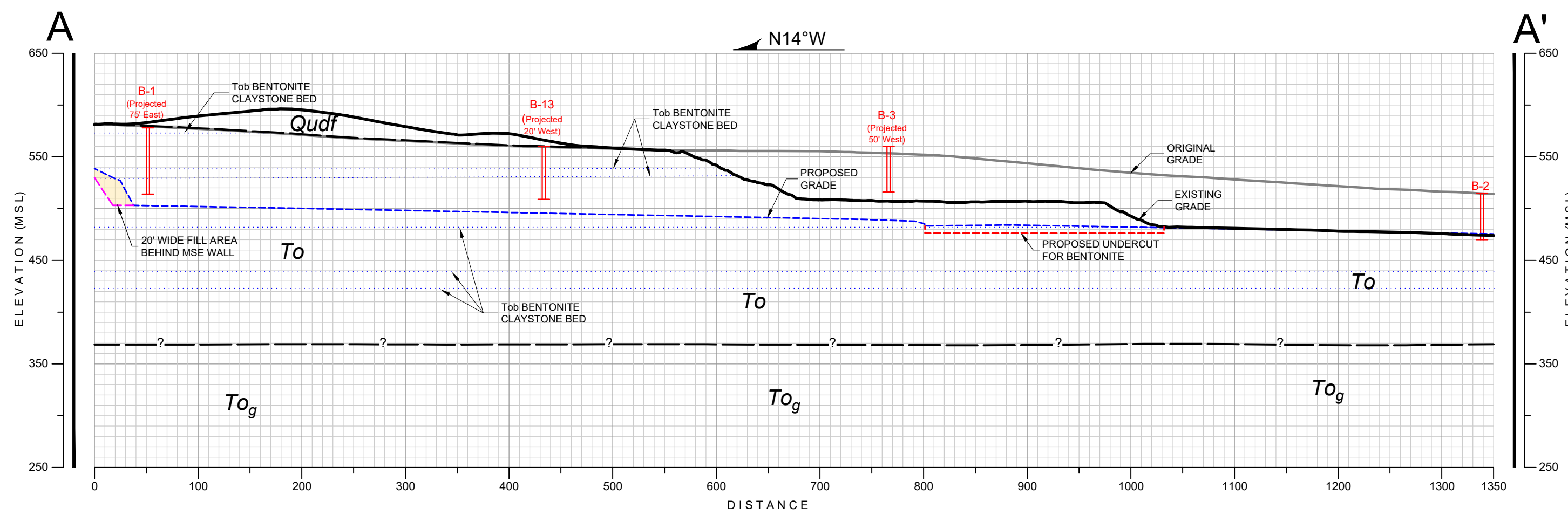

GEOLOGIC CROSS-SECTION A-A'
SCALE: 1" = 100' (Vert. = Horiz.)

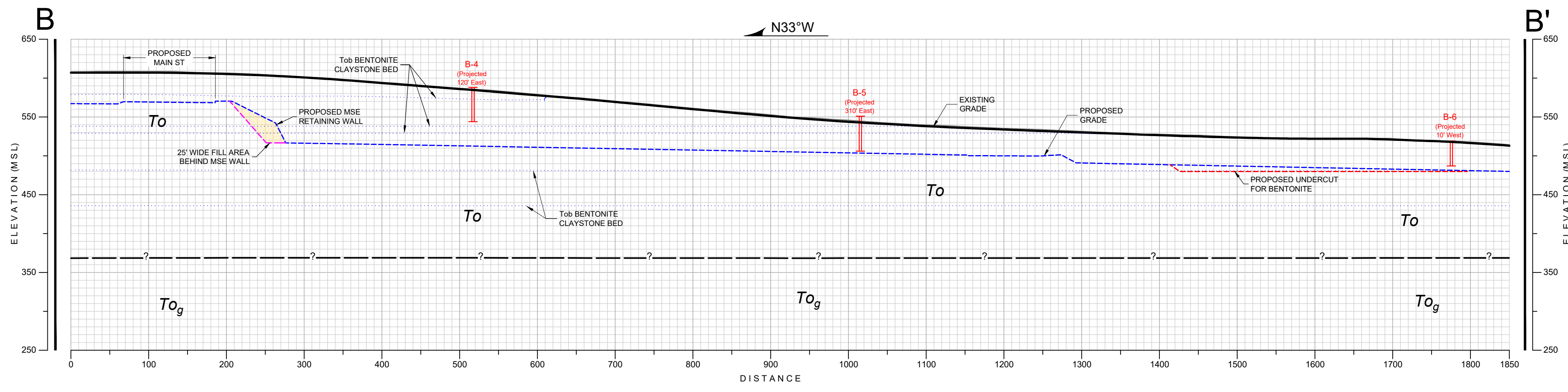

GEOLOGIC CROSS-SECTION B-B'
SCALE: 1" = 100' (Vert. = Horiz.)

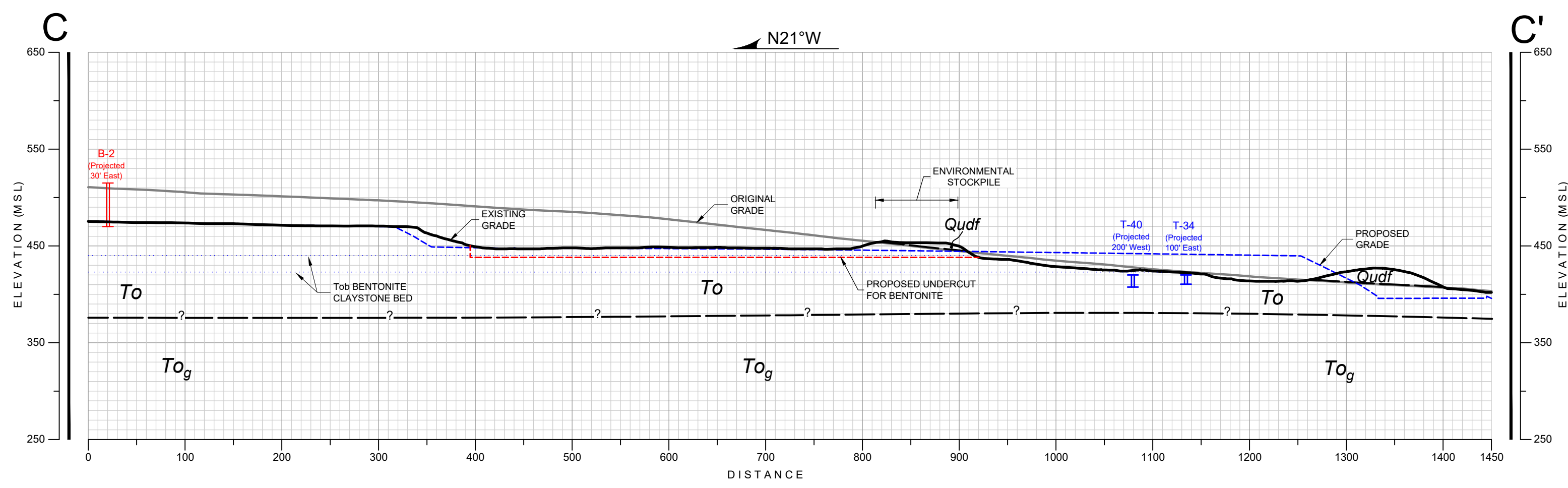

GEOLOGIC CROSS-SECTION C-C'
SCALE: 1" = 100' (Vert. = Horiz.)

- GEOCON LEGEND**
- Qal.....ALLUVIUM
 - To.....OTAY FORMATION
 - To_g.....OTAY FORMATION (Gritstone)
 -APPROX. LOCATION OF GEOLOGIC CONTACT (Queried Where Uncertain)
 - B-19.....APPROX. LOCATION OF EXPLORATORY BORING
 - B-41.....APPROX. LOCATION OF EXPLORATORY TRENCH

GEOLOGIC CROSS SECTION							
OTAY RANCH - VILLAGE 8 EAST CHULA VISTA, CALIFORNIA							
GEOCON INCORPORATED GEO TECHNICAL ■ ENVIRONMENTAL ■ MATERIALS 6940 FLANDERS DRIVE - SAN DIEGO, CALIFORNIA 92121 - 2974 PHONE 658-558-6900 - FAX 658-558-6159	<table border="1"> <tr> <td>SCALE 1" = 100'</td> <td>DATE 05 - 05 - 2023</td> </tr> <tr> <td>PROJECT NO. G1006 - 52 - 05</td> <td>FIGURE 7</td> </tr> <tr> <td>SHEET 1 OF 2</td> <td></td> </tr> </table>	SCALE 1" = 100'	DATE 05 - 05 - 2023	PROJECT NO. G1006 - 52 - 05	FIGURE 7	SHEET 1 OF 2	
SCALE 1" = 100'	DATE 05 - 05 - 2023						
PROJECT NO. G1006 - 52 - 05	FIGURE 7						
SHEET 1 OF 2							

Plotter: 05/05/2023 8:48AM | By: ALVIN LADRILLON | File Location: W:\1_GEO\TECH\1000\G1006-52-05\2023-05-05\G1006-52-05-XSection.20.dwg

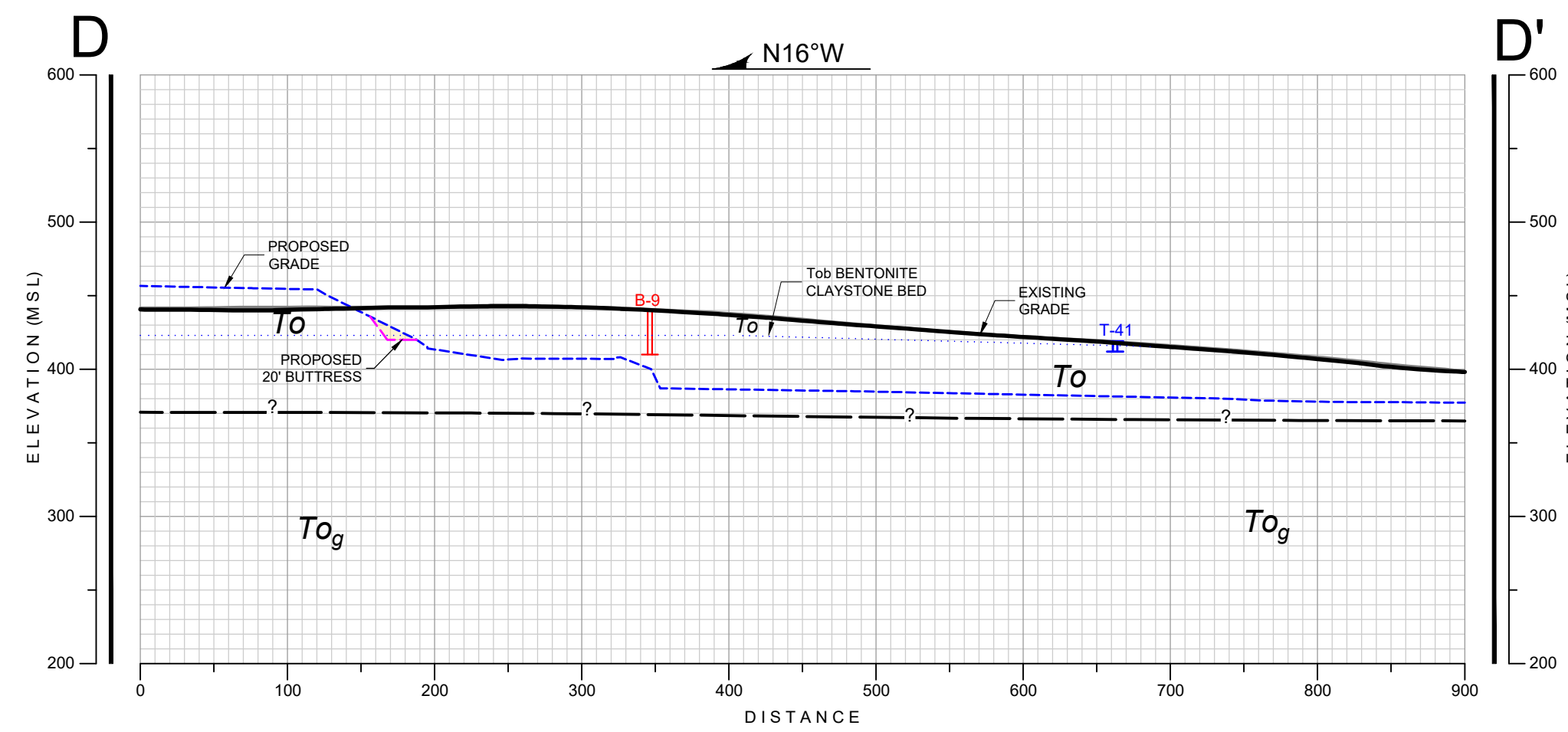

GEOLOGIC CROSS-SECTION D-D'
SCALE: 1" = 100' (Vert. = Horiz.)

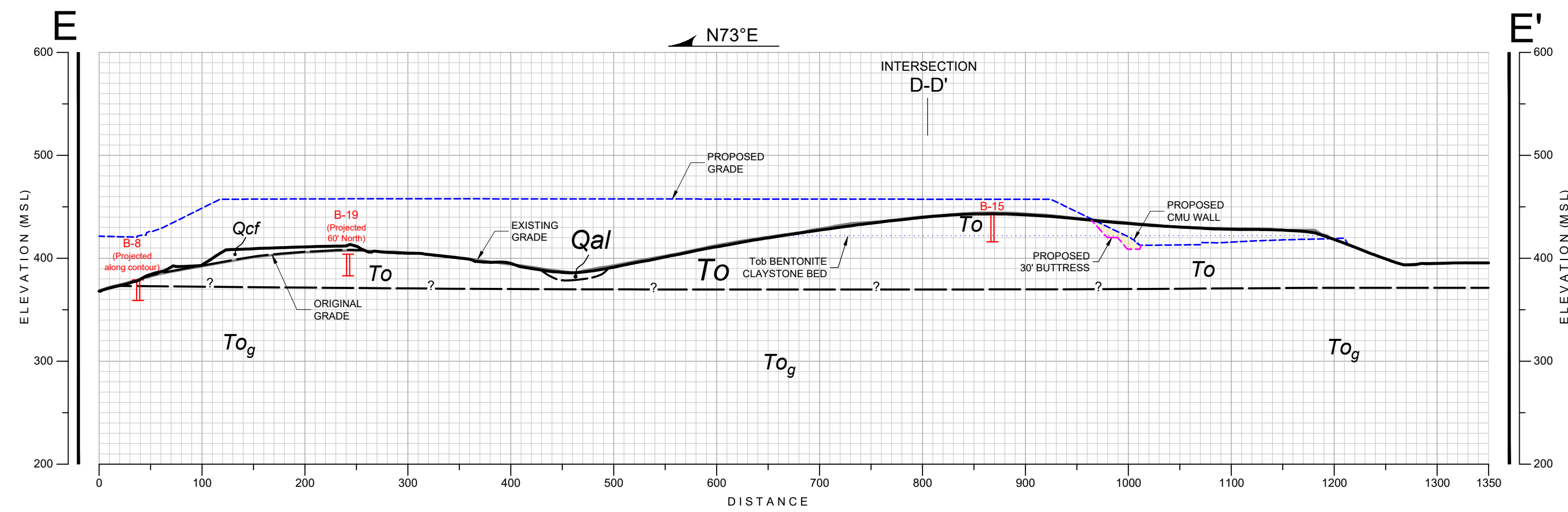

GEOLOGIC CROSS-SECTION E-E'
SCALE: 1" = 100' (Vert. = Horiz.)

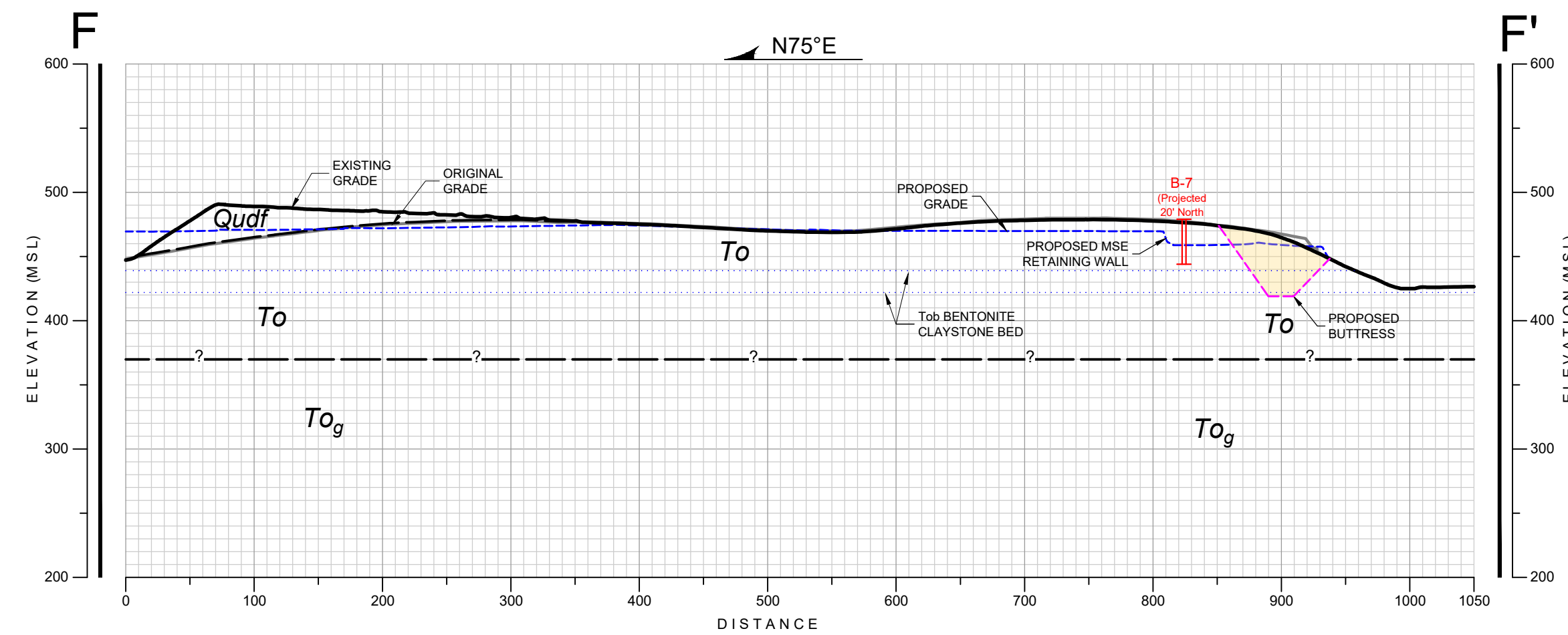

GEOLOGIC CROSS-SECTION F-F'
SCALE: 1" = 100' (Vert. = Horiz.)

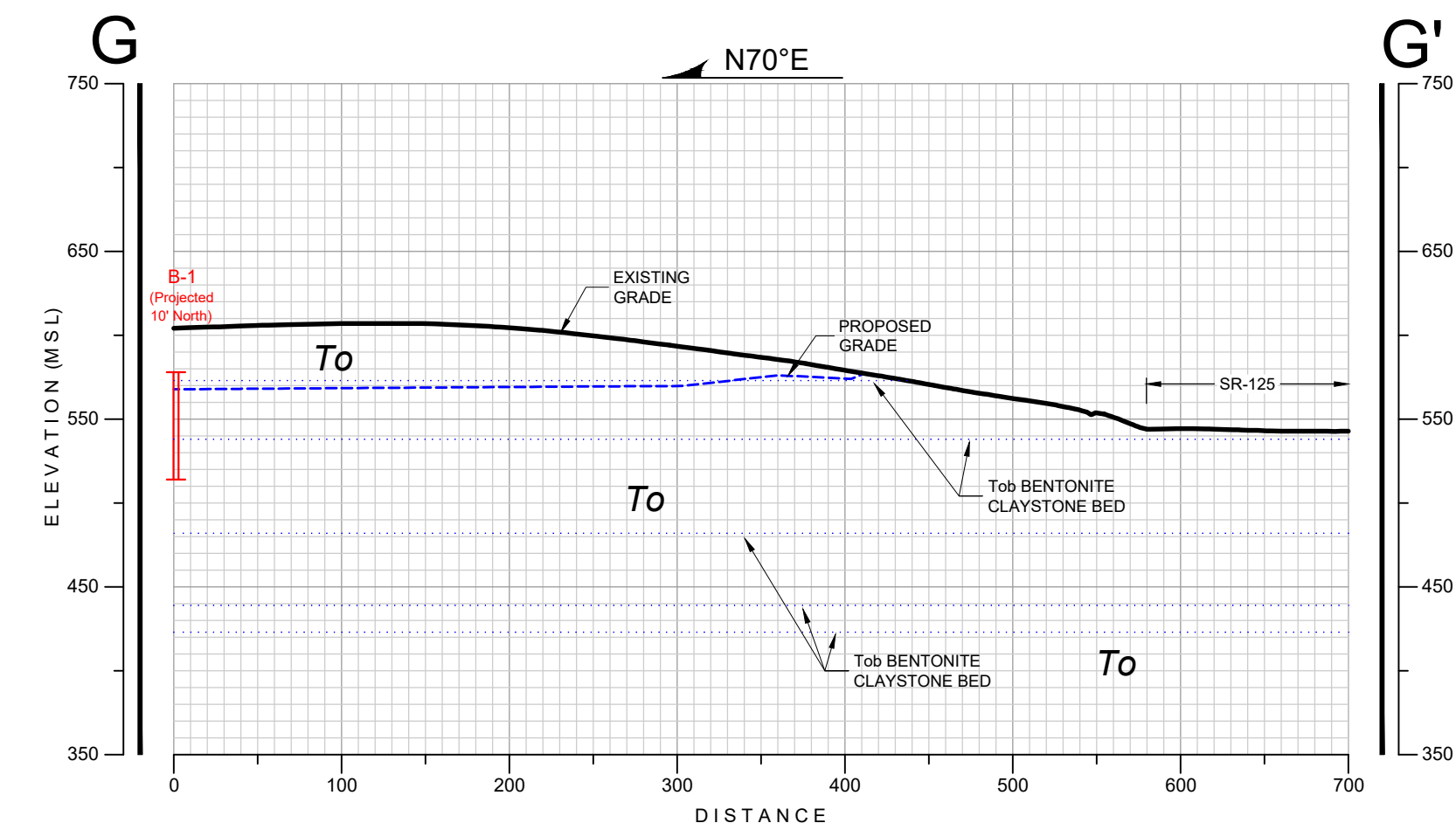

GEOLOGIC CROSS-SECTION G-G'
SCALE: 1" = 100' (Vert. = Horiz.)

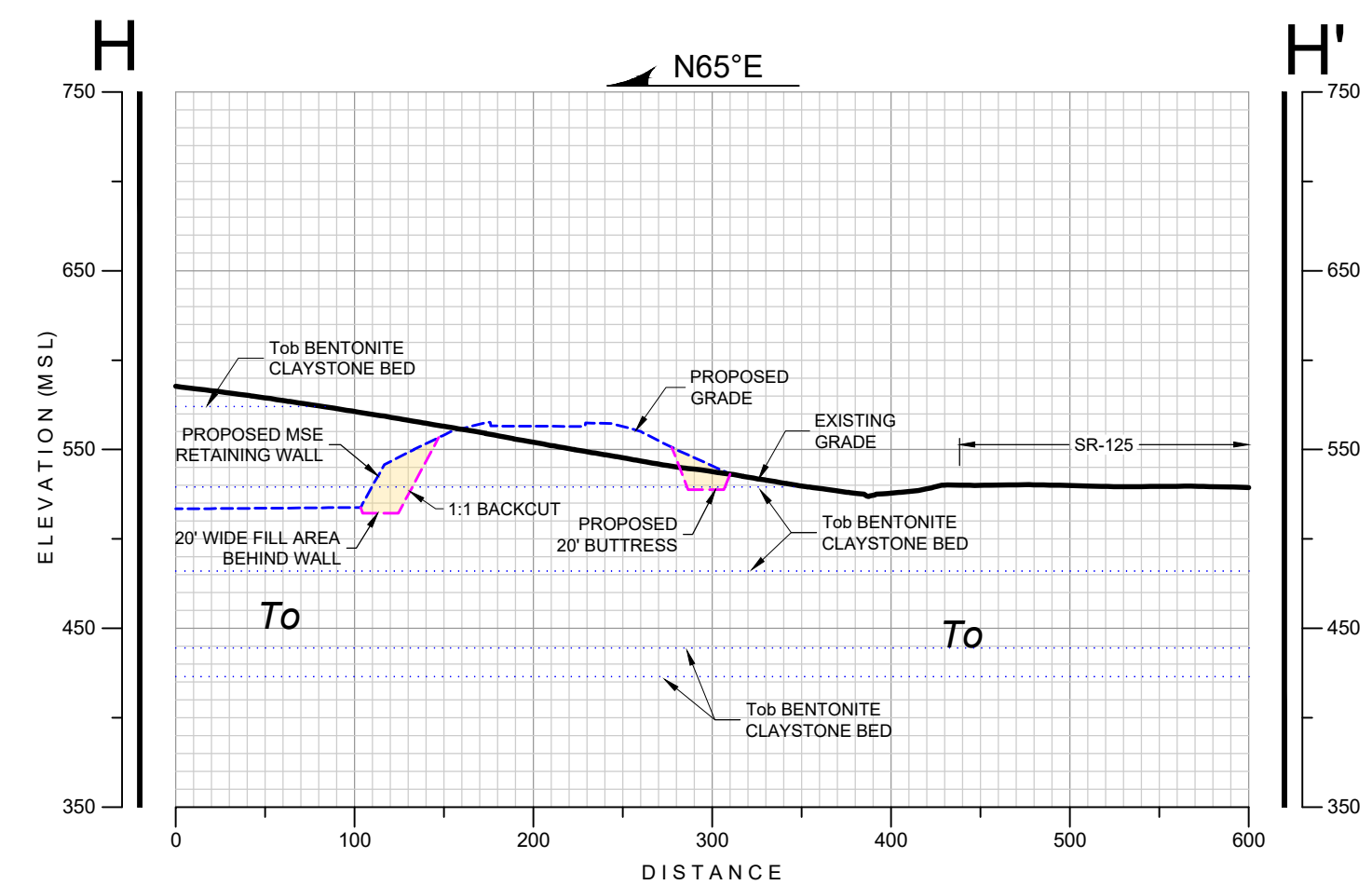

GEOLOGIC CROSS-SECTION H-H'
SCALE: 1" = 100' (Vert. = Horiz.)

- GEOCON LEGEND**
- Qal ALLUVIUM
 - To OTAY FORMATION
 - To_g OTAY FORMATION (Gritstone)
 - APPROX. LOCATION OF GEOLOGIC CONTACT (Queried Where Uncertain)
 - B-13 APPROX. LOCATION OF EXPLORATORY BORING
 - T-41 APPROX. LOCATION OF EXPLORATORY TRENCH

GEOLOGIC CROSS SECTION
OTAY RANCH - VILLAGE 8 EAST
CHULA VISTA, CALIFORNIA

<p style="font-size: 8px; margin: 0;">GEOCON INCORPORATED 6940 FLANDERS DRIVE - SAN DIEGO, CALIFORNIA 92121-2974 PHONE 658-558-6900 - FAX 658-558-6159</p>	SCALE 1" = 100'	DATE 05 - 05 - 2023
	PROJECT NO. G1006 - 52 - 05	FIGURE 8
SHEET 2 OF 2		

Plotwed 05/05/2023 6:48AM | By ALVIN LADRILLONDO | File Location: W:\1_GEO\TECH\1000\G1006-52-05\2023-05-05\G1006-52-05-XSection.20.dwg

APPENDIX

A

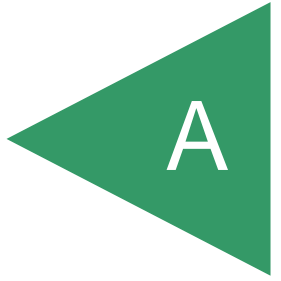

APPENDIX A

PREVIOUS BORING AND TRENCH LOGS

FOR







OTAY RANCH VILLAGE 8 WEST
CHULA VISTA, CALIFORNIA

PROJECT NO. G1006-52-05

DEPTH IN FEET	SAMPLE NO.	LITHOLOGY	GROUNDWATER	SOIL CLASS (USCS)	BORING B 1		PENETRATION RESISTANCE (BLOWS/FT.)	DRY DENSITY (P.C.F.)	MOISTURE CONTENT (%)
					ELEV. (MSL.) <u>571'</u>	DATE COMPLETED <u>02-21-2012</u>			
					EQUIPMENT <u>EZ BORE</u>		BY: <u>M. ERTWINE</u>		
MATERIAL DESCRIPTION									
0				SC	TOPSOIL Medium dense, moist, brown, Sandy CLAY; trace rootlets				
2									
4	B1-1			ML	OTAY FORMATION (To) Hard, moist, gray, Sandy SILTSTONE; blocky texture; some carbonates				
6									
8									
10	B1-2			SM	Very dense, damp, gray, Silty, fine-grained SANDSTONE; moderately cemented	5	115.8	13.3	
12									
14				CL/SM	Hard to dense, damp, olive brown, Sandy CLAYSTONE; interlayered with dense, Silty SANDSTONE				
16									
18									
20	B1-3			SM	-Becomes increasingly fine-grained at 19 feet Very dense, damp, grayish brown, Silty, fine-grained SANDSTONE, moderately cemented	5	110.1	13.6	
22									
24									
26									
28					-Subtle gradational change to claystone				

Figure A-1,
Log of Boring B 1, Page 1 of 3

G1006-11-05.GPJ

SAMPLE SYMBOLS			
	... SAMPLING UNSUCCESSFUL		... STANDARD PENETRATION TEST
	... DISTURBED OR BAG SAMPLE		... DRIVE SAMPLE (UNDISTURBED)
			... CHUNK SAMPLE
			... WATER TABLE OR  ... SEEPAGE

NOTE: THE LOG OF SUBSURFACE CONDITIONS SHOWN HEREON APPLIES ONLY AT THE SPECIFIC BORING OR TRENCH LOCATION AND AT THE DATE INDICATED. IT IS NOT WARRANTED TO BE REPRESENTATIVE OF SUBSURFACE CONDITIONS AT OTHER LOCATIONS AND TIMES.

DEPTH IN FEET	SAMPLE NO.	LITHOLOGY	GROUNDWATER	SOIL CLASS (USCS)	BORING B 1		PENETRATION RESISTANCE (BLOWS/FT.)	DRY DENSITY (P.C.F.)	MOISTURE CONTENT (%)
					ELEV. (MSL.) <u>571'</u>	DATE COMPLETED <u>02-21-2012</u>			
					EQUIPMENT <u>EZ BORE</u> BY: <u>M. ERTWINE</u>				
					MATERIAL DESCRIPTION				
30	B1-4			CL	Very hard, brown, Sandy CLAYSTONE, about 3" thick N20°W, 3°SE		10	102.5	23.0
32					Very hard, damp, olive brown to gray, Sandy SILTSTONE; interlayered with fissile laminations of brown, Sandy CLAYSTONE				
					-Gradational contact				
34	B1-9			CH	Very hard, damp, pinkish to grayish brown, bentonitic CLAYSTONE;				
36				SM	N25°W, 5°SE; approximate 8" thick fractured and well developed				
38					Dense, dry, light gray to whitish, Silty, fine-grained SANDSTONE				
40	B1-5						6	93.1	31.5
42				CH	Very hard, damp, grayish brown, bentonite CLAYSTONE				
44				SM	Dense, dry, light gray to whitish, Silty, fine-grained SANDSTONE				
46					-Massive homogeneous, moderately cemented, undisturbed and intact				
48					-Trace angular gravels				
50	B1-6			SM	Very dense, damp, gray-brown, Silty SANDSTONE		10	111.1	13.9
52	B1-7				-Becomes interlayered, fine SANDSTONE to Sandy SILTSTONE				
54									
56				SM/ML					
58									

Figure A-1,
Log of Boring B 1, Page 2 of 3

G1006-11-05.GPJ

SAMPLE SYMBOLS		... SAMPLING UNSUCCESSFUL		... STANDARD PENETRATION TEST		... DRIVE SAMPLE (UNDISTURBED)
		... DISTURBED OR BAG SAMPLE		... CHUNK SAMPLE		... WATER TABLE OR ... SEEPAGE

NOTE: THE LOG OF SUBSURFACE CONDITIONS SHOWN HEREON APPLIES ONLY AT THE SPECIFIC BORING OR TRENCH LOCATION AND AT THE DATE INDICATED. IT IS NOT WARRANTED TO BE REPRESENTATIVE OF SUBSURFACE CONDITIONS AT OTHER LOCATIONS AND TIMES.







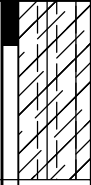

DEPTH IN FEET	SAMPLE NO.	LITHOLOGY	GROUNDWATER	SOIL CLASS (USCS)	BORING B 1		PENETRATION RESISTANCE (BLOWS/FT.)	DRY DENSITY (P.C.F.)	MOISTURE CONTENT (%)
					ELEV. (MSL.) <u>571'</u>	DATE COMPLETED <u>02-21-2012</u>			
					EQUIPMENT <u>EZ BORE</u> BY: <u>M. ERTWINE</u>				
					MATERIAL DESCRIPTION				
60	B1-8			CL-ML	Very hard, damp, olive brown, Sandy CLAYSTONE to Sandy SILTSTONE		12	89.1	34.2
62									
64					BORING TERMINATED AT 64 FEET No groundwater encountered				

Figure A-1,
Log of Boring B 1, Page 3 of 3

G1006-11-05.GPJ

SAMPLE SYMBOLS	 ... SAMPLING UNSUCCESSFUL	 ... STANDARD PENETRATION TEST	 ... DRIVE SAMPLE (UNDISTURBED)
	 ... DISTURBED OR BAG SAMPLE	 ... CHUNK SAMPLE	 ... WATER TABLE OR  ... SEEPAGE

NOTE: THE LOG OF SUBSURFACE CONDITIONS SHOWN HEREON APPLIES ONLY AT THE SPECIFIC BORING OR TRENCH LOCATION AND AT THE DATE INDICATED. IT IS NOT WARRANTED TO BE REPRESENTATIVE OF SUBSURFACE CONDITIONS AT OTHER LOCATIONS AND TIMES.

DEPTH IN FEET	SAMPLE NO.	LITHOLOGY	GROUNDWATER	SOIL CLASS (USCS)	BORING B 2		PENETRATION RESISTANCE (BLOWS/FT.)	DRY DENSITY (P.C.F.)	MOISTURE CONTENT (%)
					ELEV. (MSL.) <u>515'</u>	DATE COMPLETED <u>02-21-2012</u>			
					EQUIPMENT <u>EZ BORE</u> BY: <u>M. ERTWINE</u>				
MATERIAL DESCRIPTION									
0				SC	TOPSOIL Loose, moist, dark brown, Clayey SAND; some carbonates				
2				SM	OTAY FORMATION (To) Medium dense, damp, light gray, Silty, fine to medium SANDSTONE; blocky texture; occasional angular clasts of well cemented sandstone; trace carbonates -Becomes dense at five feet				
10	B2-1			SM	Very dense, damp, light gray, Silty, fine-grained SANDSTONE; moderately cemented -Subtle gradational color change to reddish brown -Trace clay -Trace gravels to 20 feet	5	103.1	22.2	
18	B2-2								
20	B2-3			SM	-Sharp, near horizontal contact, N25°W, 5°SE Very dense, damp, light reddish brown to brown, Silty, fine-to medium grained SANDSTONE -Becomes very difficult excavation	7	110.9	16.4	
26				SM	Very dense, damp, dark gray, Silty, fine-grained SANDSTONE; well cemented -At 29 feet, 1" thick, trace clasts of bentonitic CLAYSTONE; non contiguous				

Figure A-2,
Log of Boring B 2, Page 1 of 2

G1006-11-05.GPJ

SAMPLE SYMBOLS		... SAMPLING UNSUCCESSFUL		... STANDARD PENETRATION TEST		... DRIVE SAMPLE (UNDISTURBED)
		... DISTURBED OR BAG SAMPLE		... CHUNK SAMPLE		... WATER TABLE OR ... SEEPAGE

NOTE: THE LOG OF SUBSURFACE CONDITIONS SHOWN HEREON APPLIES ONLY AT THE SPECIFIC BORING OR TRENCH LOCATION AND AT THE DATE INDICATED. IT IS NOT WARRANTED TO BE REPRESENTATIVE OF SUBSURFACE CONDITIONS AT OTHER LOCATIONS AND TIMES.

DEPTH IN FEET	SAMPLE NO.	LITHOLOGY	GROUNDWATER	SOIL CLASS (USCS)	BORING B 2		PENETRATION RESISTANCE (BLOWS/FT.)	DRY DENSITY (P.C.F.)	MOISTURE CONTENT (%)
					ELEV. (MSL.) <u>515'</u>	DATE COMPLETED <u>02-21-2012</u>			
					EQUIPMENT <u>EZ BORE</u> BY: <u>M. ERTWINE</u>				
					MATERIAL DESCRIPTION				
30	B2-4			SM	Very dense, dry, gray brown to whitish, Silty, fine-grained SANDSTONE; slightly cemented; trace biotite micas		10	108.9	16.9
32									
34									
36					-Becomes light reddish brown				
38				ML	Very hard, dry, light brown, Sandy SILTSTONE				
40	B2-5						10/7"	105.1	7.4
42					-Massive homogeneous				
44									
					BORING TERMINATED AT 45 FEET No groundwater encountered				

Figure A-2,
Log of Boring B 2, Page 2 of 2

G1006-11-05.GPJ

SAMPLE SYMBOLS	... SAMPLING UNSUCCESSFUL	... STANDARD PENETRATION TEST	... DRIVE SAMPLE (UNDISTURBED)
	... DISTURBED OR BAG SAMPLE	... CHUNK SAMPLE	... WATER TABLE OR ... SEEPAGE

NOTE: THE LOG OF SUBSURFACE CONDITIONS SHOWN HEREON APPLIES ONLY AT THE SPECIFIC BORING OR TRENCH LOCATION AND AT THE DATE INDICATED. IT IS NOT WARRANTED TO BE REPRESENTATIVE OF SUBSURFACE CONDITIONS AT OTHER LOCATIONS AND TIMES.

DEPTH IN FEET	SAMPLE NO.	LITHOLOGY	GROUNDWATER	SOIL CLASS (USCS)	BORING B 3		PENETRATION RESISTANCE (BLOWS/FT.)	DRY DENSITY (P.C.F.)	MOISTURE CONTENT (%)
					ELEV. (MSL.) 558'	DATE COMPLETED 02-22-2012			
					EQUIPMENT EZ BORE	BY: M. ERTWINE			
MATERIAL DESCRIPTION									
0				SC	TOPSOIL Loose, moist, brown, Clayey SAND				
2				SM	OTAY FORMATION (To) Dense, damp, light gray, Silty, fine -grained; some carbonates -Clay lense about 3" thick				
4				ML	Hard, damp, gray, Sandy SILTSTONE				
6				ML	Hard, damp, gray, Sandy SILTSTONE				
8				ML	Hard, damp, gray, Sandy SILTSTONE				
10	B3-1			SM	Very dense, damp, whitish to gray, Silty, fine-grained SANDSTONE; with interlayered Sandy SILTSTONE	5	115.9	8.6	
12				SM	Very dense, damp, whitish to gray, Silty, fine-grained SANDSTONE; with interlayered Sandy SILTSTONE				
14				ML	-Subtle gradational contact Hard, damp, gray, Sandy SILTSTONE				
16				ML	Hard, damp, gray, Sandy SILTSTONE				
18				ML	Hard, damp, gray, Sandy SILTSTONE				
20	B3-2			SM	-Becomes dark gray siltstone	6	104.1	19.9	
22				SM	-Becomes dark gray siltstone				
24	B3-3 B3-4			ML	-Faint bedding Very hard, damp, olive brown to brown, Sandy to Clayey SILTSTONE with noncontinuous clasts of CLAYSTONE	8	115.5	12.0	
26				ML	-Faint bedding Very hard, damp, olive brown to brown, Sandy to Clayey SILTSTONE with noncontinuous clasts of CLAYSTONE				
28	B3-5			SM	N70°W, 5°SE	1			

Figure A-3,
Log of Boring B 3, Page 1 of 2

G1006-11-05.GPJ

SAMPLE SYMBOLS		... SAMPLING UNSUCCESSFUL		... STANDARD PENETRATION TEST		... DRIVE SAMPLE (UNDISTURBED)
		... DISTURBED OR BAG SAMPLE		... CHUNK SAMPLE		... WATER TABLE OR ... SEEPAGE

NOTE: THE LOG OF SUBSURFACE CONDITIONS SHOWN HEREON APPLIES ONLY AT THE SPECIFIC BORING OR TRENCH LOCATION AND AT THE DATE INDICATED. IT IS NOT WARRANTED TO BE REPRESENTATIVE OF SUBSURFACE CONDITIONS AT OTHER LOCATIONS AND TIMES.

DEPTH IN FEET	SAMPLE NO.	LITHOLOGY	GROUNDWATER	SOIL CLASS (USCS)	BORING B 3		PENETRATION RESISTANCE (BLOWS/FT.)	DRY DENSITY (P.C.F.)	MOISTURE CONTENT (%)
					ELEV. (MSL.) <u>558'</u>	DATE COMPLETED <u>02-22-2012</u>			
					EQUIPMENT <u>EZ BORE</u> BY: <u>M. ERTWINE</u>				
MATERIAL DESCRIPTION									
30	B3-6			CH ML	Very dense, damp, brown, Silty, fine SANDSTONE Very hard, damp, light grayish brown, bentonitic CLAYSTONE; waxy texture bed approximately 3" thick -Near horizontal contact Very hard, damp, olive brown, Sandy SILTSTONE -Massive, homogeneous, intact				
32									
34									
36									
38									
40	B3-7			ML	Very hard, dry, light gray, Sandy SILTSTONE		10/8"	117.9	15.8
42									
44					BORING TERMINATED AT 44 FEET No groundwater encountered				

Figure A-3,
Log of Boring B 3, Page 2 of 2

G1006-11-05.GPJ

SAMPLE SYMBOLS		... SAMPLING UNSUCCESSFUL		... STANDARD PENETRATION TEST		... DRIVE SAMPLE (UNDISTURBED)
		... DISTURBED OR BAG SAMPLE		... CHUNK SAMPLE		... WATER TABLE OR ... SEEPAGE

NOTE: THE LOG OF SUBSURFACE CONDITIONS SHOWN HEREON APPLIES ONLY AT THE SPECIFIC BORING OR TRENCH LOCATION AND AT THE DATE INDICATED. IT IS NOT WARRANTED TO BE REPRESENTATIVE OF SUBSURFACE CONDITIONS AT OTHER LOCATIONS AND TIMES.

DEPTH IN FEET	SAMPLE NO.	LITHOLOGY	GROUNDWATER	SOIL CLASS (USCS)	BORING B 4		PENETRATION RESISTANCE (BLOWS/FT.)	DRY DENSITY (P.C.F.)	MOISTURE CONTENT (%)
					ELEV. (MSL.) <u>588'</u>	DATE COMPLETED <u>02-22-2012</u>			
					EQUIPMENT <u>EZ BORE</u> BY: <u>M. ERTWINE</u>				
MATERIAL DESCRIPTION									
0				SC	TOPSOIL Medium dense, moist, dark brown, Clayey SAND				
2									
4				SM	OTAY FORMATION (To) Dense, moist, gray brown, Silty, fine-grained SANDSTONE; blocky texture with trace carbonates				
6									
8									
10	B4-1			SM	Dense, dry, gray, Silty, fine-grained SANDSTONE; micaceous	5	111.4	17.9	
12									
14				CH	Very hard, olive, bentonitic CLAYSTONE, 6-inches thick, highly weathered				
16				SM	Very dense, damp, light grayish brown, Silty, fine-grained SANDSTONE; moderately to locally strongly cemented				
18									
20	B4-2					8/10"			
22									
24									
26									
28				CL	Hard, damp, brown, Sandy CLAYSTONE; 1' thick				
				ML	Very hard, damp, dark gray, Sandy SILTSTONE				

Figure A-4,
Log of Boring B 4, Page 1 of 2

G1006-11-05.GPJ

SAMPLE SYMBOLS		... SAMPLING UNSUCCESSFUL		... STANDARD PENETRATION TEST		... DRIVE SAMPLE (UNDISTURBED)
		... DISTURBED OR BAG SAMPLE		... CHUNK SAMPLE		... WATER TABLE OR ... SEEPAGE

NOTE: THE LOG OF SUBSURFACE CONDITIONS SHOWN HEREON APPLIES ONLY AT THE SPECIFIC BORING OR TRENCH LOCATION AND AT THE DATE INDICATED. IT IS NOT WARRANTED TO BE REPRESENTATIVE OF SUBSURFACE CONDITIONS AT OTHER LOCATIONS AND TIMES.







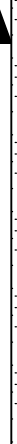

DEPTH IN FEET	SAMPLE NO.	LITHOLOGY	GROUNDWATER	SOIL CLASS (USCS)	BORING B 4		PENETRATION RESISTANCE (BLOWS/FT.)	DRY DENSITY (P.C.F.)	MOISTURE CONTENT (%)
					ELEV. (MSL.) <u>588'</u>	DATE COMPLETED <u>02-22-2012</u>			
					EQUIPMENT <u>EZ BORE</u> BY: <u>M. ERTWINE</u>				
MATERIAL DESCRIPTION									
30	B4-3			ML	-Very difficult drilling, auger attached to past 30 feet, sampling not practical				
32									
34									
36					-Massive and intact				
38									
40	B4-4			CL-ML	Very hard, olive gray, Silty CLAYSTONE to Clayey SILTSTONE; trace clasts of reworked claystone embedded with matrix			105.3	24.1
42									
44					BORING TERMINATED AT 44 FEET No groundwater encountered				

Figure A-4,
Log of Boring B 4, Page 2 of 2

G1006-11-05.GPJ

SAMPLE SYMBOLS		... SAMPLING UNSUCCESSFUL		... STANDARD PENETRATION TEST		... DRIVE SAMPLE (UNDISTURBED)
		... DISTURBED OR BAG SAMPLE		... CHUNK SAMPLE		... WATER TABLE OR  ... SEEPAGE

NOTE: THE LOG OF SUBSURFACE CONDITIONS SHOWN HEREON APPLIES ONLY AT THE SPECIFIC BORING OR TRENCH LOCATION AND AT THE DATE INDICATED. IT IS NOT WARRANTED TO BE REPRESENTATIVE OF SUBSURFACE CONDITIONS AT OTHER LOCATIONS AND TIMES.

DEPTH IN FEET	SAMPLE NO.	LITHOLOGY	GROUNDWATER	SOIL CLASS (USCS)	BORING B 5		PENETRATION RESISTANCE (BLOWS/FT.)	DRY DENSITY (P.C.F.)	MOISTURE CONTENT (%)
					ELEV. (MSL.) <u>553'</u>	DATE COMPLETED <u>02-22-2012</u>			
					EQUIPMENT <u>EZ BORE</u>		BY: <u>M. ERTWINE</u>		
MATERIAL DESCRIPTION									
0				SC	TOPSOIL Loose, damp, brown, Clayey SAND; some rootlets				
2									
4				SM	OTAY FORMATION (To) Dense, damp, light gray, Silty, fine SANDSTONE, some carbonates				
6									
8									
10	B5-1			SM	Dense, damp, light gray, Silty, fine SANDSTONE; moderately cemented	5	108.2	17.4	
12									
14				CL/CH	-Gradational contact Very hard, olive brown, Silty CLAYSTONE; trace clasts of reworked bentonitic claystone within matrix				
16	B5-2								
18									
20	B5-3			SM/CH	-Gradational contact Very dense, damp, light gray, Silty, fine-grained SANDSTONE; trace clasts of reworked bentonitic claystone within matrix	7/10"	114.6	12.5	
22									
24									
26				SM	Very dense, damp, light grayish brown, Silty, fine-grained SANDSTONE				
28									

Figure A-5,
Log of Boring B 5, Page 1 of 2

G1006-11-05.GPJ

SAMPLE SYMBOLS		... SAMPLING UNSUCCESSFUL		... STANDARD PENETRATION TEST		... DRIVE SAMPLE (UNDISTURBED)
		... DISTURBED OR BAG SAMPLE		... CHUNK SAMPLE		... WATER TABLE OR ... SEEPAGE

NOTE: THE LOG OF SUBSURFACE CONDITIONS SHOWN HEREON APPLIES ONLY AT THE SPECIFIC BORING OR TRENCH LOCATION AND AT THE DATE INDICATED. IT IS NOT WARRANTED TO BE REPRESENTATIVE OF SUBSURFACE CONDITIONS AT OTHER LOCATIONS AND TIMES.

DEPTH IN FEET	SAMPLE NO.	LITHOLOGY	GROUNDWATER	SOIL CLASS (USCS)	BORING B 5		PENETRATION RESISTANCE (BLOWS/FT.)	DRY DENSITY (P.C.F.)	MOISTURE CONTENT (%)
					ELEV. (MSL.) <u>553'</u>	DATE COMPLETED <u>02-22-2012</u>			
					EQUIPMENT <u>EZ BORE</u> BY: <u>M. ERTWINE</u>				
MATERIAL DESCRIPTION									
30	B5-4			ML	Very hard, light olive gray, Sandy SILTSTONE		7	100.3	21.3
32					-Becomes interlayered with very dense, Silty, fine-grained SANDSTONE; faintly bedded				
34									
36						-Becomes interlayered, very dense, Silty, fine-grained SANDSTONE to very hard, Sandy SILTSTONE; faintly bedded			
38									
40	B5-5			ML	Very hard, damp, gray, Sandy SILTSTONE		10/8"	116.0	10.3
42									
44									
BORING TERMINATED AT 45 FEET No groundwater encountered									

Figure A-5,
Log of Boring B 5, Page 2 of 2

G1006-11-05.GPJ







SAMPLE SYMBOLS	... SAMPLING UNSUCCESSFUL	... STANDARD PENETRATION TEST	... DRIVE SAMPLE (UNDISTURBED)
	... DISTURBED OR BAG SAMPLE	... CHUNK SAMPLE	... WATER TABLE OR ... SEEPAGE

NOTE: THE LOG OF SUBSURFACE CONDITIONS SHOWN HEREON APPLIES ONLY AT THE SPECIFIC BORING OR TRENCH LOCATION AND AT THE DATE INDICATED. IT IS NOT WARRANTED TO BE REPRESENTATIVE OF SUBSURFACE CONDITIONS AT OTHER LOCATIONS AND TIMES.

DEPTH IN FEET	SAMPLE NO.	LITHOLOGY	GROUNDWATER	SOIL CLASS (USCS)	BORING B 6		PENETRATION RESISTANCE (BLOWS/FT.)	DRY DENSITY (P.C.F.)	MOISTURE CONTENT (%)
					ELEV. (MSL.) 519'	DATE COMPLETED 02-23-2012			
					EQUIPMENT EZ BORE		BY: M. ERTWINE		
MATERIAL DESCRIPTION									
0				SM	TOPSOIL Medium dense, moist, brown, Silty SAND				
2				SM	OTAY FORMATION (To) Medium dense, moist, light gray, Silty, fine-grained SANDSTONE; blocky texture, trace carbonate				
4									
6									
8					-Well cemented, sandstone layer 4-inch thick				
10	B6-2			ML	Hard, damp, dark gray, Sandy SILTSTONE		4	114.3	15.6
12									
14									
16					-Becomes interbedded, Sandy SILTSTONE and Silty SANDSTONE				
18				CL ML	Very hard, damp, olive brown, Sandy CLAYSTONE; approximately 8" thick Very hard to dense, gray to reddish gray brown, interbedded, Sandy SILTSTONE to Silty fine-grained SANDSTONE				
20	B6-2						6	114.3	18.6
22					-Massive and intact				
24									
26									
28					-Homogeneous to about 30 feet				

Figure A-6,
Log of Boring B 6, Page 1 of 2

G1006-11-05.GPJ

SAMPLE SYMBOLS		... SAMPLING UNSUCCESSFUL		... STANDARD PENETRATION TEST		... DRIVE SAMPLE (UNDISTURBED)
		... DISTURBED OR BAG SAMPLE		... CHUNK SAMPLE		... WATER TABLE OR  ... SEEPAGE

NOTE: THE LOG OF SUBSURFACE CONDITIONS SHOWN HEREON APPLIES ONLY AT THE SPECIFIC BORING OR TRENCH LOCATION AND AT THE DATE INDICATED. IT IS NOT WARRANTED TO BE REPRESENTATIVE OF SUBSURFACE CONDITIONS AT OTHER LOCATIONS AND TIMES.

DEPTH IN FEET	SAMPLE NO.	LITHOLOGY	GROUNDWATER	SOIL CLASS (USCS)	BORING B 6		PENETRATION RESISTANCE (BLOWS/FT.)	DRY DENSITY (P.C.F.)	MOISTURE CONTENT (%)
					ELEV. (MSL.) <u>519'</u>	DATE COMPLETED <u>02-23-2012</u>			
					EQUIPMENT <u>EZ BORE</u> BY: <u>M. ERTWINE</u>				
					MATERIAL DESCRIPTION				
30	B6-3			SM	Very dense, damp, light gray to yellowish brown, fine-to-medium grained SANDSTONE		10/8"	116.2	13.5
32					BORING TERMINATED AT 32 FEET No groundwater encountered				

Figure A-6,
Log of Boring B 6, Page 2 of 2

G1006-11-05.GPJ







SAMPLE SYMBOLS	... SAMPLING UNSUCCESSFUL	... STANDARD PENETRATION TEST	... DRIVE SAMPLE (UNDISTURBED)
	... DISTURBED OR BAG SAMPLE	... CHUNK SAMPLE	... WATER TABLE OR ... SEEPAGE

NOTE: THE LOG OF SUBSURFACE CONDITIONS SHOWN HEREON APPLIES ONLY AT THE SPECIFIC BORING OR TRENCH LOCATION AND AT THE DATE INDICATED. IT IS NOT WARRANTED TO BE REPRESENTATIVE OF SUBSURFACE CONDITIONS AT OTHER LOCATIONS AND TIMES.

DEPTH IN FEET	SAMPLE NO.	LITHOLOGY	GROUNDWATER	SOIL CLASS (USCS)	BORING B 7		PENETRATION RESISTANCE (BLOWS/FT.)	DRY DENSITY (P.C.F.)	MOISTURE CONTENT (%)
					ELEV. (MSL.) <u>479'</u>	DATE COMPLETED <u>02-23-2012</u>			
					EQUIPMENT <u>EZ BORE</u>		BY: <u>M. ERTWINE</u>		
MATERIAL DESCRIPTION									
0				SM	TOPSOIL Loose, moist, brown, Silty SAND				
2				SP	OTAY FORMATION (To) Medium dense, moist, gray, Silty, fine-grained SANDSTONE; some carbonates, blocky texture				
4									
6									
8									
10	B7-1			ML	Very hard, damp, light grayish brown, Sandy SILTSTONE		8/10"	105.2	8.7
12									
14									
16									
18				ML/CL	-Grades to Clayey SILTSTONE/Sandy CLAYSTONE from 19-20 feet				
20	B7-2			SM	Very dense, damp, gray, Silty, fine-grained SANDSTONE		6/10"	110.8	12.6
22									
24					-Clasts of well cemented sandstone				
26	B7-3								
28					-Concretion layer about 3-inch thick				

Figure A-7,
Log of Boring B 7, Page 1 of 2

G1006-11-05.GPJ







SAMPLE SYMBOLS	 ... SAMPLING UNSUCCESSFUL	 ... STANDARD PENETRATION TEST	 ... DRIVE SAMPLE (UNDISTURBED)
	 ... DISTURBED OR BAG SAMPLE	 ... CHUNK SAMPLE	 ... WATER TABLE OR  ... SEEPAGE

NOTE: THE LOG OF SUBSURFACE CONDITIONS SHOWN HEREON APPLIES ONLY AT THE SPECIFIC BORING OR TRENCH LOCATION AND AT THE DATE INDICATED. IT IS NOT WARRANTED TO BE REPRESENTATIVE OF SUBSURFACE CONDITIONS AT OTHER LOCATIONS AND TIMES.

DEPTH IN FEET	SAMPLE NO.	LITHOLOGY	GROUNDWATER	SOIL CLASS (USCS)	BORING B 7		PENETRATION RESISTANCE (BLOWS/FT.)	DRY DENSITY (P.C.F.)	MOISTURE CONTENT (%)
					ELEV. (MSL.) <u>479'</u>	DATE COMPLETED <u>02-23-2012</u>			
					EQUIPMENT <u>EZ BORE</u> BY: <u>M. ERTWINE</u>				
MATERIAL DESCRIPTION									
30	B7-4			SM	Very dense, damp, gray to reddish brown, Silty, fine-grained SANDSTONE		6/3"	115.9	13.4
32									
34									
					BORING TERMINATED AT 35 FEET No groundwater encountered				

**Figure A-7,
Log of Boring B 7, Page 2 of 2**

G1006-11-05.GPJ

SAMPLE SYMBOLS		... SAMPLING UNSUCCESSFUL		... STANDARD PENETRATION TEST		... DRIVE SAMPLE (UNDISTURBED)
		... DISTURBED OR BAG SAMPLE		... CHUNK SAMPLE		... WATER TABLE OR  ... SEEPAGE

NOTE: THE LOG OF SUBSURFACE CONDITIONS SHOWN HEREON APPLIES ONLY AT THE SPECIFIC BORING OR TRENCH LOCATION AND AT THE DATE INDICATED. IT IS NOT WARRANTED TO BE REPRESENTATIVE OF SUBSURFACE CONDITIONS AT OTHER LOCATIONS AND TIMES.

DEPTH IN FEET	SAMPLE NO.	LITHOLOGY	GROUNDWATER	SOIL CLASS (USCS)	BORING B 8		PENETRATION RESISTANCE (BLOWS/FT.)	DRY DENSITY (P.C.F.)	MOISTURE CONTENT (%)
					ELEV. (MSL.) <u>379'</u>	DATE COMPLETED <u>02-23-2012</u>			
					EQUIPMENT <u>EZ BORE</u>		BY: <u>M. ERTWINE</u>		
MATERIAL DESCRIPTION									
0						TOPSOIL Medium dense, moist, brown, Clayey SAND			
2				SM		OTAY FORMATION (To) Dense, moist, gray, Silty, fine to medium SANDSTONE			
4									
6						-Near horizontal contact			
8				SM		OTAY FORMATION (Tog) Very dense, damp, yellowish to gray brown, Silty, fine-to coarse SANDSTONE ("GRITSTONE"); generally well-graded and intact			
10	B8-1						8/10"	123.3	8.1
12									
14						-Massive and homogeneous, some fine gravel, sized clasts, intact			
16									
18						-Very difficult excavation			
20						-Sampling not practical			
					BORING TERMINATED AT 20 FEET No groundwater encountered				

Figure A-8,
Log of Boring B 8, Page 1 of 1

G1006-11-05.GPJ

SAMPLE SYMBOLS	... SAMPLING UNSUCCESSFUL	... STANDARD PENETRATION TEST	... DRIVE SAMPLE (UNDISTURBED)
	... DISTURBED OR BAG SAMPLE	... CHUNK SAMPLE	... WATER TABLE OR ... SEEPAGE

NOTE: THE LOG OF SUBSURFACE CONDITIONS SHOWN HEREON APPLIES ONLY AT THE SPECIFIC BORING OR TRENCH LOCATION AND AT THE DATE INDICATED. IT IS NOT WARRANTED TO BE REPRESENTATIVE OF SUBSURFACE CONDITIONS AT OTHER LOCATIONS AND TIMES.

DEPTH IN FEET	SAMPLE NO.	LITHOLOGY	GROUNDWATER	SOIL CLASS (USCS)	BORING B 9		PENETRATION RESISTANCE (BLOWS/FT.)	DRY DENSITY (P.C.F.)	MOISTURE CONTENT (%)
					ELEV. (MSL.) <u>440'</u>	DATE COMPLETED <u>02-24-2012</u>			
					EQUIPMENT <u>EZ BORE</u>		BY: <u>M. ERTWINE</u>		
MATERIAL DESCRIPTION									
0				SC	TOPSOIL Loose, moist, brown, Clayey SAND				
2				SM	OTAY FORMATION (To) Medium dense to dense, moist, gray, Silty SANDSTONE				
4									
6									
8				CL	Hard, dense, brown, Sandy CLAYSTONE				
10	B9-1			ML	Very hard, olive brown, Sandy SILTSTONE; trace clasts of claystone within matrix	6/10"	100.4	24.3	
12									
14				SM	Very dense, damp, gray, Silty SANDSTONE				
16				CL	Hard, moist, olive brown, Silty CLAYSTONE; N75°E, 5°SW				
18	B9-2			CH	Hard, damp, olive gray to pink and white, bentonitic CLAYSTONE; fractured and approximately 12" thick; well developed	6/10"	116.3	14.6	
20				SM	-Distinct and continuous bed of bentonite Very dense, damp, reddish brown to brown, Silty, fine-grained SANDSTONE				
22				SM	Very dense, dry, whitish gray, Silty, medium to coarse-grained SANDSTONE; some fine gravels and cobbles, massive and intact				
24									
26									
28					-Large auger attached -Very difficult excavation, practical refusal				

Figure A-9,
Log of Boring B 9, Page 1 of 2

G1006-11-05.GPJ

SAMPLE SYMBOLS		... SAMPLING UNSUCCESSFUL		... STANDARD PENETRATION TEST		... DRIVE SAMPLE (UNDISTURBED)
		... DISTURBED OR BAG SAMPLE		... CHUNK SAMPLE		... WATER TABLE OR ... SEEPAGE

NOTE: THE LOG OF SUBSURFACE CONDITIONS SHOWN HEREON APPLIES ONLY AT THE SPECIFIC BORING OR TRENCH LOCATION AND AT THE DATE INDICATED. IT IS NOT WARRANTED TO BE REPRESENTATIVE OF SUBSURFACE CONDITIONS AT OTHER LOCATIONS AND TIMES.

DEPTH IN FEET	SAMPLE NO.	LITHOLOGY	GROUNDWATER	SOIL CLASS (USCS)	BORING B 10		PENETRATION RESISTANCE (BLOWS/FT.)	DRY DENSITY (P.C.F.)	MOISTURE CONTENT (%)
					ELEV. (MSL.) <u>379'</u>	DATE COMPLETED <u>02-24-2012</u>			
					EQUIPMENT <u>EZ BORE</u>		BY: <u>M. ERTWINE</u>		
MATERIAL DESCRIPTION									
0				SC	TOPSOIL Loose, moist, dark brown, Clayey SAND				
2				SM	OTAY FORMATION (To) Very dense, reddish brown, Silty, fine-to coarse SAND; some gravels				
4									
6									
8					-Sharp horizontal contact OTAY FORMATION (Tog) Very dense, damp, grayish brown, Silty, medium-to coarse-grained SANDSTONE; ("GRITSTONE"); massive and intact				
10	B10-1			SM		8/8"			
12									
14									
16					-Trace subangular gravels, up to 2 -inches in maximum dimension				
18									
20	B10-2				-Massive, very dense, difficult excavation, practical refusal	8/8"	137.7	5.2	
22									
24					-Trace pockets of gravel, 2"-4" within matrix				
26									
28					-Very difficult drilling, sampling not practical				

Figure A-10,
Log of Boring B 10, Page 1 of 2

G1006-11-05.GPJ

SAMPLE SYMBOLS		... SAMPLING UNSUCCESSFUL		... STANDARD PENETRATION TEST		... DRIVE SAMPLE (UNDISTURBED)
		... DISTURBED OR BAG SAMPLE		... CHUNK SAMPLE		... WATER TABLE OR ... SEEPAGE

NOTE: THE LOG OF SUBSURFACE CONDITIONS SHOWN HEREON APPLIES ONLY AT THE SPECIFIC BORING OR TRENCH LOCATION AND AT THE DATE INDICATED. IT IS NOT WARRANTED TO BE REPRESENTATIVE OF SUBSURFACE CONDITIONS AT OTHER LOCATIONS AND TIMES.











DEPTH IN FEET	SAMPLE NO.	LITHOLOGY	GROUNDWATER	SOIL CLASS (USCS)	BORING B 11		PENETRATION RESISTANCE (BLOWS/FT.)	DRY DENSITY (P.C.F.)	MOISTURE CONTENT (%)
					ELEV. (MSL.) <u>354'</u>	DATE COMPLETED <u>02-24-2012</u>			
					EQUIPMENT <u>EZ BORE</u>	BY: <u>M. ERTWINE</u>			
MATERIAL DESCRIPTION									
0				SM	TOPSOIL Loose, moist, brown, Silty SAND				
2				SM	OTAY FORMATION (Tog) Dense, moist, gray to yellowish brown, Silty, fine-to-coarse SANDSTONE ("GRITSTONE") -Clasts of subangular gravel and cobble up to 4-inches in matrix dimension				
10	B11-1			SM	Very dense, dry, whitish gray, Silty, medium-to-coarse grained SANDSTONE; moderately cemented -Becomes well cemented, difficult excavation -Increased conglomerate (gravel, cobble) clasts metavolcanic rock -Massive, homogeneous		110.4	4.6	
					BORING TERMINATED AT 25 FEET No groundwater encountered				

Figure A-11,
Log of Boring B 11, Page 1 of 1

G1006-11-05.GPJ

SAMPLE SYMBOLS	 ... SAMPLING UNSUCCESSFUL	 ... STANDARD PENETRATION TEST	 ... DRIVE SAMPLE (UNDISTURBED)
	 ... DISTURBED OR BAG SAMPLE	 ... CHUNK SAMPLE	 ... WATER TABLE OR  ... SEEPAGE

NOTE: THE LOG OF SUBSURFACE CONDITIONS SHOWN HEREON APPLIES ONLY AT THE SPECIFIC BORING OR TRENCH LOCATION AND AT THE DATE INDICATED. IT IS NOT WARRANTED TO BE REPRESENTATIVE OF SUBSURFACE CONDITIONS AT OTHER LOCATIONS AND TIMES.







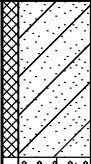
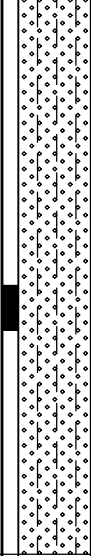

DEPTH IN FEET	SAMPLE NO.	LITHOLOGY	GROUNDWATER	SOIL CLASS (USCS)	BORING B 12		PENETRATION RESISTANCE (BLOWS/FT.)	DRY DENSITY (P.C.F.)	MOISTURE CONTENT (%)
					ELEV. (MSL.) <u>370'</u>	DATE COMPLETED <u>02-24-2012</u>			
					EQUIPMENT <u>EZ BORE</u> BY: <u>M. ERTWINE</u>				
					MATERIAL DESCRIPTION				
0	B12-1			CL	TOPSOIL Stiff, moist, dark brown, Sandy CLAY, trace organic -Rootlets and abundant carbonates at about 3.5 feet				
2									
4				SM	OTAY FORMATION (Tog) Very dense, dry, yellowish brown, Silty, medium-to-coarse SANDSTONE; ("GRITSTONE"), moderately cemented				
6									
8									
10	B12-2				8/8" 133.7 7.3				
12					-Gravel and cobble up to 2"-4", massive and intact				
14					-Very difficult excavation, practical refusal with auger attached				
16					BORING TERMINATED AT 16 FEET No groundwater encountered				

Figure A-12,
Log of Boring B 12, Page 1 of 1

G1006-11-05.GPJ

SAMPLE SYMBOLS	 ... SAMPLING UNSUCCESSFUL	 ... STANDARD PENETRATION TEST	 ... DRIVE SAMPLE (UNDISTURBED)
	 ... DISTURBED OR BAG SAMPLE	 ... CHUNK SAMPLE	 ... WATER TABLE OR  ... SEEPAGE

NOTE: THE LOG OF SUBSURFACE CONDITIONS SHOWN HEREON APPLIES ONLY AT THE SPECIFIC BORING OR TRENCH LOCATION AND AT THE DATE INDICATED. IT IS NOT WARRANTED TO BE REPRESENTATIVE OF SUBSURFACE CONDITIONS AT OTHER LOCATIONS AND TIMES.

DEPTH IN FEET	SAMPLE NO.	LITHOLOGY	GROUNDWATER	SOIL CLASS (USCS)	BORING B 13		PENETRATION RESISTANCE (BLOWS/FT.)	DRY DENSITY (P.C.F.)	MOISTURE CONTENT (%)
					ELEV. (MSL.) <u>560'</u>	DATE COMPLETED <u>09-04-2012</u>			
					EQUIPMENT <u>EZ BORE</u>		BY: <u>M. ERTWINE</u>		
MATERIAL DESCRIPTION									
0				SC	TOPSOIL Loose, dry, brown, Clayey, fine to medium SAND				
2				SM	OTAY FORMATION (To) Medium dense to dense, light gray, Silty, fine- to medium-grained SANDSTONE				
4					-Becomes dense; slightly cemented				
6									
8									
10	B13-1			SM	Very dense, damp, light gray, Silty, fine- to medium-grained SANDSTONE; moderately cemented	8	114.1	13.5	
12									
14									
16				CL	Hard, damp, olive brown, Sandy CLAYSTONE				
18				SM	Very dense, damp, gray, Silty, fine-grained SANDSTONE; medium cemented				
20	B13-2			SM	Very dense, damp, light gray, Silty, fine-grained SANDSTONE	5	90.9	28.2	
22				CH	Hard, moist, brown, Silty, bentonitic CLAYSTONE approximately 1 foot thick; poorly developed				
24				SM	Very dense, damp, grayish brown, Silty, fine- to medium-grained SANDSTONE;				
26									
28									

Figure A-13,
Log of Boring B 13, Page 1 of 2

G1006-11-05.GPJ

SAMPLE SYMBOLS		... SAMPLING UNSUCCESSFUL		... STANDARD PENETRATION TEST		... DRIVE SAMPLE (UNDISTURBED)
		... DISTURBED OR BAG SAMPLE		... CHUNK SAMPLE		... WATER TABLE OR ... SEEPAGE

NOTE: THE LOG OF SUBSURFACE CONDITIONS SHOWN HEREON APPLIES ONLY AT THE SPECIFIC BORING OR TRENCH LOCATION AND AT THE DATE INDICATED. IT IS NOT WARRANTED TO BE REPRESENTATIVE OF SUBSURFACE CONDITIONS AT OTHER LOCATIONS AND TIMES.











DEPTH IN FEET	SAMPLE NO.	LITHOLOGY	GROUNDWATER	SOIL CLASS (USCS)	BORING B 13		PENETRATION RESISTANCE (BLOWS/FT.)	DRY DENSITY (P.C.F.)	MOISTURE CONTENT (%)
					ELEV. (MSL.) <u>560'</u>	DATE COMPLETED <u>09-04-2012</u>			
					EQUIPMENT <u>EZ BORE</u> BY: <u>M. ERTWINE</u>				
MATERIAL DESCRIPTION									
30	B13-3			CH	-Becomes light gray to whitish with trace rip-up clast of whitish bentonite CLAYSTONE within SANDSTONE matrix Hard, damp, pinkish to grayish brown, bentonitic CLAYSTONE; N25°, 5°SE; approx. 12-inch thick; fractural and well developed		6	66.1	49.5
32				SM					
34	B13-4			SM	Very dense, damp, light brown, Silty, fine-grained SANDSTONE		10/10"	114.4	14.6
42									
44					-Auger attached				
46					-Very dense, difficult drilling				
50	B13-5				-Massive		10/10"	119.2	11.6
					BORING TERMINATED AT 51 FEET No groundwater encountered				

Figure A-13,
Log of Boring B 13, Page 2 of 2

G1006-11-05.GPJ

SAMPLE SYMBOLS	 ... SAMPLING UNSUCCESSFUL	 ... STANDARD PENETRATION TEST	 ... DRIVE SAMPLE (UNDISTURBED)
	 ... DISTURBED OR BAG SAMPLE	 ... CHUNK SAMPLE	 ... WATER TABLE OR  ... SEEPAGE

NOTE: THE LOG OF SUBSURFACE CONDITIONS SHOWN HEREON APPLIES ONLY AT THE SPECIFIC BORING OR TRENCH LOCATION AND AT THE DATE INDICATED. IT IS NOT WARRANTED TO BE REPRESENTATIVE OF SUBSURFACE CONDITIONS AT OTHER LOCATIONS AND TIMES.

DEPTH IN FEET	SAMPLE NO.	LITHOLOGY	GROUNDWATER	SOIL CLASS (USCS)	BORING B 14		PENETRATION RESISTANCE (BLOWS/FT.)	DRY DENSITY (P.C.F.)	MOISTURE CONTENT (%)	
					ELEV. (MSL.) <u>436'</u>	DATE COMPLETED <u>09-04-2012</u>				
					EQUIPMENT <u>EZ BORE</u>		BY: <u>M. ERTWINE</u>			
MATERIAL DESCRIPTION										
0				SC	TOPSOIL Loose, moist, brown, Clayey, fine to medium SAND					
2				SM	OTAY FORMATION (To) Medium dense, moist, light grayish brown, Silty, fine-grained SANDSTONE; trace clay					
4										
6										
8										
10	B14-1			SM	Dense, damp, light gray, Silty, fine-grained SANDSTONE; slightly cemented; trace clay and manganese oxide staining	4	111.2	16.7		
12										
14										
16					-Thinly bedded					
18					-Very difficult excavation					
20	B14-2			SM	Very dense, moist, grayish brown, Silty, fine-grained SANDSTONE; moderately cemented; trace gravel	8/10"	115.6	14.7		
22										
24										
26				SM	Very dense, damp, grayish brown, medium- to coarse-grained SANDSTONE					
28										
					BORING TERMINATED AT 28 FEET No groundwater encountered					

Figure A-14,
Log of Boring B 14, Page 1 of 1

G1006-11-05.GPJ







SAMPLE SYMBOLS		... SAMPLING UNSUCCESSFUL		... STANDARD PENETRATION TEST		... DRIVE SAMPLE (UNDISTURBED)
		... DISTURBED OR BAG SAMPLE		... CHUNK SAMPLE		... WATER TABLE OR ... SEEPAGE

NOTE: THE LOG OF SUBSURFACE CONDITIONS SHOWN HEREON APPLIES ONLY AT THE SPECIFIC BORING OR TRENCH LOCATION AND AT THE DATE INDICATED. IT IS NOT WARRANTED TO BE REPRESENTATIVE OF SUBSURFACE CONDITIONS AT OTHER LOCATIONS AND TIMES.

DEPTH IN FEET	SAMPLE NO.	LITHOLOGY	GROUNDWATER	SOIL CLASS (USCS)	BORING B 15		PENETRATION RESISTANCE (BLOWS/FT.)	DRY DENSITY (P.C.F.)	MOISTURE CONTENT (%)
					ELEV. (MSL.) <u>444'</u>	DATE COMPLETED <u>09-05-2012</u>			
					EQUIPMENT <u>EZ BORE</u>		BY: <u>M. ERTWINE</u>		
MATERIAL DESCRIPTION									
0				SM	TOPSOIL Loose, damp, brown, Silty, fine to medium SAND				
2				SM	OTAY FORMATION (To) Medium dense, damp, light gray, Silty, fine- to medium-grained SANDSTONE; trace carbonates				
4									
6									
8					-Becomes dense; moderately cemented				
10									
12									
14				CL	Hard, moist, olive brown, Sandy CLAYSTONE				
16									
18				CL	Hard, moist, olive brown, Silty CLAYSTONE; grades to bentonite claystone at 21 feet				
20									
22				CH	Medium stiff, moist, whitish gray, bentonitic CLAYSTONE				
24				SM	Very dense, damp, reddish brown, Silty, fine-grained SANDSTONE				
26				SM	Very dense, damp, gray, Silty, fine- to medium-grained SANDSTONE				
28					BORING TERMINATED AT 28 FEET No groundwater encountered				

Figure A-15,
Log of Boring B 15, Page 1 of 1

G1006-11-05.GPJ

SAMPLE SYMBOLS	 ... SAMPLING UNSUCCESSFUL	 ... STANDARD PENETRATION TEST	 ... DRIVE SAMPLE (UNDISTURBED)
	 ... DISTURBED OR BAG SAMPLE	 ... CHUNK SAMPLE	 ... WATER TABLE OR  ... SEEPAGE

NOTE: THE LOG OF SUBSURFACE CONDITIONS SHOWN HEREON APPLIES ONLY AT THE SPECIFIC BORING OR TRENCH LOCATION AND AT THE DATE INDICATED. IT IS NOT WARRANTED TO BE REPRESENTATIVE OF SUBSURFACE CONDITIONS AT OTHER LOCATIONS AND TIMES.

DEPTH IN FEET	SAMPLE NO.	LITHOLOGY	GROUNDWATER	SOIL CLASS (USCS)	BORING B 16		PENETRATION RESISTANCE (BLOWS/FT.)	DRY DENSITY (P.C.F.)	MOISTURE CONTENT (%)
					ELEV. (MSL.) <u>586'</u>	DATE COMPLETED <u>09-05-2012</u>			
					EQUIPMENT <u>EZ BORE</u> BY: <u>M. ERTWINE</u>				
MATERIAL DESCRIPTION									
0				SC	TOPSOIL Loose, moist, brown, Clayey, fine to medium SAND				
2				SM	OTAY FORMATION (To) Medium dense, moist, gray, Silty, fine- to medium-grained SANDSTONE; blocky texture; trace carbonate				
4					-Becomes dense				
6									
8									
10	B16-1			SM	Dense, damp, light gray, Silty, fine grained SANDSTONE; slightly cemented	7	119.0	10.3	
12									
14				CH	Very hard, olive brown, bentonitic CLAYSTONE approx. 1.5 feet thick				
16				SM	Very dense, light grayish brown, Silty, fine grained SANDSTONE; moderately cemented				
18									
20	B16-2					5	111.3	14.0	
22					-Becomes well cemented				
24									
26				ML	Very hard, damp, gray, Sandy SILTSTONE				
28	B16-3					10	116.3	15.1	

Figure A-16,
Log of Boring B 16, Page 1 of 2

G1006-11-05.GPJ

SAMPLE SYMBOLS		... SAMPLING UNSUCCESSFUL		... STANDARD PENETRATION TEST		... DRIVE SAMPLE (UNDISTURBED)
		... DISTURBED OR BAG SAMPLE		... CHUNK SAMPLE		... WATER TABLE OR ... SEEPAGE

NOTE: THE LOG OF SUBSURFACE CONDITIONS SHOWN HEREON APPLIES ONLY AT THE SPECIFIC BORING OR TRENCH LOCATION AND AT THE DATE INDICATED. IT IS NOT WARRANTED TO BE REPRESENTATIVE OF SUBSURFACE CONDITIONS AT OTHER LOCATIONS AND TIMES.

DEPTH IN FEET	SAMPLE NO.	LITHOLOGY	GROUNDWATER	SOIL CLASS (USCS)	BORING B 17		PENETRATION RESISTANCE (BLOWS/FT.)	DRY DENSITY (P.C.F.)	MOISTURE CONTENT (%)
					ELEV. (MSL.) <u>604'</u>	DATE COMPLETED <u>09-05-2012</u>			
					EQUIPMENT <u>EZ BORE</u>		BY: <u>M. ERTWINE</u>		
MATERIAL DESCRIPTION									
0				SC	TOPSOIL Loose, moist, brown, Clayey, fine to medium SAND				
2				SM	OTAY FORMATION (To) Medium dense, moist, light gray, Silty, fine- to medium-grained SANDSTONE; blocky texture				
4									
6									
8									
10				SM	Very dense, gray, Silty, fine-grained SANDSTONE				
12	B17-1			CL	Hard, damp, light olive brown, Sandy CLAYSTONE	5	99.8	23.5	
14				SM	Very dense, gray, Silty, fine- to medium-grained SANDSTONE; slightly cemented				
16									
18									
20	B17-2			SM	Very dense, damp, light gray, Silty, fine- to medium-grained SANDSTONE; moderately cemented	10	115.2	13.3	
22									
24									
26					-Homogeneous				
28				SM	Very dense, damp, grayish brown, Silty, fine to medium SANDSTONE; well cemented				

Figure A-17,
Log of Boring B 17, Page 1 of 2

G1006-11-05.GPJ

SAMPLE SYMBOLS		... SAMPLING UNSUCCESSFUL		... STANDARD PENETRATION TEST		... DRIVE SAMPLE (UNDISTURBED)
		... DISTURBED OR BAG SAMPLE		... CHUNK SAMPLE		... WATER TABLE OR ... SEEPAGE

NOTE: THE LOG OF SUBSURFACE CONDITIONS SHOWN HEREON APPLIES ONLY AT THE SPECIFIC BORING OR TRENCH LOCATION AND AT THE DATE INDICATED. IT IS NOT WARRANTED TO BE REPRESENTATIVE OF SUBSURFACE CONDITIONS AT OTHER LOCATIONS AND TIMES.













DEPTH IN FEET	SAMPLE NO.	LITHOLOGY	GROUNDWATER	SOIL CLASS (USCS)	BORING B 17		PENETRATION RESISTANCE (BLOWS/FT.)	DRY DENSITY (P.C.F.)	MOISTURE CONTENT (%)
					ELEV. (MSL.) <u>604'</u>	DATE COMPLETED <u>09-05-2012</u>			
					EQUIPMENT <u>EZ BORE</u> BY: <u>M. ERTWINE</u>				
					MATERIAL DESCRIPTION				
30	B17-3				Very hard, damp, olive gray, bentonitic CLAYSTONE; poorly developed				
32				CH					
34				SM	Very dense, damp, grayish brown, Silty, fine to medium SANDSTONE; well cemented				
36									
38					BORING TERMINATED AT 40 FEET No groundwater encountered				
40									

Figure A-17,
Log of Boring B 17, Page 2 of 2

G1006-11-05.GPJ

SAMPLE SYMBOLS		... SAMPLING UNSUCCESSFUL		... STANDARD PENETRATION TEST		... DRIVE SAMPLE (UNDISTURBED)
		... DISTURBED OR BAG SAMPLE		... CHUNK SAMPLE		... WATER TABLE OR  ... SEEPAGE

NOTE: THE LOG OF SUBSURFACE CONDITIONS SHOWN HEREON APPLIES ONLY AT THE SPECIFIC BORING OR TRENCH LOCATION AND AT THE DATE INDICATED. IT IS NOT WARRANTED TO BE REPRESENTATIVE OF SUBSURFACE CONDITIONS AT OTHER LOCATIONS AND TIMES.

DEPTH IN FEET	SAMPLE NO.	LITHOLOGY	GROUNDWATER	SOIL CLASS (USCS)	BORING B 18		PENETRATION RESISTANCE (BLOWS/FT.)	DRY DENSITY (P.C.F.)	MOISTURE CONTENT (%)	
					ELEV. (MSL.) <u>446'</u>	DATE COMPLETED <u>09-05-2012</u>				
					EQUIPMENT <u>EZ BORE</u> BY: <u>M. ERTWINE</u>					
MATERIAL DESCRIPTION										
0				SC	TOPSOIL Loose, moist, brown, Clayey, fine to medium SAND					
2										
4				SM	OTAY FORMATION (To) Dense, moist, light gray, Silty, fine-grained SANDSTONE					
6										
8				CH	Medium stiff, damp, whitish gray, bentonite CLAYSTONE; highly weathered; trace rootlets and carbonates; well developed					
				SM	Very dense, damp, light reddish brown, Silty, fine grained SANDSTONE					
10	B18-1			SM	Very dense, damp, light grayish brown, Silty, fine- to medium-grained SANDSTONE	6/10"	110.6	8.9		
12										
14										
16										
18										
20	B18-2					50/10"	109.6	18.6		
					BORING TERMINATED AT 21 FEET No groundwater encountered					

Figure A-18,
Log of Boring B 18, Page 1 of 1

G1006-11-05.GPJ







SAMPLE SYMBOLS	... SAMPLING UNSUCCESSFUL	... STANDARD PENETRATION TEST	... DRIVE SAMPLE (UNDISTURBED)
	... DISTURBED OR BAG SAMPLE	... CHUNK SAMPLE	... WATER TABLE OR ... SEEPAGE

NOTE: THE LOG OF SUBSURFACE CONDITIONS SHOWN HEREON APPLIES ONLY AT THE SPECIFIC BORING OR TRENCH LOCATION AND AT THE DATE INDICATED. IT IS NOT WARRANTED TO BE REPRESENTATIVE OF SUBSURFACE CONDITIONS AT OTHER LOCATIONS AND TIMES.

DEPTH IN FEET	SAMPLE NO.	LITHOLOGY	GROUNDWATER	SOIL CLASS (USCS)	BORING B 19		PENETRATION RESISTANCE (BLOWS/FT.)	DRY DENSITY (P.C.F.)	MOISTURE CONTENT (%)
					ELEV. (MSL.) <u>404'</u>	DATE COMPLETED <u>09-05-2012</u>			
					EQUIPMENT <u>EZ BORE</u>		BY: <u>M. ERTWINE</u>		
MATERIAL DESCRIPTION									
0				SM	TOPSOIL Loose, damp, Silty, fine to medium SAND; krotovina from 2.5 to 3 feet				
2									
4				SM	OTAY FORMATION (To) Dense, moist, light gray, Silty, fine- to medium-grained SANDSTONE				
6									
8					-Becomes reddish brown with locally cemented zones				
10	B19-1			SM	Dense, damp, light grayish brown, Silty, fine- to medium-grained SANDSTONE; slightly cemented		8	114.0	16.3
12									
14					-Alternating layers of siltstone/sandstone				
16					-Cemented zone; some gravels				
18				SM	Very dense, damp, grayish brown, Silty, fine to grained SANDSTONE				
20	B19-2						8	109.6	14.5
					BORING TERMINATED AT 21 FEET No groundwater encountered				

Figure A-19,
Log of Boring B 19, Page 1 of 1

G1006-11-05.GPJ

SAMPLE SYMBOLS	 ... SAMPLING UNSUCCESSFUL	 ... STANDARD PENETRATION TEST	 ... DRIVE SAMPLE (UNDISTURBED)
	 ... DISTURBED OR BAG SAMPLE	 ... CHUNK SAMPLE	 ... WATER TABLE OR  ... SEEPAGE

NOTE: THE LOG OF SUBSURFACE CONDITIONS SHOWN HEREON APPLIES ONLY AT THE SPECIFIC BORING OR TRENCH LOCATION AND AT THE DATE INDICATED. IT IS NOT WARRANTED TO BE REPRESENTATIVE OF SUBSURFACE CONDITIONS AT OTHER LOCATIONS AND TIMES.

DEPTH IN FEET	SAMPLE NO.	LITHOLOGY	GROUNDWATER	SOIL CLASS (USCS)	TRENCH T 1			PENETRATION RESISTANCE (BLOWS/FT.)	DRY DENSITY (P.C.F.)	MOISTURE CONTENT (%)
					ELEV. (MSL.) <u>370'</u>	DATE COMPLETED <u>02-21-2012</u>	EQUIPMENT <u>BACKHOE JD 455</u> BY: <u>E. MILLER</u>			
MATERIAL DESCRIPTION										
0	T1-1			SC	ALLUVIUM (Qal) Loose to medium dense, damp, dark brown, Clayey, fine-to coarse SAND; some cobbles					
2										
4	T1-2			SM	Medium dense, damp, light brown to grayish brown, Silty, fine to coarse SAND; up to 1/2" gravel					
6										
				SM	OTAY FORMATION (Tog) Very dense, damp, light grayish brown, Silty, fine-to coarse-grained SANDSTONE; ("GRITSTONE") up to 1/2" gravel					
					TRENCH TERMINATED AT 7 FEET No groundwater encountered					

Figure A-20,
Log of Trench T 1, Page 1 of 1

G1006-11-05.GPJ

SAMPLE SYMBOLS		... SAMPLING UNSUCCESSFUL		... STANDARD PENETRATION TEST		... DRIVE SAMPLE (UNDISTURBED)
		... DISTURBED OR BAG SAMPLE		... CHUNK SAMPLE		... WATER TABLE OR ... SEEPAGE

NOTE: THE LOG OF SUBSURFACE CONDITIONS SHOWN HEREON APPLIES ONLY AT THE SPECIFIC BORING OR TRENCH LOCATION AND AT THE DATE INDICATED. IT IS NOT WARRANTED TO BE REPRESENTATIVE OF SUBSURFACE CONDITIONS AT OTHER LOCATIONS AND TIMES.

DEPTH IN FEET	SAMPLE NO.	LITHOLOGY	GROUNDWATER	SOIL CLASS (USCS)	TRENCH T 2		PENETRATION RESISTANCE (BLOWS/FT.)	DRY DENSITY (P.C.F.)	MOISTURE CONTENT (%)
					ELEV. (MSL.) <u>370'</u>	DATE COMPLETED <u>02-21-2012</u>			
					EQUIPMENT <u>BACKHOE JD 455</u>		BY: <u>E. MILLER</u>		
MATERIAL DESCRIPTION									
0				CL	ALLUVIUM (Qal) Loose, moist, dark brown, fine Sandy CLAY; rootlets				
2				SM	Loose to medium dense, dry, dark grayish brown, Silty, fine SAND; trace clay lense				
4					-Trace carbonates				
6				SC	Medium dense, moist, dark brown with lighter nodules of Silty SAND, Clayey, fine to medium SAND or Sandy CLAY				
8				SC	OTAY FORMATION (To) Very dense, moist, light brown to white, Clayey, fine-to coarse grained SANDSTONE; trace gravel up to 3", oxidized				
					TRENCH TERMINATED AT 8 FEET No groundwater encountered				

Figure A-21,
Log of Trench T 2, Page 1 of 1

G1006-11-05.GPJ

SAMPLE SYMBOLS	... SAMPLING UNSUCCESSFUL	... STANDARD PENETRATION TEST	... DRIVE SAMPLE (UNDISTURBED)
	... DISTURBED OR BAG SAMPLE	... CHUNK SAMPLE	... WATER TABLE OR ... SEEPAGE

NOTE: THE LOG OF SUBSURFACE CONDITIONS SHOWN HEREON APPLIES ONLY AT THE SPECIFIC BORING OR TRENCH LOCATION AND AT THE DATE INDICATED. IT IS NOT WARRANTED TO BE REPRESENTATIVE OF SUBSURFACE CONDITIONS AT OTHER LOCATIONS AND TIMES.









DEPTH IN FEET	SAMPLE NO.	LITHOLOGY	GROUNDWATER	SOIL CLASS (USCS)	TRENCH T 3		PENETRATION RESISTANCE (BLOWS/FT.)	DRY DENSITY (P.C.F.)	MOISTURE CONTENT (%)
					ELEV. (MSL.) <u>380'</u>	DATE COMPLETED <u>02-21-2012</u>			
					EQUIPMENT <u>BACKHOE JD 455</u>		BY: <u>E. MILLER</u>		
MATERIAL DESCRIPTION									
0				CL	ALLUVIUM (Qal) Loose, moist, dark brown, fine-to medium Sandy CLAY				
2									
4				SC	OTAY FORMATION (To) Dense to very dense, damp, light brown, Clayey, fine to coarse-grained SANDSTONE				
6									
					TRENCH TERMINATED AT 7 FEET No groundwater encountered				

Figure A-22,
Log of Trench T 3, Page 1 of 1

G1006-11-05.GPJ

SAMPLE SYMBOLS		... SAMPLING UNSUCCESSFUL		... STANDARD PENETRATION TEST		... DRIVE SAMPLE (UNDISTURBED)
		... DISTURBED OR BAG SAMPLE		... CHUNK SAMPLE		... WATER TABLE OR  ... SEEPAGE

NOTE: THE LOG OF SUBSURFACE CONDITIONS SHOWN HEREON APPLIES ONLY AT THE SPECIFIC BORING OR TRENCH LOCATION AND AT THE DATE INDICATED. IT IS NOT WARRANTED TO BE REPRESENTATIVE OF SUBSURFACE CONDITIONS AT OTHER LOCATIONS AND TIMES.







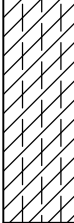

DEPTH IN FEET	SAMPLE NO.	LITHOLOGY	GROUNDWATER	SOIL CLASS (USCS)	TRENCH T 4		PENETRATION RESISTANCE (BLOWS/FT.)	DRY DENSITY (P.C.F.)	MOISTURE CONTENT (%)
					ELEV. (MSL.) <u>410'</u>	DATE COMPLETED <u>02-21-2012</u>			
					EQUIPMENT <u>BACKHOE JD 455</u> BY: <u>E. MILLER</u>				
MATERIAL DESCRIPTION									
0				CL	ALLUVIUM (Qal) Loose, damp to moist, dark brown, Silty CLAY				
2						-Few carbonates			
4									
6				SM	OTAY FORMATION (To) Dense to very dense, damp, light grayish brown, Silty, fine-to coarse-grained SANDSTONE; few gravel				
					TRENCH TERMINATED AT 7 FEET No groundwater encountered				

Figure A-23,
Log of Trench T 4, Page 1 of 1

G1006-11-05.GPJ

SAMPLE SYMBOLS	 ... SAMPLING UNSUCCESSFUL	 ... STANDARD PENETRATION TEST	 ... DRIVE SAMPLE (UNDISTURBED)
	 ... DISTURBED OR BAG SAMPLE	 ... CHUNK SAMPLE	 ... WATER TABLE OR  ... SEEPAGE

NOTE: THE LOG OF SUBSURFACE CONDITIONS SHOWN HEREON APPLIES ONLY AT THE SPECIFIC BORING OR TRENCH LOCATION AND AT THE DATE INDICATED. IT IS NOT WARRANTED TO BE REPRESENTATIVE OF SUBSURFACE CONDITIONS AT OTHER LOCATIONS AND TIMES.

DEPTH IN FEET	SAMPLE NO.	LITHOLOGY	GROUNDWATER	SOIL CLASS (USCS)	TRENCH T 5		PENETRATION RESISTANCE (BLOWS/FT.)	DRY DENSITY (P.C.F.)	MOISTURE CONTENT (%)
					ELEV. (MSL.) <u>444'</u>	DATE COMPLETED <u>02-21-2012</u>			
					EQUIPMENT <u>BACKHOE JD 455</u> BY: <u>E. MILLER</u>				
MATERIAL DESCRIPTION									
0				SM	ALLUVIUM (Qal) Loose to medium dense, dry to damp, grayish brown, Silty, fine to medium SAND; trace clay and rootlets				
2									
4									
6				SM	OTAY FORMATION (To) Dense to very dense, dry, light brown, fine-grained SANDSTONE; weakly cemented, massive				
					TRENCH TERMINATED AT 7 FEET No groundwater encountered				

Figure A-24,
Log of Trench T 5, Page 1 of 1

G1006-11-05.GPJ







SAMPLE SYMBOLS		
	... SAMPLING UNSUCCESSFUL	
	... DISTURBED OR BAG SAMPLE	
	... CHUNK SAMPLE	
	... WATER TABLE OR	
	... SEE PAGE	

NOTE: THE LOG OF SUBSURFACE CONDITIONS SHOWN HEREON APPLIES ONLY AT THE SPECIFIC BORING OR TRENCH LOCATION AND AT THE DATE INDICATED. IT IS NOT WARRANTED TO BE REPRESENTATIVE OF SUBSURFACE CONDITIONS AT OTHER LOCATIONS AND TIMES.

DEPTH IN FEET	SAMPLE NO.	LITHOLOGY	GROUNDWATER	SOIL CLASS (USCS)	TRENCH T 6		PENETRATION RESISTANCE (BLOWS/FT.)	DRY DENSITY (P.C.F.)	MOISTURE CONTENT (%)
					ELEV. (MSL.) <u>488'</u>	DATE COMPLETED <u>02-21-2012</u>			
					EQUIPMENT <u>BACKHOE JD 455</u>		BY: <u>E. MILLER</u>		
MATERIAL DESCRIPTION									
0				SC-CL	ALLUVIUM (Qal) Loose to medium dense, damp, dark brown, Clayey, fine to medium SAND or fine to medium Sandy CLAY				
2									
4				SM	OTAY FORMATION (To) Very dense, dry, light brown to white, Silty, fine-grained SANDSTONE, moderately cemented				
6	T6-1				TRENCH TERMINATED AT 6 FEET No groundwater encountered				

Figure A-25,
Log of Trench T 6, Page 1 of 1

G1006-11-05.GPJ

SAMPLE SYMBOLS	 ... SAMPLING UNSUCCESSFUL	 ... STANDARD PENETRATION TEST	 ... DRIVE SAMPLE (UNDISTURBED)
	 ... DISTURBED OR BAG SAMPLE	 ... CHUNK SAMPLE	 ... WATER TABLE OR  ... SEEPAGE

NOTE: THE LOG OF SUBSURFACE CONDITIONS SHOWN HEREON APPLIES ONLY AT THE SPECIFIC BORING OR TRENCH LOCATION AND AT THE DATE INDICATED. IT IS NOT WARRANTED TO BE REPRESENTATIVE OF SUBSURFACE CONDITIONS AT OTHER LOCATIONS AND TIMES.









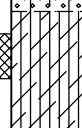

DEPTH IN FEET	SAMPLE NO.	LITHOLOGY	GROUNDWATER	SOIL CLASS (USCS)	TRENCH T 7		PENETRATION RESISTANCE (BLOWS/FT.)	DRY DENSITY (P.C.F.)	MOISTURE CONTENT (%)
					ELEV. (MSL.) <u>560'</u>	DATE COMPLETED <u>02-21-2012</u>			
					EQUIPMENT <u>BACKHOE JD 455</u>		BY: <u>E. MILLER</u>		
MATERIAL DESCRIPTION									
0				SC	TOPSOIL Loose, moist, dark brown, Clayey, fine SAND; rootlets				
2				SM	OTAY FORMATION (To) Dense, dry, light gray, Silty, fine-grained SANDSTONE; moderately cemented; blocky structure				
4				ML	Stiff, dry, light brown, Clayey SILTSTONE				
6	T7-1								
8					TRENCH TERMINATED AT 8 FEET No groundwater encountered				

Figure A-26,
Log of Trench T 7, Page 1 of 1

G1006-11-05.GPJ

SAMPLE SYMBOLS		... SAMPLING UNSUCCESSFUL		... STANDARD PENETRATION TEST		... DRIVE SAMPLE (UNDISTURBED)
		... DISTURBED OR BAG SAMPLE		... CHUNK SAMPLE		... WATER TABLE OR  ... SEEPAGE

NOTE: THE LOG OF SUBSURFACE CONDITIONS SHOWN HEREON APPLIES ONLY AT THE SPECIFIC BORING OR TRENCH LOCATION AND AT THE DATE INDICATED. IT IS NOT WARRANTED TO BE REPRESENTATIVE OF SUBSURFACE CONDITIONS AT OTHER LOCATIONS AND TIMES.









DEPTH IN FEET	SAMPLE NO.	LITHOLOGY	GROUNDWATER	SOIL CLASS (USCS)	TRENCH T 8		PENETRATION RESISTANCE (BLOWS/FT.)	DRY DENSITY (P.C.F.)	MOISTURE CONTENT (%)
					ELEV. (MSL.) <u>570'</u>	DATE COMPLETED <u>02-21-2012</u>			
					EQUIPMENT <u>BACKHOE JD 455</u>		BY: <u>E. MILLER</u>		
MATERIAL DESCRIPTION									
0				SM	TOPSOIL Loose, damp to moist, dark brown to dark grayish brown, Silty, fine SAND; some clay; trace rootlets				
2				SM	OTAY FORMATION (To) Dense to very dense, damp, light brownish gray, Silty, fine-grained SANDSTONE; very thinly bedded to moderately bedded -Massive and homogeneous				
4									
6									
8									
					TRENCH TERMINATED AT 9 FEET No groundwater encountered				

Figure A-27,
Log of Trench T 8, Page 1 of 1

G1006-11-05.GPJ

SAMPLE SYMBOLS		... SAMPLING UNSUCCESSFUL		... STANDARD PENETRATION TEST		... DRIVE SAMPLE (UNDISTURBED)
		... DISTURBED OR BAG SAMPLE		... CHUNK SAMPLE		... WATER TABLE OR  ... SEEPAGE

NOTE: THE LOG OF SUBSURFACE CONDITIONS SHOWN HEREON APPLIES ONLY AT THE SPECIFIC BORING OR TRENCH LOCATION AND AT THE DATE INDICATED. IT IS NOT WARRANTED TO BE REPRESENTATIVE OF SUBSURFACE CONDITIONS AT OTHER LOCATIONS AND TIMES.









DEPTH IN FEET	SAMPLE NO.	LITHOLOGY	GROUNDWATER	SOIL CLASS (USCS)	<p style="text-align: center;">TRENCH T 9</p> <p>ELEV. (MSL.) <u>444'</u> DATE COMPLETED <u>02-22-2012</u></p> <p>EQUIPMENT <u>BACKHOE JD 455</u> BY: <u>E. MILLER</u></p>	PENETRATION RESISTANCE (BLOWS/FT.)	DRY DENSITY (P.C.F.)	MOISTURE CONTENT (%)
MATERIAL DESCRIPTION								
0				SC	<p>TOPSOIL Loose to medium dense, damp, dark brown, Clayey, fine SAND; rootlets; trace carbonates and krotovinas</p>			
2								
4				SM	<p>OTAY FORMATION (To) Very dense, dry, light grayish brown, Silty, fine-grained SANDSTONE</p>			
6								
TRENCH TERMINATED AT 6 FEET No groundwater encountered								

Figure A-28,
Log of Trench T 9, Page 1 of 1

G1006-11-05.GPJ

SAMPLE SYMBOLS	 ... SAMPLING UNSUCCESSFUL	 ... STANDARD PENETRATION TEST	 ... DRIVE SAMPLE (UNDISTURBED)
	 ... DISTURBED OR BAG SAMPLE	 ... CHUNK SAMPLE	 ... WATER TABLE OR  ... SEEPAGE

NOTE: THE LOG OF SUBSURFACE CONDITIONS SHOWN HEREON APPLIES ONLY AT THE SPECIFIC BORING OR TRENCH LOCATION AND AT THE DATE INDICATED. IT IS NOT WARRANTED TO BE REPRESENTATIVE OF SUBSURFACE CONDITIONS AT OTHER LOCATIONS AND TIMES.









DEPTH IN FEET	SAMPLE NO.	LITHOLOGY	GROUNDWATER	SOIL CLASS (USCS)	TRENCH T 10		PENETRATION RESISTANCE (BLOWS/FT.)	DRY DENSITY (P.C.F.)	MOISTURE CONTENT (%)	
					ELEV. (MSL.) <u>520'</u>	DATE COMPLETED <u>02-22-2012</u>				
					EQUIPMENT <u>BACKHOE JD 455</u> BY: <u>E. MILLER</u>					
					MATERIAL DESCRIPTION					
0				SM	TOPSOIL Loose, damp, brown, Silty, fine SAND; rootlets, few carbonates					
2				SM	OTAY FORMATION (To) Dense to very dense, reddish brown, Silty, fine-grained SANDSTONE -Thinly to moderately bedded, light grayish brown; blocky texture, trace carbonates					
4	T10-1									
6					TRENCH TERMINATED AT 6.5 FEET No groundwater encountered					

Figure A-29,
Log of Trench T 10, Page 1 of 1

G1006-11-05.GPJ

SAMPLE SYMBOLS	 ... SAMPLING UNSUCCESSFUL	 ... STANDARD PENETRATION TEST	 ... DRIVE SAMPLE (UNDISTURBED)
	 ... DISTURBED OR BAG SAMPLE	 ... CHUNK SAMPLE	 ... WATER TABLE OR  ... SEEPAGE

NOTE: THE LOG OF SUBSURFACE CONDITIONS SHOWN HEREON APPLIES ONLY AT THE SPECIFIC BORING OR TRENCH LOCATION AND AT THE DATE INDICATED. IT IS NOT WARRANTED TO BE REPRESENTATIVE OF SUBSURFACE CONDITIONS AT OTHER LOCATIONS AND TIMES.

DEPTH IN FEET	SAMPLE NO.	LITHOLOGY	GROUNDWATER	SOIL CLASS (USCS)	TRENCH T 11		PENETRATION RESISTANCE (BLOWS/FT.)	DRY DENSITY (P.C.F.)	MOISTURE CONTENT (%)
					ELEV. (MSL.) <u>540'</u>	DATE COMPLETED <u>02-22-2012</u>			
					EQUIPMENT <u>BACKHOE JD 455</u>		BY: <u>E. MILLER</u>		
MATERIAL DESCRIPTION									
0				SM	TOPSOIL Loose, damp, brown, Silty, fine SAND; rootlets; trace carbonates				
2									
4				ML	OTAY FORMATION (To) Stiff to very stiff, dry, light grayish brown, fine Sandy SILTSTONE; very thinly bedded				
6									
					TRENCH TERMINATED AT 6 FEET No groundwater encountered				

Figure A-30,
Log of Trench T 11, Page 1 of 1

G1006-11-05.GPJ

SAMPLE SYMBOLS	... SAMPLING UNSUCCESSFUL	... STANDARD PENETRATION TEST	... DRIVE SAMPLE (UNDISTURBED)
	... DISTURBED OR BAG SAMPLE	... CHUNK SAMPLE	... WATER TABLE OR ... SEEPAGE

NOTE: THE LOG OF SUBSURFACE CONDITIONS SHOWN HEREON APPLIES ONLY AT THE SPECIFIC BORING OR TRENCH LOCATION AND AT THE DATE INDICATED. IT IS NOT WARRANTED TO BE REPRESENTATIVE OF SUBSURFACE CONDITIONS AT OTHER LOCATIONS AND TIMES.

DEPTH IN FEET	SAMPLE NO.	LITHOLOGY	GROUNDWATER	SOIL CLASS (USCS)	TRENCH T 12		PENETRATION RESISTANCE (BLOWS/FT.)	DRY DENSITY (P.C.F.)	MOISTURE CONTENT (%)
					ELEV. (MSL.) <u>510'</u>	DATE COMPLETED <u>02-22-2012</u>			
					EQUIPMENT <u>BACKHOE JD 455</u>		BY: <u>E. MILLER</u>		
MATERIAL DESCRIPTION									
0				SM	ALLUVIUM (Qal) Loose, dry to damp, brown to dark brown, Silty, fine SAND				
2						-Trace carbonates			
4				SM	OTAY FORMATION (To) Stiff, dry, light grayish brown, fine Sandy SILTSTONE to Silty fine SANDSTONE; slightly cemented				
6						-Decreased cohesive strength			
					TRENCH TERMINATED AT 7.5 FEET No groundwater encountered				

Figure A-31,
Log of Trench T 12, Page 1 of 1

G1006-11-05.GPJ

SAMPLE SYMBOLS		... SAMPLING UNSUCCESSFUL		... STANDARD PENETRATION TEST		... DRIVE SAMPLE (UNDISTURBED)
		... DISTURBED OR BAG SAMPLE		... CHUNK SAMPLE		... WATER TABLE OR ... SEEPAGE

NOTE: THE LOG OF SUBSURFACE CONDITIONS SHOWN HEREON APPLIES ONLY AT THE SPECIFIC BORING OR TRENCH LOCATION AND AT THE DATE INDICATED. IT IS NOT WARRANTED TO BE REPRESENTATIVE OF SUBSURFACE CONDITIONS AT OTHER LOCATIONS AND TIMES.









DEPTH IN FEET	SAMPLE NO.	LITHOLOGY	GROUNDWATER	SOIL CLASS (USCS)	TRENCH T 13		PENETRATION RESISTANCE (BLOWS/FT.)	DRY DENSITY (P.C.F.)	MOISTURE CONTENT (%)	
					ELEV. (MSL.) <u>446'</u>	DATE COMPLETED <u>02-22-2012</u>				
					EQUIPMENT <u>BACKHOE JD 455</u>		BY: <u>E. MILLER</u>			
MATERIAL DESCRIPTION										
0	T13-1			CL	ALLUVIUM (Qal) Soft, damp, dark brown, fine Sandy CLAY; trace rootlets					
2										
4								-Trace carbonates and krotovinas up to 8"		
				SM	Soft, damp, brown, Silty, fine SAND					
6				SM	OTAY FORMATION (To) Dense to very dense, damp, light grayish brown, Silty, fine-grained SANDSTONE; moderately cemented					
							TRENCH TERMINATED AT 7.5 FEET No groundwater encountered			

Figure A-32,
Log of Trench T 13, Page 1 of 1

G1006-11-05.GPJ

SAMPLE SYMBOLS	 ... SAMPLING UNSUCCESSFUL	 ... STANDARD PENETRATION TEST	 ... DRIVE SAMPLE (UNDISTURBED)
	 ... DISTURBED OR BAG SAMPLE	 ... CHUNK SAMPLE	 ... WATER TABLE OR  ... SEEPAGE

NOTE: THE LOG OF SUBSURFACE CONDITIONS SHOWN HEREON APPLIES ONLY AT THE SPECIFIC BORING OR TRENCH LOCATION AND AT THE DATE INDICATED. IT IS NOT WARRANTED TO BE REPRESENTATIVE OF SUBSURFACE CONDITIONS AT OTHER LOCATIONS AND TIMES.













DEPTH IN FEET	SAMPLE NO.	LITHOLOGY	GROUNDWATER	SOIL CLASS (USCS)	TRENCH T 14		PENETRATION RESISTANCE (BLOWS/FT.)	DRY DENSITY (P.C.F.)	MOISTURE CONTENT (%)
					ELEV. (MSL.) <u>450'</u>	DATE COMPLETED <u>02-22-2012</u>			
					EQUIPMENT <u>BACKHOE JD 455</u> BY: <u>E. MILLER</u>				
MATERIAL DESCRIPTION									
0				CL	ALLUVIUM (Qal) Soft to firm, damp to moist, dark brown, fine Sandy CLAY				
2				SM	Medium dense, damp, white to light brown with lenses of Silty, fine SAND				
4				SM	OTAY FORMATION (To) Dense, damp, light grayish brown, Silty, fine-grained SANDSTONE				
6				SM	-Becomes moderately cemented				
8					TRENCH TERMINATED AT 8.5 FEET No groundwater encountered				

Figure A-33,
Log of Trench T 14, Page 1 of 1

G1006-11-05.GPJ

SAMPLE SYMBOLS	 ... SAMPLING UNSUCCESSFUL	 ... STANDARD PENETRATION TEST	 ... DRIVE SAMPLE (UNDISTURBED)
	 ... DISTURBED OR BAG SAMPLE	 ... CHUNK SAMPLE	 ... WATER TABLE OR  ... SEEPAGE

NOTE: THE LOG OF SUBSURFACE CONDITIONS SHOWN HEREON APPLIES ONLY AT THE SPECIFIC BORING OR TRENCH LOCATION AND AT THE DATE INDICATED. IT IS NOT WARRANTED TO BE REPRESENTATIVE OF SUBSURFACE CONDITIONS AT OTHER LOCATIONS AND TIMES.









DEPTH IN FEET	SAMPLE NO.	LITHOLOGY	GROUNDWATER	SOIL CLASS (USCS)	TRENCH T 15		PENETRATION RESISTANCE (BLOWS/FT.)	DRY DENSITY (P.C.F.)	MOISTURE CONTENT (%)
					ELEV. (MSL.) <u>405'</u>	DATE COMPLETED <u>02-22-2012</u>			
					EQUIPMENT <u>BACKHOE JD 455</u> BY: <u>E. MILLER</u>				
MATERIAL DESCRIPTION									
0				CL	ALLUVIUM (Qal) Soft to firm, damp, dark brown, fine Sandy CLAY; rootlets				
2						-Trace carbonates, white to very light brown			
4				SC-SM	OTAY FORMATION (To) Dense to very dense, damp, light grayish brown, Silty, fine-to medium-grained SANDSTONE; moderately cemented				
6						TRENCH TERMINATED AT 6.5 FEET No groundwater encountered			

Figure A-34,
Log of Trench T 15, Page 1 of 1

G1006-11-05.GPJ

SAMPLE SYMBOLS		... SAMPLING UNSUCCESSFUL		... STANDARD PENETRATION TEST		... DRIVE SAMPLE (UNDISTURBED)
		... DISTURBED OR BAG SAMPLE		... CHUNK SAMPLE		... WATER TABLE OR  ... SEEPAGE

NOTE: THE LOG OF SUBSURFACE CONDITIONS SHOWN HEREON APPLIES ONLY AT THE SPECIFIC BORING OR TRENCH LOCATION AND AT THE DATE INDICATED. IT IS NOT WARRANTED TO BE REPRESENTATIVE OF SUBSURFACE CONDITIONS AT OTHER LOCATIONS AND TIMES.









DEPTH IN FEET	SAMPLE NO.	LITHOLOGY	GROUNDWATER	SOIL CLASS (USCS)	TRENCH T 16		PENETRATION RESISTANCE (BLOWS/FT.)	DRY DENSITY (P.C.F.)	MOISTURE CONTENT (%)
					ELEV. (MSL.) <u>415'</u>	DATE COMPLETED <u>02-22-2012</u>			
					EQUIPMENT <u>BACKHOE JD 455</u>		BY: <u>E. MILLER</u>		
MATERIAL DESCRIPTION									
0	T6-1			CL	ALLUVIUM (Qal) Soft to firm, damp, dark brown, fine Sandy CLAY; trace rootlets				
2									
4				SC-SM	OTAY FORMATION (To) Dense, light grayish brown and light brown, Clayey SANDSTONE; thinly bedded, light brown Silty, fine-grained SANDSTONE; with low cohesive strength				
6									
					TRENCH TERMINATED AT 7 FEET No groundwater encountered				

Figure A-35,
Log of Trench T 16, Page 1 of 1

G1006-11-05.GPJ

SAMPLE SYMBOLS		... SAMPLING UNSUCCESSFUL		... STANDARD PENETRATION TEST		... DRIVE SAMPLE (UNDISTURBED)
		... DISTURBED OR BAG SAMPLE		... CHUNK SAMPLE		... WATER TABLE OR  ... SEEPAGE

NOTE: THE LOG OF SUBSURFACE CONDITIONS SHOWN HEREON APPLIES ONLY AT THE SPECIFIC BORING OR TRENCH LOCATION AND AT THE DATE INDICATED. IT IS NOT WARRANTED TO BE REPRESENTATIVE OF SUBSURFACE CONDITIONS AT OTHER LOCATIONS AND TIMES.

DEPTH IN FEET	SAMPLE NO.	LITHOLOGY	GROUNDWATER	SOIL CLASS (USCS)	TRENCH T 17		PENETRATION RESISTANCE (BLOWS/FT.)	DRY DENSITY (P.C.F.)	MOISTURE CONTENT (%)
					ELEV. (MSL.) 392'	DATE COMPLETED 02-22-2012			
					EQUIPMENT BACKHOE JD 455		BY: E. MILLER		
MATERIAL DESCRIPTION									
0				CL	ALLUVIUM (Qal) Firm, damp, dark brown, fine Sandy CLAY				
2				SM	Medium dense, dry, dark brown, Silty SAND				
4				SC	-Becomes Clayey SAND; with trace carbonates				
6				SM	-Becomes reddish brown, Silty SAND; little gravel up to 3"				
8	T17-1			SM	OTAY FORMATION (To) Medium dense to dense, dry, light brown to very light brown, Silty, fine-to coarse-grained SANDSTONE; trace subangular gravel up to 3"; trace carbonates				
					TRENCH TERMINATED AT 9.5 FEET No groundwater encountered				

Figure A-36,
Log of Trench T 17, Page 1 of 1

G1006-11-05.GPJ

SAMPLE SYMBOLS		... SAMPLING UNSUCCESSFUL		... STANDARD PENETRATION TEST		... DRIVE SAMPLE (UNDISTURBED)
		... DISTURBED OR BAG SAMPLE		... CHUNK SAMPLE		... WATER TABLE OR ... SEEPAGE

NOTE: THE LOG OF SUBSURFACE CONDITIONS SHOWN HEREON APPLIES ONLY AT THE SPECIFIC BORING OR TRENCH LOCATION AND AT THE DATE INDICATED. IT IS NOT WARRANTED TO BE REPRESENTATIVE OF SUBSURFACE CONDITIONS AT OTHER LOCATIONS AND TIMES.









DEPTH IN FEET	SAMPLE NO.	LITHOLOGY	GROUNDWATER	SOIL CLASS (USCS)	TRENCH T 18		PENETRATION RESISTANCE (BLOWS/FT.)	DRY DENSITY (P.C.F.)	MOISTURE CONTENT (%)
					ELEV. (MSL.) <u>370'</u>	DATE COMPLETED <u>02-22-2012</u>			
					EQUIPMENT <u>BACKHOE JD 455</u>		BY: <u>E. MILLER</u>		
MATERIAL DESCRIPTION									
0				SC	ALLUVIUM (Qal) Medium dense, damp to moist, dark brown, Clayey, fine to medium SAND ; trace rootlets				
2						-Clayey, fine to coarse SAND; gravel up to 1/2"			
4									
6				SW	OTAY FORMATION (Tog) Very dense, damp, light yellowish brown, medium-to coarse-grained SANDSTONE; ("GRITSTONE"), trace subangular to subround gravel up to 1"				
					TRENCH TERMINATED AT 7 FEET No groundwater encountered				

Figure A-37,
Log of Trench T 18, Page 1 of 1

G1006-11-05.GPJ

SAMPLE SYMBOLS	 ... SAMPLING UNSUCCESSFUL	 ... STANDARD PENETRATION TEST	 ... DRIVE SAMPLE (UNDISTURBED)
	 ... DISTURBED OR BAG SAMPLE	 ... CHUNK SAMPLE	 ... WATER TABLE OR  ... SEEPAGE

NOTE: THE LOG OF SUBSURFACE CONDITIONS SHOWN HEREON APPLIES ONLY AT THE SPECIFIC BORING OR TRENCH LOCATION AND AT THE DATE INDICATED. IT IS NOT WARRANTED TO BE REPRESENTATIVE OF SUBSURFACE CONDITIONS AT OTHER LOCATIONS AND TIMES.









DEPTH IN FEET	SAMPLE NO.	LITHOLOGY	GROUNDWATER	SOIL CLASS (USCS)	TRENCH T 19		PENETRATION RESISTANCE (BLOWS/FT.)	DRY DENSITY (P.C.F.)	MOISTURE CONTENT (%)
					ELEV. (MSL.) <u>402'</u>	DATE COMPLETED <u>02-22-2012</u>			
					EQUIPMENT <u>BACKHOE JD 455</u> BY: <u>E. MILLER</u>				
MATERIAL DESCRIPTION									
0				SC	TOPSOIL Loose to medium dense, damp, dark brown, Clayey, fine to medium SAND; rootlets				
2				SM	-Trace carbonates				
4					OTAY FORMATION (To) Dense to very dense, damp, light yellowish brown, Silty, medium-to coarse-grained SANDSTONE; trace carbonates				
6					-Becomes very dense, grayish brown, fine-to coarse-grained SANDSTONE; moderately cemented				
					TRENCH TERMINATED AT 7 FEET No groundwater encountered				

Figure A-38,
Log of Trench T 19, Page 1 of 1

G1006-11-05.GPJ

SAMPLE SYMBOLS		... SAMPLING UNSUCCESSFUL		... STANDARD PENETRATION TEST		... DRIVE SAMPLE (UNDISTURBED)
		... DISTURBED OR BAG SAMPLE		... CHUNK SAMPLE		... WATER TABLE OR  ... SEEPAGE

NOTE: THE LOG OF SUBSURFACE CONDITIONS SHOWN HEREON APPLIES ONLY AT THE SPECIFIC BORING OR TRENCH LOCATION AND AT THE DATE INDICATED. IT IS NOT WARRANTED TO BE REPRESENTATIVE OF SUBSURFACE CONDITIONS AT OTHER LOCATIONS AND TIMES.









DEPTH IN FEET	SAMPLE NO.	LITHOLOGY	GROUNDWATER	SOIL CLASS (USCS)	TRENCH T 20		PENETRATION RESISTANCE (BLOWS/FT.)	DRY DENSITY (P.C.F.)	MOISTURE CONTENT (%)
					ELEV. (MSL.) <u>340'</u>	DATE COMPLETED <u>02-23-2012</u>			
					EQUIPMENT <u>BACKHOE JD 455</u> BY: <u>E. MILLER</u>				
MATERIAL DESCRIPTION									
0				SC	TOPSOIL Loose, damp to moist, dark brown, Clayey, fine to medium SAND; trace gravel up to 2"				
2				SW	OTAY FORMATION (Tog) Very dense, damp, light yellowish brown, medium-to coarse-grained SANDSTONE; ("GRITSTONE") subround to subangular gravel up to 3"				
4					TRENCH TERMINATED AT 5 FEET No groundwater encountered				

Figure A-39,
Log of Trench T 20, Page 1 of 1

G1006-11-05.GPJ

SAMPLE SYMBOLS	 ... SAMPLING UNSUCCESSFUL	 ... STANDARD PENETRATION TEST	 ... DRIVE SAMPLE (UNDISTURBED)
	 ... DISTURBED OR BAG SAMPLE	 ... CHUNK SAMPLE	 ... WATER TABLE OR  ... SEEPAGE

NOTE: THE LOG OF SUBSURFACE CONDITIONS SHOWN HEREON APPLIES ONLY AT THE SPECIFIC BORING OR TRENCH LOCATION AND AT THE DATE INDICATED. IT IS NOT WARRANTED TO BE REPRESENTATIVE OF SUBSURFACE CONDITIONS AT OTHER LOCATIONS AND TIMES.











DEPTH IN FEET	SAMPLE NO.	LITHOLOGY	GROUNDWATER	SOIL CLASS (USCS)	TRENCH T 21		PENETRATION RESISTANCE (BLOWS/FT.)	DRY DENSITY (P.C.F.)	MOISTURE CONTENT (%)
					ELEV. (MSL.) <u>358'</u>	DATE COMPLETED <u>02-23-2012</u>			
					EQUIPMENT <u>BACKHOE JD 455</u>		BY: <u>E. MILLER</u>		
MATERIAL DESCRIPTION									
0				CL	TOPSOIL Loose to medium dense, moist, dark brown, fine to medium Sandy CLAY; some rootlets				
2					-Trace carbonates				
4				SM	OTAY FORMATION (Tog) Medium dense to dense, damp, light yellowish brown, Silty, medium-to coarse-grained SANDSTONE				
6				SM	Dense, damp, light grayish brown, Silty, medium-to coarse-grained SANDSTONE; ("GRITSTONE") subround to subangular gravel up to 1/2"				
					TRENCH TERMINATED AT 6 FEET No groundwater encountered				

Figure A-40,
Log of Trench T 21, Page 1 of 1

G1006-11-05.GPJ

SAMPLE SYMBOLS	 ... SAMPLING UNSUCCESSFUL	 ... STANDARD PENETRATION TEST	 ... DRIVE SAMPLE (UNDISTURBED)
	 ... DISTURBED OR BAG SAMPLE	 ... CHUNK SAMPLE	 ... WATER TABLE OR  ... SEEPAGE

NOTE: THE LOG OF SUBSURFACE CONDITIONS SHOWN HEREON APPLIES ONLY AT THE SPECIFIC BORING OR TRENCH LOCATION AND AT THE DATE INDICATED. IT IS NOT WARRANTED TO BE REPRESENTATIVE OF SUBSURFACE CONDITIONS AT OTHER LOCATIONS AND TIMES.









DEPTH IN FEET	SAMPLE NO.	LITHOLOGY	GROUNDWATER	SOIL CLASS (USCS)	TRENCH T 22		PENETRATION RESISTANCE (BLOWS/FT.)	DRY DENSITY (P.C.F.)	MOISTURE CONTENT (%)
					ELEV. (MSL.) <u>324'</u>	DATE COMPLETED <u>02-23-2012</u>			
					EQUIPMENT <u>BACKHOE JD 455</u>		BY: <u>E. MILLER</u>		
MATERIAL DESCRIPTION									
0				SC	ALLUVIUM (Qal) Loose, damp to moist, light yellowish brown to dark brown, Clayey, fine to medium SAND to Gravelly fine to coarse SAND; few roots, subround to subangular gravel -Thinly to moderately bedded				
2									
4									
6				SW	OTAY FORMATION (Tog) Very dense, damp to moist, light yellowish brown, medium-to coarse -grained SANDSTONE; ("GRITSTONE") trace gravel up to 1" TRENCH TERMINATED AT 7 FEET No groundwater encountered				

Figure A-41,
Log of Trench T 22, Page 1 of 1

G1006-11-05.GPJ

SAMPLE SYMBOLS		... SAMPLING UNSUCCESSFUL		... STANDARD PENETRATION TEST		... DRIVE SAMPLE (UNDISTURBED)
		... DISTURBED OR BAG SAMPLE		... CHUNK SAMPLE		... WATER TABLE OR  ... SEEPAGE

NOTE: THE LOG OF SUBSURFACE CONDITIONS SHOWN HEREON APPLIES ONLY AT THE SPECIFIC BORING OR TRENCH LOCATION AND AT THE DATE INDICATED. IT IS NOT WARRANTED TO BE REPRESENTATIVE OF SUBSURFACE CONDITIONS AT OTHER LOCATIONS AND TIMES.









DEPTH IN FEET	SAMPLE NO.	LITHOLOGY	GROUNDWATER	SOIL CLASS (USCS)	TRENCH T 23		PENETRATION RESISTANCE (BLOWS/FT.)	DRY DENSITY (P.C.F.)	MOISTURE CONTENT (%)
					ELEV. (MSL.) <u>350'</u>	DATE COMPLETED <u>02-23-2012</u>			
					EQUIPMENT <u>BACKHOE JD 455</u>		BY: <u>E. MILLER</u>		
MATERIAL DESCRIPTION									
0				SC	TOPSOIL Medium dense, moist, dark brown, Clayey, fine to medium SAND; trace roots and rootlets				
2				SM	OTAY FORMATION (Tog) Very dense, dry, light yellowish brown, Silty, fine-to coarse-grained SANDSTONE; ("GRITSTONE") few gravel up to approximately 1/2"				
4					TRENCH TERMINATED AT 4 FEET No groundwater encountered				

Figure A-42,
Log of Trench T 23, Page 1 of 1

G1006-11-05.GPJ

SAMPLE SYMBOLS	 ... SAMPLING UNSUCCESSFUL	 ... STANDARD PENETRATION TEST	 ... DRIVE SAMPLE (UNDISTURBED)
	 ... DISTURBED OR BAG SAMPLE	 ... CHUNK SAMPLE	 ... WATER TABLE OR  ... SEEPAGE

NOTE: THE LOG OF SUBSURFACE CONDITIONS SHOWN HEREON APPLIES ONLY AT THE SPECIFIC BORING OR TRENCH LOCATION AND AT THE DATE INDICATED. IT IS NOT WARRANTED TO BE REPRESENTATIVE OF SUBSURFACE CONDITIONS AT OTHER LOCATIONS AND TIMES.









DEPTH IN FEET	SAMPLE NO.	LITHOLOGY	GROUNDWATER	SOIL CLASS (USCS)	TRENCH T 24		PENETRATION RESISTANCE (BLOWS/FT.)	DRY DENSITY (P.C.F.)	MOISTURE CONTENT (%)
					ELEV. (MSL.) <u>314'</u>	DATE COMPLETED <u>02-23-2012</u>			
					EQUIPMENT <u>BACKHOE JD 455</u>		BY: <u>E. MILLER</u>		
MATERIAL DESCRIPTION									
0				SC	ALLUVIUM (Qal) Loose, moist, dark brown to brown, Clayey, fine to coarse SAND; trace gravel				
2						-Becomes reddish brown			
4									
6	T24-1			SW	TERRACE DEPOSITS (Qt) Very dense, moist, brown to reddish brown, fine-to coarse-grained SANDSTONE; trace gravel up to 1"				
					TRENCH TERMINATED AT 7 FEET No groundwater encountered				

Figure A-43,
Log of Trench T 24, Page 1 of 1

G1006-11-05.GPJ

SAMPLE SYMBOLS		... SAMPLING UNSUCCESSFUL		... STANDARD PENETRATION TEST		... DRIVE SAMPLE (UNDISTURBED)
		... DISTURBED OR BAG SAMPLE		... CHUNK SAMPLE		... WATER TABLE OR  ... SEEPAGE

NOTE: THE LOG OF SUBSURFACE CONDITIONS SHOWN HEREON APPLIES ONLY AT THE SPECIFIC BORING OR TRENCH LOCATION AND AT THE DATE INDICATED. IT IS NOT WARRANTED TO BE REPRESENTATIVE OF SUBSURFACE CONDITIONS AT OTHER LOCATIONS AND TIMES.









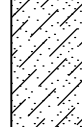

DEPTH IN FEET	SAMPLE NO.	LITHOLOGY	GROUNDWATER	SOIL CLASS (USCS)	TRENCH T 25		PENETRATION RESISTANCE (BLOWS/FT.)	DRY DENSITY (P.C.F.)	MOISTURE CONTENT (%)
					ELEV. (MSL.) <u>315'</u>	DATE COMPLETED <u>02-23-2012</u>			
					EQUIPMENT <u>BACKHOE JD 455</u>		BY: <u>E. MILLER</u>		
MATERIAL DESCRIPTION									
0				SC	TOPSOIL Medium dense, moist, dark brown, Clayey, fine to medium SAND; trace gravel up to approximately 2" -Becomes brown				
2				SM	TERRACE DEPOSITS (Qt) Dense, dry, reddish brown, fine-to medium-grained SANDSTONE				
4				SW	Very dense, damp, reddish brown, Silty, fine-to coarse-grained SANDSTONE; trace subrounded cobble up to approximately 5"				
6	T25-1								
					TRENCH TERMINATED AT 7 FEET No groundwater encountered				

Figure A-44,
Log of Trench T 25, Page 1 of 1

G1006-11-05.GPJ

SAMPLE SYMBOLS		... SAMPLING UNSUCCESSFUL		... STANDARD PENETRATION TEST		... DRIVE SAMPLE (UNDISTURBED)
		... DISTURBED OR BAG SAMPLE		... CHUNK SAMPLE		... WATER TABLE OR  ... SEEPAGE

NOTE: THE LOG OF SUBSURFACE CONDITIONS SHOWN HEREON APPLIES ONLY AT THE SPECIFIC BORING OR TRENCH LOCATION AND AT THE DATE INDICATED. IT IS NOT WARRANTED TO BE REPRESENTATIVE OF SUBSURFACE CONDITIONS AT OTHER LOCATIONS AND TIMES.







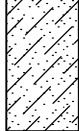
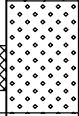

DEPTH IN FEET	SAMPLE NO.	LITHOLOGY	GROUNDWATER	SOIL CLASS (USCS)	TRENCH T 26		PENETRATION RESISTANCE (BLOWS/FT.)	DRY DENSITY (P.C.F.)	MOISTURE CONTENT (%)
					ELEV. (MSL.) <u>310'</u>	DATE COMPLETED <u>02-23-2012</u>			
					EQUIPMENT <u>BACKHOE JD 455</u> BY: <u>E. MILLER</u>				
MATERIAL DESCRIPTION									
0				SC	TOPSOIL Medium dense, moist, dark brown, Clayey, fine to medium SAND; trace subangular cobble up to 5"				
2									
4	T26-1			SW	TERRACE DEPOSITS (Qt) Very dense, moist, dark reddish brown, fine-to coarse-grained SANDSTONE; trace clay and subrounded gravel up to 2", subangular cobbles up to 5"				
					TRENCH TERMINATED AT 5.5 FEET No groundwater encountered				

Figure A-45,
Log of Trench T 26, Page 1 of 1

G1006-11-05.GPJ

SAMPLE SYMBOLS	 ... SAMPLING UNSUCCESSFUL	 ... STANDARD PENETRATION TEST	 ... DRIVE SAMPLE (UNDISTURBED)
	 ... DISTURBED OR BAG SAMPLE	 ... CHUNK SAMPLE	 ... WATER TABLE OR  ... SEEPAGE

NOTE: THE LOG OF SUBSURFACE CONDITIONS SHOWN HEREON APPLIES ONLY AT THE SPECIFIC BORING OR TRENCH LOCATION AND AT THE DATE INDICATED. IT IS NOT WARRANTED TO BE REPRESENTATIVE OF SUBSURFACE CONDITIONS AT OTHER LOCATIONS AND TIMES.









DEPTH IN FEET	SAMPLE NO.	LITHOLOGY	GROUNDWATER	SOIL CLASS (USCS)	TRENCH T 27		PENETRATION RESISTANCE (BLOWS/FT.)	DRY DENSITY (P.C.F.)	MOISTURE CONTENT (%)
					ELEV. (MSL.) <u>370'</u>	DATE COMPLETED <u>02-23-2012</u>			
					EQUIPMENT <u>BACKHOE JD 455</u>		BY: <u>E. MILLER</u>		
MATERIAL DESCRIPTION									
0				SC	TOPSOIL Medium dense, moist, dark brown, Clayey, fine to medium SAND				
2						-Trace carbonates			
4				SM	OTAY FORMATION (Tog) Very dense, damp, light yellowish brown, Silty, fine-to coarse-grained SANDSTONE; ("GRITSTONE") slightly cemented; trace gravel 1"				
						TRENCH TERMINATED AT 5 FEET No groundwater encountered			

Figure A-46,
Log of Trench T 27, Page 1 of 1

G1006-11-05.GPJ

SAMPLE SYMBOLS		... SAMPLING UNSUCCESSFUL		... STANDARD PENETRATION TEST		... DRIVE SAMPLE (UNDISTURBED)
		... DISTURBED OR BAG SAMPLE		... CHUNK SAMPLE		... WATER TABLE OR  ... SEEPAGE

NOTE: THE LOG OF SUBSURFACE CONDITIONS SHOWN HEREON APPLIES ONLY AT THE SPECIFIC BORING OR TRENCH LOCATION AND AT THE DATE INDICATED. IT IS NOT WARRANTED TO BE REPRESENTATIVE OF SUBSURFACE CONDITIONS AT OTHER LOCATIONS AND TIMES.









DEPTH IN FEET	SAMPLE NO.	LITHOLOGY	GROUNDWATER	SOIL CLASS (USCS)	TRENCH T 28		PENETRATION RESISTANCE (BLOWS/FT.)	DRY DENSITY (P.C.F.)	MOISTURE CONTENT (%)
					ELEV. (MSL.) <u>336'</u>	DATE COMPLETED <u>02-23-2012</u>			
					EQUIPMENT <u>BACKHOE JD 455</u> BY: <u>E. MILLER</u>				
					MATERIAL DESCRIPTION				
0				SC	TOPSOIL Medium dense, moist, dark brown, Clayey, fine to medium SAND				
2									
4				SM	-Trace carbonates OTAY FORMATION (Tog) Very dense, damp, light grayish brown to yellowish brown, Silty, fine-to coarse-grained SANDSTONE; ("GRITSTONE") trace gravel up to approximately 1"				
						TRENCH TERMINATED AT 5 FEET No groundwater encountered			

Figure A-47,
Log of Trench T 28, Page 1 of 1

G1006-11-05.GPJ

SAMPLE SYMBOLS	 ... SAMPLING UNSUCCESSFUL	 ... STANDARD PENETRATION TEST	 ... DRIVE SAMPLE (UNDISTURBED)
	 ... DISTURBED OR BAG SAMPLE	 ... CHUNK SAMPLE	 ... WATER TABLE OR  ... SEEPAGE

NOTE: THE LOG OF SUBSURFACE CONDITIONS SHOWN HEREON APPLIES ONLY AT THE SPECIFIC BORING OR TRENCH LOCATION AND AT THE DATE INDICATED. IT IS NOT WARRANTED TO BE REPRESENTATIVE OF SUBSURFACE CONDITIONS AT OTHER LOCATIONS AND TIMES.









DEPTH IN FEET	SAMPLE NO.	LITHOLOGY	GROUNDWATER	SOIL CLASS (USCS)	TRENCH T 29		PENETRATION RESISTANCE (BLOWS/FT.)	DRY DENSITY (P.C.F.)	MOISTURE CONTENT (%)
					ELEV. (MSL.) <u>235'</u>	DATE COMPLETED <u>02-23-2012</u>			
					EQUIPMENT <u>BACKHOE JD 455</u>		BY: <u>E. MILLER</u>		
MATERIAL DESCRIPTION									
0				SC	ALLUVIUM (Qal) Loose, dry to damp, dark brown, Clayey, fine to medium SAND				
2									
4						-Becomes moist, Clayey, fine to medium SAND; cobbles ranging from approximately 3" to approximately 18"			
6									
8									
10				SM	TERRACE DEPOSITS (Qt) Very dense, damp to moist, light grayish brown, Silty, fine-to coarse-grained SANDSTONE; trace gravel				
12						TRENCH TERMINATED AT 12 FEET No groundwater encountered			

Figure A-48,
Log of Trench T 29, Page 1 of 1

G1006-11-05.GPJ

SAMPLE SYMBOLS		... SAMPLING UNSUCCESSFUL		... STANDARD PENETRATION TEST		... DRIVE SAMPLE (UNDISTURBED)
		... DISTURBED OR BAG SAMPLE		... CHUNK SAMPLE		... WATER TABLE OR  ... SEEPAGE

NOTE: THE LOG OF SUBSURFACE CONDITIONS SHOWN HEREON APPLIES ONLY AT THE SPECIFIC BORING OR TRENCH LOCATION AND AT THE DATE INDICATED. IT IS NOT WARRANTED TO BE REPRESENTATIVE OF SUBSURFACE CONDITIONS AT OTHER LOCATIONS AND TIMES.

DEPTH IN FEET	SAMPLE NO.	LITHOLOGY	GROUNDWATER	SOIL CLASS (USCS)	TRENCH T 30		PENETRATION RESISTANCE (BLOWS/FT.)	DRY DENSITY (P.C.F.)	MOISTURE CONTENT (%)
					ELEV. (MSL.) <u>219'</u>	DATE COMPLETED <u>02-24-2012</u>			
					EQUIPMENT <u>BACKHOE JD 455</u>		BY: <u>A. GASTELUM</u>		
MATERIAL DESCRIPTION									
0	T30-1			SC	ALLUVIUM (Qal) Medium dense, moist, dark brown, Clayey, fine to coarse SAND; trace gravel				
2				SC	Medium dense, damp, dark brown, Clayey, fine to coarse SAND; trace gravel				
4									
6				SC	TERRACE DEPOSITS (Qt) Dense, moist, reddish brown, Clayey, medium-to coarse-grained SANDSTONE; trace gravel and cobbles up to 18" maximum dimension				
8									
10									
12									
14									
16									
					TRENCH TERMINATED AT 17.5 FEET No groundwater encountered				

Figure A-49,
Log of Trench T 30, Page 1 of 1

G1006-11-05.GPJ







SAMPLE SYMBOLS	... SAMPLING UNSUCCESSFUL	... STANDARD PENETRATION TEST	... DRIVE SAMPLE (UNDISTURBED)
	... DISTURBED OR BAG SAMPLE	... CHUNK SAMPLE	... WATER TABLE OR ... SEEPAGE

NOTE: THE LOG OF SUBSURFACE CONDITIONS SHOWN HEREON APPLIES ONLY AT THE SPECIFIC BORING OR TRENCH LOCATION AND AT THE DATE INDICATED. IT IS NOT WARRANTED TO BE REPRESENTATIVE OF SUBSURFACE CONDITIONS AT OTHER LOCATIONS AND TIMES.

DEPTH IN FEET	SAMPLE NO.	LITHOLOGY	GROUNDWATER	SOIL CLASS (USCS)	TRENCH T 31		PENETRATION RESISTANCE (BLOWS/FT.)	DRY DENSITY (P.C.F.)	MOISTURE CONTENT (%)
					ELEV. (MSL.) <u>223'</u>	DATE COMPLETED <u>02-24-2012</u>			
					EQUIPMENT <u>BACKHOE JD 455</u>		BY: <u>A. GASTELUM</u>		
MATERIAL DESCRIPTION									
0				SC	ALLUVIUM (Qal) Medium dense, dry, dark grayish brown, Clayey, fine to medium SAND				
2									
4				SC	TERRACE DEPOSITS (Qt) Desne to very dense, moist, reddish brown to grayish brown, Clayey, fine-to coarse-grained SANDSTONE; trace gravel and cobble; angular to rounded cobble up to 12"				
6									
8	T31-1								
10									
12	T31-2								
14									
16					-Becomes wet, dark reddish brown				
18									
					TRENCH TERMINATED AT 19 FEET No groundwater encountered				

Figure A-50,
Log of Trench T 31, Page 1 of 1

G1006-11-05.GPJ

SAMPLE SYMBOLS	 ... SAMPLING UNSUCCESSFUL	 ... STANDARD PENETRATION TEST	 ... DRIVE SAMPLE (UNDISTURBED)
	 ... DISTURBED OR BAG SAMPLE	 ... CHUNK SAMPLE	 ... WATER TABLE OR  ... SEEPAGE

NOTE: THE LOG OF SUBSURFACE CONDITIONS SHOWN HEREON APPLIES ONLY AT THE SPECIFIC BORING OR TRENCH LOCATION AND AT THE DATE INDICATED. IT IS NOT WARRANTED TO BE REPRESENTATIVE OF SUBSURFACE CONDITIONS AT OTHER LOCATIONS AND TIMES.

DEPTH IN FEET	SAMPLE NO.	LITHOLOGY	GROUNDWATER	SOIL CLASS (USCS)	TRENCH T 32		PENETRATION RESISTANCE (BLOWS/FT.)	DRY DENSITY (P.C.F.)	MOISTURE CONTENT (%)
					ELEV. (MSL.) <u>227'</u>	DATE COMPLETED <u>02-24-2012</u>			
					EQUIPMENT <u>BACKHOE JD 455</u>		BY: <u>A. GASTELUM</u>		
MATERIAL DESCRIPTION									
0	T32-1			SM	ALLUVIUM (Qal) Loose, damp, grayish brown, Silty, fine to medium SAND				
2				SC	TERRACE DEPOSITS (Qt) Medium dense, damp, brown to reddish brown, Clayey, fine-to coarse-grained SANDSTONE; little gravel and rounded to angular cobble up to 12"				
4				SC	Dense, moist, reddish brown, Clayey, fine-to coarse-grained SANDSTONE; little gravel and cobble; trace boulders up to 18"				
6									
8									
10									
12				SC	Dense, moist, reddish brown, Clayey, fine-to coarse-grained SANDSTONE; little gravel and cobble; trace boulders up to 18"				
14									
16					-Becomes grayish brown				
18					TRENCH TERMINATED AT 18 FEET No groundwater encountered				

Figure A-51,
Log of Trench T 32, Page 1 of 1

G1006-11-05.GPJ







SAMPLE SYMBOLS		... SAMPLING UNSUCCESSFUL		... STANDARD PENETRATION TEST		... DRIVE SAMPLE (UNDISTURBED)
		... DISTURBED OR BAG SAMPLE		... CHUNK SAMPLE		... WATER TABLE OR ... SEEPAGE

NOTE: THE LOG OF SUBSURFACE CONDITIONS SHOWN HEREON APPLIES ONLY AT THE SPECIFIC BORING OR TRENCH LOCATION AND AT THE DATE INDICATED. IT IS NOT WARRANTED TO BE REPRESENTATIVE OF SUBSURFACE CONDITIONS AT OTHER LOCATIONS AND TIMES.

DEPTH IN FEET	SAMPLE NO.	LITHOLOGY	GROUNDWATER	SOIL CLASS (USCS)	TRENCH T 33		PENETRATION RESISTANCE (BLOWS/FT.)	DRY DENSITY (P.C.F.)	MOISTURE CONTENT (%)
					ELEV. (MSL.) <u>214'</u>	DATE COMPLETED <u>02-24-2012</u>			
					EQUIPMENT <u>BACKHOE JD 455</u>		BY: <u>A. GASTELUM</u>		
MATERIAL DESCRIPTION									
0				CL	ALLUVIUM (Qal) Loose to medium dense, damp, dark grayish brown, fine to medium Sandy CLAY; trace cobbles				
2									
4				CL	TERRACE DEPOSITS (Qt) Dense to very dense, moist, reddish brown, Clayey fine-to coarse-grained SANDSTONE; little gravel and cobbles up to 18"				
6									
8									
10									
12									
14	T33-1			ML	Dense to very dense, moist, pale light grayish brown, Silty, medium-to coarse-grained SANDSTONE; little gravel, trace cobble and boulders up to 24", cemented				
16	T33-2								
18					TRENCH TERMINATED AT 18 FEET No groundwater encountered				

Figure A-52,
Log of Trench T 33, Page 1 of 1

G1006-11-05.GPJ

SAMPLE SYMBOLS	 ... SAMPLING UNSUCCESSFUL	 ... STANDARD PENETRATION TEST	 ... DRIVE SAMPLE (UNDISTURBED)
	 ... DISTURBED OR BAG SAMPLE	 ... CHUNK SAMPLE	 ... WATER TABLE OR  ... SEEPAGE

NOTE: THE LOG OF SUBSURFACE CONDITIONS SHOWN HEREON APPLIES ONLY AT THE SPECIFIC BORING OR TRENCH LOCATION AND AT THE DATE INDICATED. IT IS NOT WARRANTED TO BE REPRESENTATIVE OF SUBSURFACE CONDITIONS AT OTHER LOCATIONS AND TIMES.

DEPTH IN FEET	SAMPLE NO.	LITHOLOGY	GROUNDWATER	SOIL CLASS (USCS)	TRENCH T 34		PENETRATION RESISTANCE (BLOWS/FT.)	DRY DENSITY (P.C.F.)	MOISTURE CONTENT (%)	
					ELEV. (MSL.) <u>420'</u>	DATE COMPLETED <u>02-27-2012</u>				
					EQUIPMENT <u>BACKHOE JD 455</u> BY: <u>A. GASTELUM</u>					
					MATERIAL DESCRIPTION					
0				SM	TOPSOIL Medium dense, dry, dark brown, Silty, fine SAND; few rootlets					
2										
4				SM	OTAY FORMATION (To) Dense, dry, light yellowish brown, Silty, fine-to medium-grained SANDSTONE; trace gravel, weakly cemented					
6										
8						-Strongly cemented				
					TRENCH TERMINATED AT 9.5 FEET No groundwater encountered					

Figure A-53,
Log of Trench T 34, Page 1 of 1

G1006-11-05.GPJ

SAMPLE SYMBOLS		... SAMPLING UNSUCCESSFUL		... STANDARD PENETRATION TEST		... DRIVE SAMPLE (UNDISTURBED)
		... DISTURBED OR BAG SAMPLE		... CHUNK SAMPLE		... WATER TABLE OR ... SEEPAGE

NOTE: THE LOG OF SUBSURFACE CONDITIONS SHOWN HEREON APPLIES ONLY AT THE SPECIFIC BORING OR TRENCH LOCATION AND AT THE DATE INDICATED. IT IS NOT WARRANTED TO BE REPRESENTATIVE OF SUBSURFACE CONDITIONS AT OTHER LOCATIONS AND TIMES.

DEPTH IN FEET	SAMPLE NO.	LITHOLOGY	GROUNDWATER	SOIL CLASS (USCS)	TRENCH T 35		PENETRATION RESISTANCE (BLOWS/FT.)	DRY DENSITY (P.C.F.)	MOISTURE CONTENT (%)
					ELEV. (MSL.) <u>430'</u>	DATE COMPLETED <u>02-27-2012</u>			
					EQUIPMENT <u>BACKHOE JD 455</u>		BY: <u>E. MILLER</u>		
MATERIAL DESCRIPTION									
0				SM	ALLUVIUM (Qal) Loose, damp, dark brown, Silty, fine SAND				
2									
4				SM	OTAY FORMATION (To) Dense to very dense, dry, light yellowish brown, Silty, fine-to medium-grained SANDSTONE; trace gravel, moderately cemented				
6						TRENCH TERMINATED AT 6.5 FEET No groundwater encountered			

Figure A-54,
Log of Trench T 35, Page 1 of 1

G1006-11-05.GPJ

SAMPLE SYMBOLS		... SAMPLING UNSUCCESSFUL		... STANDARD PENETRATION TEST		... DRIVE SAMPLE (UNDISTURBED)
		... DISTURBED OR BAG SAMPLE		... CHUNK SAMPLE		... WATER TABLE OR ... SEEPAGE

NOTE: THE LOG OF SUBSURFACE CONDITIONS SHOWN HEREON APPLIES ONLY AT THE SPECIFIC BORING OR TRENCH LOCATION AND AT THE DATE INDICATED. IT IS NOT WARRANTED TO BE REPRESENTATIVE OF SUBSURFACE CONDITIONS AT OTHER LOCATIONS AND TIMES.

DEPTH IN FEET	SAMPLE NO.	LITHOLOGY	GROUNDWATER	SOIL CLASS (USCS)	TRENCH T 36		PENETRATION RESISTANCE (BLOWS/FT.)	DRY DENSITY (P.C.F.)	MOISTURE CONTENT (%)
					ELEV. (MSL.) <u>472'</u>	DATE COMPLETED <u>02-27-2012</u>			
					EQUIPMENT <u>BACKHOE JD 455</u> BY: <u>E. MILLER</u>				
MATERIAL DESCRIPTION									
0				SM	ALLUVIUM (Qal) Loose, damp, dark brown, Silty, fine SAND; few rootlets				
2									
4				SM	OTAY FORMATION (To) Dense, dry, light yellowish brown, Silty, fine SANDSTONE; strongly cemented				
6						TRENCH TERMINATED AT 6 FEET No groundwater encountered			

Figure A-55,
Log of Trench T 36, Page 1 of 1

G1006-11-05.GPJ

SAMPLE SYMBOLS		... SAMPLING UNSUCCESSFUL		... STANDARD PENETRATION TEST		... DRIVE SAMPLE (UNDISTURBED)
		... DISTURBED OR BAG SAMPLE		... CHUNK SAMPLE		... WATER TABLE OR ... SEEPAGE

NOTE: THE LOG OF SUBSURFACE CONDITIONS SHOWN HEREON APPLIES ONLY AT THE SPECIFIC BORING OR TRENCH LOCATION AND AT THE DATE INDICATED. IT IS NOT WARRANTED TO BE REPRESENTATIVE OF SUBSURFACE CONDITIONS AT OTHER LOCATIONS AND TIMES.







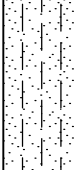

DEPTH IN FEET	SAMPLE NO.	LITHOLOGY	GROUNDWATER	SOIL CLASS (USCS)	TRENCH T 37		PENETRATION RESISTANCE (BLOWS/FT.)	DRY DENSITY (P.C.F.)	MOISTURE CONTENT (%)
					ELEV. (MSL.) <u>508'</u>	DATE COMPLETED <u>02-27-2012</u>			
					EQUIPMENT <u>BACKHOE JD 455</u>		BY: <u>E. MILLER</u>		
MATERIAL DESCRIPTION									
0				SM	ALLUVIUM (Qal) Loose, dry, dark brown, Silty, fine SAND; few rootlets				
2									
4				SW	OTAY FORMATION (To) Dense, dry, light yellowish brown, fine-to medium-grained SANDSTONE; moderately cemented				
6									
					TRENCH TERMINATED AT 7 FEET No groundwater encountered				

Figure A-56,
Log of Trench T 37, Page 1 of 1

G1006-11-05.GPJ

SAMPLE SYMBOLS		... SAMPLING UNSUCCESSFUL		... STANDARD PENETRATION TEST		... DRIVE SAMPLE (UNDISTURBED)
		... DISTURBED OR BAG SAMPLE		... CHUNK SAMPLE		... WATER TABLE OR  ... SEEPAGE

NOTE: THE LOG OF SUBSURFACE CONDITIONS SHOWN HEREON APPLIES ONLY AT THE SPECIFIC BORING OR TRENCH LOCATION AND AT THE DATE INDICATED. IT IS NOT WARRANTED TO BE REPRESENTATIVE OF SUBSURFACE CONDITIONS AT OTHER LOCATIONS AND TIMES.











DEPTH IN FEET	SAMPLE NO.	LITHOLOGY	GROUNDWATER	SOIL CLASS (USCS)	TRENCH T 38		PENETRATION RESISTANCE (BLOWS/FT.)	DRY DENSITY (P.C.F.)	MOISTURE CONTENT (%)
					ELEV. (MSL.) <u>546'</u>	DATE COMPLETED <u>02-27-2012</u>			
					EQUIPMENT <u>BACKHOE JD 455</u>		BY: <u>E. MILLER</u>		
MATERIAL DESCRIPTION									
0				SM	TOPSOIL Loose, dry, dark brown, Silty, fine SAND; few rootlets				
2				SM	OTAY FORMATION (To) Dense, dry, light yellowish brown, Silty, fine SANDSTONE; strongly cemented, krotovinas to about 3 feet				
4				CL	Stiff, grayish brown, Silty CLAYSTONE				
6									
8				SM	Dense, dry, light yellowish brown, Silty, fine SANDSTONE				
					TRENCH TERMINATED AT 9.5 FEET No groundwater encountered				

Figure A-57,
Log of Trench T 38, Page 1 of 1

G1006-11-05.GPJ







SAMPLE SYMBOLS	 ... SAMPLING UNSUCCESSFUL	 ... STANDARD PENETRATION TEST	 ... DRIVE SAMPLE (UNDISTURBED)
	 ... DISTURBED OR BAG SAMPLE	 ... CHUNK SAMPLE	 ... WATER TABLE OR  ... SEEPAGE

NOTE: THE LOG OF SUBSURFACE CONDITIONS SHOWN HEREON APPLIES ONLY AT THE SPECIFIC BORING OR TRENCH LOCATION AND AT THE DATE INDICATED. IT IS NOT WARRANTED TO BE REPRESENTATIVE OF SUBSURFACE CONDITIONS AT OTHER LOCATIONS AND TIMES.

DEPTH IN FEET	SAMPLE NO.	LITHOLOGY	GROUNDWATER	SOIL CLASS (USCS)	TRENCH T 39		PENETRATION RESISTANCE (BLOWS/FT.)	DRY DENSITY (P.C.F.)	MOISTURE CONTENT (%)
					ELEV. (MSL.) <u>356'</u>	DATE COMPLETED <u>02-27-2012</u>			
					EQUIPMENT <u>BACKHOE JD 455</u>		BY: <u>E. MILLER</u>		
MATERIAL DESCRIPTION									
0				SM	ALLUVIUM (Qal) Loose, damp, brown, Silty, fine to medium SAND; few rootlets, trace carbonates and trace subangular gravel up to approximately 3"				
2					-Medium dense, dark brown, Silty, fine to coarse SAND; few rootlets				
4									
6									
8	T39-1			SM	OTAY FORMATION (Tog) Dense to very dense, damp, yellowish brown, Silty, fine-to coarse-grained SANDSTONE; ("GRITSTONE") trace clay and gravel up to 3"				
10					-No gravel				
					TRENCH TERMINATED AT 11 FEET No groundwater encountered				

Figure A-58,
Log of Trench T 39, Page 1 of 1

G1006-11-05.GPJ

SAMPLE SYMBOLS	 ... SAMPLING UNSUCCESSFUL	 ... STANDARD PENETRATION TEST	 ... DRIVE SAMPLE (UNDISTURBED)
	 ... DISTURBED OR BAG SAMPLE	 ... CHUNK SAMPLE	 ... WATER TABLE OR  ... SEEPAGE

NOTE: THE LOG OF SUBSURFACE CONDITIONS SHOWN HEREON APPLIES ONLY AT THE SPECIFIC BORING OR TRENCH LOCATION AND AT THE DATE INDICATED. IT IS NOT WARRANTED TO BE REPRESENTATIVE OF SUBSURFACE CONDITIONS AT OTHER LOCATIONS AND TIMES.

DEPTH IN FEET	SAMPLE NO.	LITHOLOGY	GROUNDWATER	SOIL CLASS (USCS)	TRENCH T 40		PENETRATION RESISTANCE (BLOWS/FT.)	DRY DENSITY (P.C.F.)	MOISTURE CONTENT (%)	
					ELEV. (MSL.) <u>420'</u>	DATE COMPLETED <u>02-27-2012</u>				
					EQUIPMENT <u>BACKHOE JD 455</u>		BY: <u>E. MILLER</u>			
MATERIAL DESCRIPTION										
0				SM	TOPSOIL Loose, damp, dark brown, Silty, fine to medium SAND					
2			ML	OTAY FORMATION (To) Hard, damp, whitish brown, fine-grained Sandy SILTSTONE						
4			SM	Very dense, damp, light gray, Silty, fine-grained SANDSTONE; massive						
6										
8										
10										
12										
					TRENCH TERMINATED AT 12.5 FEET No groundwater encountered					

Figure A-59,
Log of Trench T 40, Page 1 of 1

G1006-11-05.GPJ

SAMPLE SYMBOLS	... SAMPLING UNSUCCESSFUL	... STANDARD PENETRATION TEST	... DRIVE SAMPLE (UNDISTURBED)
	... DISTURBED OR BAG SAMPLE	... CHUNK SAMPLE	... WATER TABLE OR ... SEEPAGE

NOTE: THE LOG OF SUBSURFACE CONDITIONS SHOWN HEREON APPLIES ONLY AT THE SPECIFIC BORING OR TRENCH LOCATION AND AT THE DATE INDICATED. IT IS NOT WARRANTED TO BE REPRESENTATIVE OF SUBSURFACE CONDITIONS AT OTHER LOCATIONS AND TIMES.

DEPTH IN FEET	SAMPLE NO.	LITHOLOGY	GROUNDWATER	SOIL CLASS (USCS)	TRENCH T 41		PENETRATION RESISTANCE (BLOWS/FT.)	DRY DENSITY (P.C.F.)	MOISTURE CONTENT (%)
					ELEV. (MSL.) <u>426'</u>	DATE COMPLETED <u>02-27-2012</u>			
					EQUIPMENT <u>BACKHOE JD 455</u>		BY: <u>E. MILLER</u>		
MATERIAL DESCRIPTION									
0	T41-1			SM	TOPSOIL Loose, damp, dark brown, Silty, fine SAND; rootlets				
2			ML	OTAY FORMATION (To) Stiff, dry, light grayish brown, fine-grained Sandy SILTSTONE					
4			CH	Stiff, damp, brown, Silty CLAYSTONE; bentonite, approximately 3" thick					
6			ML	Stiff, dry, light grayish brown, fine-grained Sandy SILTSTONE					
					TRENCH TERMINATED AT 7 FEET No groundwater encountered				

Figure A-60,
Log of Trench T 41, Page 1 of 1

G1006-11-05.GPJ

SAMPLE SYMBOLS		... SAMPLING UNSUCCESSFUL		... STANDARD PENETRATION TEST		... DRIVE SAMPLE (UNDISTURBED)
		... DISTURBED OR BAG SAMPLE		... CHUNK SAMPLE		... WATER TABLE OR ... SEEPAGE

NOTE: THE LOG OF SUBSURFACE CONDITIONS SHOWN HEREON APPLIES ONLY AT THE SPECIFIC BORING OR TRENCH LOCATION AND AT THE DATE INDICATED. IT IS NOT WARRANTED TO BE REPRESENTATIVE OF SUBSURFACE CONDITIONS AT OTHER LOCATIONS AND TIMES.







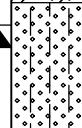
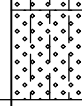

DEPTH IN FEET	SAMPLE NO.	LITHOLOGY	GROUNDWATER	SOIL CLASS (USCS)	TRENCH T 42		PENETRATION RESISTANCE (BLOWS/FT.)	DRY DENSITY (P.C.F.)	MOISTURE CONTENT (%)
					ELEV. (MSL.) <u>334'</u>	DATE COMPLETED <u>08-28-2012</u>			
					EQUIPMENT <u>JD 555</u> BY: <u>M. ERTWINE</u>				
MATERIAL DESCRIPTION									
0	T42-1			SC	TOPSOIL Stiff, moist, dark brown, Sandy CLAY				
2				SM	TERRACE DEPOSIT (Qt) Dense, moist to damp, light reddish brown, Silty, fine-to medium-grained SANDSTONE, trace clay and subrounded cobbles				
4				SM	OTAY FORMATION (Tog) Dense to very dense, damp, light grayish brown, fine-to coarse-grained Silty SANDSTONE ("Gritstone") -Abundant carbonates to about 6' -Becomes slightly cemented				
6					TRENCH TERMINATED AT 6.5 FEET No groundwater encountered				

Figure A-61,
Log of Trench T 42, Page 1 of 1

G1006-11-05.GPJ

SAMPLE SYMBOLS		... SAMPLING UNSUCCESSFUL		... STANDARD PENETRATION TEST		... DRIVE SAMPLE (UNDISTURBED)
		... DISTURBED OR BAG SAMPLE		... CHUNK SAMPLE		... WATER TABLE OR  ... SEEPAGE

NOTE: THE LOG OF SUBSURFACE CONDITIONS SHOWN HEREON APPLIES ONLY AT THE SPECIFIC BORING OR TRENCH LOCATION AND AT THE DATE INDICATED. IT IS NOT WARRANTED TO BE REPRESENTATIVE OF SUBSURFACE CONDITIONS AT OTHER LOCATIONS AND TIMES.











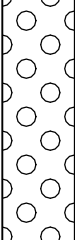

DEPTH IN FEET	SAMPLE NO.	LITHOLOGY	GROUNDWATER	SOIL CLASS (USCS)	TRENCH T 43		PENETRATION RESISTANCE (BLOWS/FT.)	DRY DENSITY (P.C.F.)	MOISTURE CONTENT (%)
					ELEV. (MSL.) <u>432'</u>	DATE COMPLETED <u>08-28-2012</u>			
					EQUIPMENT <u>JD 555</u>		BY: <u>M. ERTWINE</u>		
MATERIAL DESCRIPTION									
0				SC	TOPSOIL Medium dense, moist, dark brown, Clayey, fine-to coarse SAND, trace rootlets				
2				GP	-Abundant cobble within 2 feet				
4					TERRACE DEPOSITS (Qt) Dense, damp, reddish brown, Sandy CONGLOMERATE; pockets of grayish brown, fine to coarse sand				
6					-Abundant cobble up to 4" in maximum dimension				
8				SM	-Locally slight cemented Very dense, damp, reddish brown, Silty, medium to-coarse grained SANDSTONE				
10				SM	-Some subangular gravel and cobble OTAY FORMATION (Tog) Very dense, damp, light yellowish brown, fine-to coarse-grained SANDSTONE; ("Gritstone"), slightly cemented				
14					TRENCH TERMINATED AT 14 FEET No groundwater encountered				

Figure A-62,
Log of Trench T 43, Page 1 of 1

G1006-11-05.GPJ

SAMPLE SYMBOLS		... SAMPLING UNSUCCESSFUL		... STANDARD PENETRATION TEST		... DRIVE SAMPLE (UNDISTURBED)
		... DISTURBED OR BAG SAMPLE		... CHUNK SAMPLE		... WATER TABLE OR  ... SEEPAGE

NOTE: THE LOG OF SUBSURFACE CONDITIONS SHOWN HEREON APPLIES ONLY AT THE SPECIFIC BORING OR TRENCH LOCATION AND AT THE DATE INDICATED. IT IS NOT WARRANTED TO BE REPRESENTATIVE OF SUBSURFACE CONDITIONS AT OTHER LOCATIONS AND TIMES.









DEPTH IN FEET	SAMPLE NO.	LITHOLOGY	GROUNDWATER	SOIL CLASS (USCS)	TRENCH T 44		PENETRATION RESISTANCE (BLOWS/FT.)	DRY DENSITY (P.C.F.)	MOISTURE CONTENT (%)
					ELEV. (MSL.) <u>348'</u>	DATE COMPLETED <u>08-28-2012</u>			
					EQUIPMENT <u>JD 555</u> BY: <u>M. ERTWINE</u>				
					MATERIAL DESCRIPTION				
0				SC	TOPSOIL Loose, moist, brown, Clayey SAND				
2				SM	OTAY FORMATION (Tog) Highly weathered, medium dense, damp, whitish, Silty, fine-to coarse-grained SANDSTONE; abundant carbonates				
4					TRENCH TERMINATED AT 4.5 FEET No groundwater encountered				

Figure A-63,
Log of Trench T 44, Page 1 of 1

G1006-11-05.GPJ

SAMPLE SYMBOLS	 ... SAMPLING UNSUCCESSFUL	 ... STANDARD PENETRATION TEST	 ... DRIVE SAMPLE (UNDISTURBED)
	 ... DISTURBED OR BAG SAMPLE	 ... CHUNK SAMPLE	 ... WATER TABLE OR  ... SEEPAGE

NOTE: THE LOG OF SUBSURFACE CONDITIONS SHOWN HEREON APPLIES ONLY AT THE SPECIFIC BORING OR TRENCH LOCATION AND AT THE DATE INDICATED. IT IS NOT WARRANTED TO BE REPRESENTATIVE OF SUBSURFACE CONDITIONS AT OTHER LOCATIONS AND TIMES.









DEPTH IN FEET	SAMPLE NO.	LITHOLOGY	GROUNDWATER	SOIL CLASS (USCS)	TRENCH T 45		PENETRATION RESISTANCE (BLOWS/FT.)	DRY DENSITY (P.C.F.)	MOISTURE CONTENT (%)
					ELEV. (MSL.) <u>336'</u>	DATE COMPLETED <u>08-28-2012</u>			
					EQUIPMENT <u>JD 555</u> BY: <u>M. ERTWINE</u>				
MATERIAL DESCRIPTION									
0				SC	TOPSOIL Loose, moist, brown, Clayey SAND				
2				SM	OTAY FORMATION (Tog) Highly weathered, Silty, medium- to coarse-grained SANDSTONE; slightly cemented				
					TRENCH TERMINATED AT 3 FEET No groundwater encountered				

Figure A-64,
Log of Trench T 45, Page 1 of 1

G1006-11-05.GPJ

SAMPLE SYMBOLS	 ... SAMPLING UNSUCCESSFUL	 ... STANDARD PENETRATION TEST	 ... DRIVE SAMPLE (UNDISTURBED)
	 ... DISTURBED OR BAG SAMPLE	 ... CHUNK SAMPLE	 ... WATER TABLE OR  ... SEEPAGE

NOTE: THE LOG OF SUBSURFACE CONDITIONS SHOWN HEREON APPLIES ONLY AT THE SPECIFIC BORING OR TRENCH LOCATION AND AT THE DATE INDICATED. IT IS NOT WARRANTED TO BE REPRESENTATIVE OF SUBSURFACE CONDITIONS AT OTHER LOCATIONS AND TIMES.

DEPTH IN FEET	SAMPLE NO.	LITHOLOGY	GROUNDWATER	SOIL CLASS (USCS)	TRENCH T 46		PENETRATION RESISTANCE (BLOWS/FT.)	DRY DENSITY (P.C.F.)	MOISTURE CONTENT (%)
					ELEV. (MSL.) <u>324'</u>	DATE COMPLETED <u>08-28-2012</u>			
					EQUIPMENT <u>JD 555</u>		BY: <u>M. ERTWINE</u>		
MATERIAL DESCRIPTION									
0				SC	TOPSOIL Loose, moist, brown, Clayey, fine to medium SAND				
2	T46-1			SM	TERRACE DEPOSITS (Qt) Dense, moist, grayish brown, fine- to medium-grained SANDSTONE; highly weathered; friable; pebble sized gravel				
4				SM	Dense, moist, grayish brown, fine- to medium-grained SANDSTONE, weakly cemented				
6	T46-2								
8				SM-GP	Dense, damp, moist, reddish brown, Clayey SANDSTONE to CONGLOMERATE; approximately 20% to 30% cobble up to 4" diameter				
10									
12									
14									
					TRENCH TERMINATED AT 14 FEET No groundwater encountered				

Figure A-65,
Log of Trench T 46, Page 1 of 1

G1006-11-05.GPJ

SAMPLE SYMBOLS	... SAMPLING UNSUCCESSFUL	... STANDARD PENETRATION TEST	... DRIVE SAMPLE (UNDISTURBED)
	... DISTURBED OR BAG SAMPLE	... CHUNK SAMPLE	... WATER TABLE OR ... SEEPAGE

NOTE: THE LOG OF SUBSURFACE CONDITIONS SHOWN HEREON APPLIES ONLY AT THE SPECIFIC BORING OR TRENCH LOCATION AND AT THE DATE INDICATED. IT IS NOT WARRANTED TO BE REPRESENTATIVE OF SUBSURFACE CONDITIONS AT OTHER LOCATIONS AND TIMES.

DEPTH IN FEET	SAMPLE NO.	LITHOLOGY	GROUNDWATER	SOIL CLASS (USCS)	TRENCH T 47		PENETRATION RESISTANCE (BLOWS/FT.)	DRY DENSITY (P.C.F.)	MOISTURE CONTENT (%)
					ELEV. (MSL.) <u>334'</u>	DATE COMPLETED <u>08-28-2012</u>			
					EQUIPMENT <u>JD 555</u> BY: <u>M. ERTWINE</u>				
					MATERIAL DESCRIPTION				
0				SC	TOPSOIL Medium dense, moist, brown, Clayey, fine to medium SAND				
2	T47-1			SC	TERRACE DEPOSITS (Qt) Stiff, moist, reddish brown, Sandy CLAY; common parting surfaces and blocky texture -Trace cobble				
4	T47-2			SM	OTAY FORMATION (Tog) Highly weathered, medium dense, moist, light grayish brown, Silty, fine-to coarse -grained SANDSTONE; trace pinhole porosity				
6				SM	Dense, moist, light grayish to reddish brown, Silty, medium-to coarse-grained SANDSTONE ("Gritstone") slightly cemented				
8	T47-3				TRENCH TERMINATED AT 8 FEET No groundwater encountered				

Figure A-66,
Log of Trench T 47, Page 1 of 1

G1006-11-05.GPJ

SAMPLE SYMBOLS		... SAMPLING UNSUCCESSFUL		... STANDARD PENETRATION TEST		... DRIVE SAMPLE (UNDISTURBED)
		... DISTURBED OR BAG SAMPLE		... CHUNK SAMPLE		... WATER TABLE OR ... SEEPAGE

NOTE: THE LOG OF SUBSURFACE CONDITIONS SHOWN HEREON APPLIES ONLY AT THE SPECIFIC BORING OR TRENCH LOCATION AND AT THE DATE INDICATED. IT IS NOT WARRANTED TO BE REPRESENTATIVE OF SUBSURFACE CONDITIONS AT OTHER LOCATIONS AND TIMES.









DEPTH IN FEET	SAMPLE NO.	LITHOLOGY	GROUNDWATER	SOIL CLASS (USCS)	TRENCH T 48		PENETRATION RESISTANCE (BLOWS/FT.)	DRY DENSITY (P.C.F.)	MOISTURE CONTENT (%)
					ELEV. (MSL.) <u>340'</u>	DATE COMPLETED <u>08-28-2012</u>			
					EQUIPMENT <u>JD 555</u> BY: <u>M. ERTWINE</u>				
MATERIAL DESCRIPTION									
0				SC	TOPSOIL Medium dense, moist, brown, Clayey, fine to medium SAND				
2				SM	OTAY FORMATION (Tog) Dense, damp, grayish brown, Silty, fine-to coarse-grained SANDSTONE; ("Gritstone"); slightly cemented				
4					TRENCH TERMINATED AT 4 FEET No groundwater encountered				

Figure A-67,
Log of Trench T 48, Page 1 of 1

G1006-11-05.GPJ

SAMPLE SYMBOLS	 ... SAMPLING UNSUCCESSFUL	 ... STANDARD PENETRATION TEST	 ... DRIVE SAMPLE (UNDISTURBED)
	 ... DISTURBED OR BAG SAMPLE	 ... CHUNK SAMPLE	 ... WATER TABLE OR  ... SEEPAGE

NOTE: THE LOG OF SUBSURFACE CONDITIONS SHOWN HEREON APPLIES ONLY AT THE SPECIFIC BORING OR TRENCH LOCATION AND AT THE DATE INDICATED. IT IS NOT WARRANTED TO BE REPRESENTATIVE OF SUBSURFACE CONDITIONS AT OTHER LOCATIONS AND TIMES.









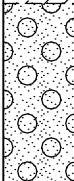

DEPTH IN FEET	SAMPLE NO.	LITHOLOGY	GROUNDWATER	SOIL CLASS (USCS)	TRENCH T 49		PENETRATION RESISTANCE (BLOWS/FT.)	DRY DENSITY (P.C.F.)	MOISTURE CONTENT (%)
					ELEV. (MSL.) <u>328'</u>	DATE COMPLETED <u>08-29-2012</u>			
					EQUIPMENT <u>JD 555</u> BY: <u>M. ERTWINE</u>				
MATERIAL DESCRIPTION									
0				SC	TOPSOIL Stiff, moist, brown, Sandy CLAY				
2				SC	TERRACE DEPOSITS (Qt) Medium dense, moist, reddish brown, Clayey, fine to medium-grained SANDSTONE; trace pinhole porosity to approximately 8 feet -Trace of carbonates and cobble -Some burrows -Becomes dense				
4									
6									
8									
10				SM-GP	Very dense, damp, reddish to gray brown, Silty, fine-to coarse SANDSTONE to CONGLOMERATE; weakly cemented -Approximately. 10% to 20% cobble and becomes moderately cemented				
12									
14					TRENCH TERMINATED AT 14 FEET No groundwater encountered				

Figure A-68,
Log of Trench T 49, Page 1 of 1

G1006-11-05.GPJ

SAMPLE SYMBOLS	 ... SAMPLING UNSUCCESSFUL	 ... STANDARD PENETRATION TEST	 ... DRIVE SAMPLE (UNDISTURBED)
	 ... DISTURBED OR BAG SAMPLE	 ... CHUNK SAMPLE	 ... WATER TABLE OR  ... SEEPAGE

NOTE: THE LOG OF SUBSURFACE CONDITIONS SHOWN HEREON APPLIES ONLY AT THE SPECIFIC BORING OR TRENCH LOCATION AND AT THE DATE INDICATED. IT IS NOT WARRANTED TO BE REPRESENTATIVE OF SUBSURFACE CONDITIONS AT OTHER LOCATIONS AND TIMES.

DEPTH IN FEET	SAMPLE NO.	LITHOLOGY	GROUNDWATER	SOIL CLASS (USCS)	TRENCH T 50		PENETRATION RESISTANCE (BLOWS/FT.)	DRY DENSITY (P.C.F.)	MOISTURE CONTENT (%)
					ELEV. (MSL.) <u>209'</u>	DATE COMPLETED <u>08-29-2012</u>			
					EQUIPMENT <u>JD 555</u>		BY: <u>M. ERTWINE</u>		
MATERIAL DESCRIPTION									
0	T50-1			SC	ALLUVIUM (Qal) Stiff, dark reddish brown, Clayey, fine-to medium grained SAND; trace rootlets and subrounded cobble -Becomes reddish-brown with manganese oxide staining and trace pinhole porosity				
2				SM	TERRACE DEPOSITS (Qt) Dense, moist, reddish brown, Clayey, fine-to medium grained SANDSTONE; little cobble and trace gravel				
4				GP	Very dense, damp, reddish brown, Sandy CONGLOMERATE, with pockets of light brown, fine-to medium SAND -Approximately. 20% to 30% cobble, difficult excavations -Trench belling				
6									
8									
10					TRENCH TERMINATED AT 10 FEET No groundwater encountered				

Figure A-69,
Log of Trench T 50, Page 1 of 1

G1006-11-05.GPJ

SAMPLE SYMBOLS	... SAMPLING UNSUCCESSFUL	... STANDARD PENETRATION TEST	... DRIVE SAMPLE (UNDISTURBED)
	... DISTURBED OR BAG SAMPLE	... CHUNK SAMPLE	... WATER TABLE OR ... SEEPAGE

NOTE: THE LOG OF SUBSURFACE CONDITIONS SHOWN HEREON APPLIES ONLY AT THE SPECIFIC BORING OR TRENCH LOCATION AND AT THE DATE INDICATED. IT IS NOT WARRANTED TO BE REPRESENTATIVE OF SUBSURFACE CONDITIONS AT OTHER LOCATIONS AND TIMES.

DEPTH IN FEET	SAMPLE NO.	LITHOLOGY	GROUNDWATER	SOIL CLASS (USCS)	TRENCH T 51		PENETRATION RESISTANCE (BLOWS/FT.)	DRY DENSITY (P.C.F.)	MOISTURE CONTENT (%)
					ELEV. (MSL.) <u>205'</u>	DATE COMPLETED <u>08-29-2012</u>			
					EQUIPMENT <u>JD 555</u> BY: <u>M. ERTWINE</u>				
MATERIAL DESCRIPTION									
0				SC	ALLUVIUM (Qal) Stiff, moist, dark, reddish brown, Sandy CLAY; trace rootlets and subrounded cobble				
2									
4				SM-GP	TERRACE DEPOSIT (Qt) Very dense, reddish brown, Silty SANDSTONE to Conglomerate				
					REFUSAL AT 4 FEET No groundwater encountered				

Figure A-70,
Log of Trench T 51, Page 1 of 1

G1006-11-05.GPJ

SAMPLE SYMBOLS	... SAMPLING UNSUCCESSFUL	... STANDARD PENETRATION TEST	... DRIVE SAMPLE (UNDISTURBED)
	... DISTURBED OR BAG SAMPLE	... CHUNK SAMPLE	... WATER TABLE OR ... SEEPAGE

NOTE: THE LOG OF SUBSURFACE CONDITIONS SHOWN HEREON APPLIES ONLY AT THE SPECIFIC BORING OR TRENCH LOCATION AND AT THE DATE INDICATED. IT IS NOT WARRANTED TO BE REPRESENTATIVE OF SUBSURFACE CONDITIONS AT OTHER LOCATIONS AND TIMES.

DEPTH IN FEET	SAMPLE NO.	LITHOLOGY	GROUNDWATER	SOIL CLASS (USCS)	TRENCH T 52		PENETRATION RESISTANCE (BLOWS/FT.)	DRY DENSITY (P.C.F.)	MOISTURE CONTENT (%)
					ELEV. (MSL.) <u>210'</u>	DATE COMPLETED <u>08-29-2012</u>			
					EQUIPMENT <u>JD 555</u> BY: <u>M. ERTWINE</u>				
MATERIAL DESCRIPTION									
0				SM	ALLUVIUM (Qal) Medium dense, moist, light grayish brown, Silty, fine to medium SAND; trace carbonates -Becomes dense				
2									
4									
6				GP	TERRACE DEPOSIT (Qt) Very dense, moist, reddish brown, fine to coarse Sandy CONGLOMERATE; approximately 20% to 30% cobble; moderately weakly cemented TRENCH TERMINATED AT 6 FEET No groundwater encountered				

Figure A-71,
Log of Trench T 52, Page 1 of 1

G1006-11-05.GPJ

SAMPLE SYMBOLS	... SAMPLING UNSUCCESSFUL	... STANDARD PENETRATION TEST	... DRIVE SAMPLE (UNDISTURBED)
	... DISTURBED OR BAG SAMPLE	... CHUNK SAMPLE	... WATER TABLE OR ... SEEPAGE

NOTE: THE LOG OF SUBSURFACE CONDITIONS SHOWN HEREON APPLIES ONLY AT THE SPECIFIC BORING OR TRENCH LOCATION AND AT THE DATE INDICATED. IT IS NOT WARRANTED TO BE REPRESENTATIVE OF SUBSURFACE CONDITIONS AT OTHER LOCATIONS AND TIMES.

DEPTH IN FEET	SAMPLE NO.	LITHOLOGY	GROUNDWATER	SOIL CLASS (USCS)	TRENCH T 53		PENETRATION RESISTANCE (BLOWS/FT.)	DRY DENSITY (P.C.F.)	MOISTURE CONTENT (%)
					ELEV. (MSL.) <u>214'</u>	DATE COMPLETED <u>08-29-2012</u>			
					EQUIPMENT <u>JD 555</u> BY: <u>M. ERTWINE</u>				
MATERIAL DESCRIPTION									
0				SC	ALLUVIUM (Qal) Medium dense, moist, olive brown to brown, Clayey, fine to medium SAND				
2				GP	TERRACE DEPOSIT (Qt) Very dense, moist, reddish brown, fine to coarse Sandy CONGLOMERATE; approximately 20% to 30% cobble; moderately weakly cemented				
					REFUSAL AT 3 FEET No groundwater encountered				

Figure A-72,
Log of Trench T 53, Page 1 of 1

G1006-11-05.GPJ

SAMPLE SYMBOLS		... SAMPLING UNSUCCESSFUL		... STANDARD PENETRATION TEST		... DRIVE SAMPLE (UNDISTURBED)
		... DISTURBED OR BAG SAMPLE		... CHUNK SAMPLE		... WATER TABLE OR ... SEEPAGE

NOTE: THE LOG OF SUBSURFACE CONDITIONS SHOWN HEREON APPLIES ONLY AT THE SPECIFIC BORING OR TRENCH LOCATION AND AT THE DATE INDICATED. IT IS NOT WARRANTED TO BE REPRESENTATIVE OF SUBSURFACE CONDITIONS AT OTHER LOCATIONS AND TIMES.

DEPTH IN FEET	SAMPLE NO.	LITHOLOGY	GROUNDWATER	SOIL CLASS (USCS)	TRENCH T 54		PENETRATION RESISTANCE (BLOWS/FT.)	DRY DENSITY (P.C.F.)	MOISTURE CONTENT (%)
					ELEV. (MSL.) <u>220'</u>	DATE COMPLETED <u>08-29-2012</u>			
					EQUIPMENT <u>JD 555</u>		BY: <u>M. ERTWINE</u>		
MATERIAL DESCRIPTION									
0				SM	ALLUVIUM (Qal) Firm, moist, brown, Sandy, fine to medium SAND; trace rootlets and gravel				
2									
4					SC	TERRACE DEPOSIT (Qt) Medium dense, moist, reddish brown, Clayey, fine-to medium-grained SANDSTONE; friable, trace pinhole, porosity			
6									
8				GP	Very dense, damp, reddish brown, Sandy CONGLOMERATE; with pockets of silty sand, moderately cemented				
					TRENCH TERMINATED AT 9 FEET No groundwater encountered				

Figure A-73,
Log of Trench T 54, Page 1 of 1

G1006-11-05.GPJ

SAMPLE SYMBOLS	... SAMPLING UNSUCCESSFUL	... STANDARD PENETRATION TEST	... DRIVE SAMPLE (UNDISTURBED)
	... DISTURBED OR BAG SAMPLE	... CHUNK SAMPLE	... WATER TABLE OR ... SEEPAGE

NOTE: THE LOG OF SUBSURFACE CONDITIONS SHOWN HEREON APPLIES ONLY AT THE SPECIFIC BORING OR TRENCH LOCATION AND AT THE DATE INDICATED. IT IS NOT WARRANTED TO BE REPRESENTATIVE OF SUBSURFACE CONDITIONS AT OTHER LOCATIONS AND TIMES.

DEPTH IN FEET	SAMPLE NO.	LITHOLOGY	GROUNDWATER	SOIL CLASS (USCS)	TRENCH T 55		PENETRATION RESISTANCE (BLOWS/FT.)	DRY DENSITY (P.C.F.)	MOISTURE CONTENT (%)
					ELEV. (MSL.) <u>222'</u>	DATE COMPLETED <u>08-29-2012</u>			
					EQUIPMENT <u>JD 555</u> BY: <u>M. ERTWINE</u>				
					MATERIAL DESCRIPTION				
0				SC	ALLUVIUM (Qal) Medium dense, moist, reddish brown, Clayey, fine to coarse SAND				
2				SC	Stiff, moist, brown, Sandy CLAY; trace pinhole porosity and burrows				
4				GP	TERRACE DEPOSIT (Qt) Dense to very dense, reddish brown, Sandy CONGLOMERATE; pockets of silty sand; approximately 20%-30% cobble				
					REFUSAL AT 5 FEET No groundwater encountered				

Figure A-74,
Log of Trench T 55, Page 1 of 1

G1006-11-05.GPJ







SAMPLE SYMBOLS	... SAMPLING UNSUCCESSFUL	... STANDARD PENETRATION TEST	... DRIVE SAMPLE (UNDISTURBED)
	... DISTURBED OR BAG SAMPLE	... CHUNK SAMPLE	... WATER TABLE OR ... SEEPAGE

NOTE: THE LOG OF SUBSURFACE CONDITIONS SHOWN HEREON APPLIES ONLY AT THE SPECIFIC BORING OR TRENCH LOCATION AND AT THE DATE INDICATED. IT IS NOT WARRANTED TO BE REPRESENTATIVE OF SUBSURFACE CONDITIONS AT OTHER LOCATIONS AND TIMES.

DEPTH IN FEET	SAMPLE NO.	LITHOLOGY	GROUNDWATER	SOIL CLASS (USCS)	TRENCH T 56		PENETRATION RESISTANCE (BLOWS/FT.)	DRY DENSITY (P.C.F.)	MOISTURE CONTENT (%)
					ELEV. (MSL.) <u>230'</u>	DATE COMPLETED <u>08-29-2012</u>			
					EQUIPMENT <u>JD 555</u> BY: <u>M. ERTWINE</u>				
MATERIAL DESCRIPTION									
0				SM	TOPSOIL Loose, dry, grayish, brown, Silty SAND; abundant rootlets and burrows				
2									
4	T56-1			SC	TERRACE DEPOSIT (Qt) Stiff, moist, reddish brown, Sandy CLAY; abundant carbonates stringers				
6									
8				SM	Dense, moist, reddish brown, fine-to coarse-grained SANDSTONE, approximately 10% cobble; trace boulders up to 12 inches				
10									
12				GP	Very dense, moist, reddish brown, CONGLOMERATE with pockets of silty sand				
14					TRENCH TERMINATED AT 14 FEET No groundwater encountered				

Figure A-75,
Log of Trench T 56, Page 1 of 1

G1006-11-05.GPJ

SAMPLE SYMBOLS	 ... SAMPLING UNSUCCESSFUL	 ... STANDARD PENETRATION TEST	 ... DRIVE SAMPLE (UNDISTURBED)
	 ... DISTURBED OR BAG SAMPLE	 ... CHUNK SAMPLE	 ... WATER TABLE OR  ... SEEPAGE

NOTE: THE LOG OF SUBSURFACE CONDITIONS SHOWN HEREON APPLIES ONLY AT THE SPECIFIC BORING OR TRENCH LOCATION AND AT THE DATE INDICATED. IT IS NOT WARRANTED TO BE REPRESENTATIVE OF SUBSURFACE CONDITIONS AT OTHER LOCATIONS AND TIMES.













DEPTH IN FEET	SAMPLE NO.	LITHOLOGY	GROUNDWATER	SOIL CLASS (USCS)	TRENCH T 57		PENETRATION RESISTANCE (BLOWS/FT.)	DRY DENSITY (P.C.F.)	MOISTURE CONTENT (%)
					ELEV. (MSL.) <u>237'</u>	DATE COMPLETED <u>08-29-2012</u>			
					EQUIPMENT <u>JD 555</u> BY: <u>M. ERTWINE</u>				
MATERIAL DESCRIPTION									
0				SM	TOPSOIL Medium dense, dry, light reddish brown, Silty, fine-to medium SAND; trace rootlets				
2				CL	TERRACE DEPOSIT (Qt) Stiff, moist, reddish brown, Sandy CLAY; abundant cobble				
4				GP	Very dense, reddish brown, Sandy CONGLOMERATE; pockets of silty sand				
6				SC	Very stiff, reddish brown, Sandy CLAY, trace subangular gravel				
	T57-1								
					TRENCH TERMINATED AT 7 FEET No groundwater encountered				

Figure A-76,
Log of Trench T 57, Page 1 of 1

G1006-11-05.GPJ

SAMPLE SYMBOLS		... SAMPLING UNSUCCESSFUL		... STANDARD PENETRATION TEST		... DRIVE SAMPLE (UNDISTURBED)
		... DISTURBED OR BAG SAMPLE		... CHUNK SAMPLE		... WATER TABLE OR  ... SEEPAGE

NOTE: THE LOG OF SUBSURFACE CONDITIONS SHOWN HEREON APPLIES ONLY AT THE SPECIFIC BORING OR TRENCH LOCATION AND AT THE DATE INDICATED. IT IS NOT WARRANTED TO BE REPRESENTATIVE OF SUBSURFACE CONDITIONS AT OTHER LOCATIONS AND TIMES.

APPENDIX

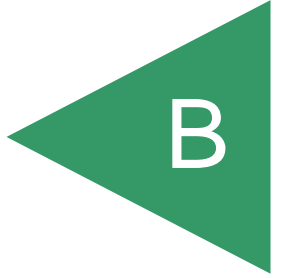

APPENDIX B

PREVIOUS LABORATORY TESTING

FOR

OTAY RANCH VILLAGE 8 WEST
CHULA VISTA, CALIFORNIA

PROJECT NO. G1006-52-05

APPENDIX B

PREVIOUS LABORATORY TESTING

We performed laboratory tests during our previous geotechnical investigation in accordance with generally accepted test methods of the American Society for Testing and Materials (ASTM) or other suggested procedures. Selected soil samples were analyzed for in-situ dry density and moisture content, maximum dry density and optimum moisture content, direct shear strength, expansion potential, water-soluble sulfate, Atterberg Limits, R-Value, and gradation. The results of the laboratory tests are presented on Tables B-I through B-VI and Figure B-1. The in-place dry density and moisture content of the samples tested are presented on the boring logs in Appendix A.

**TABLE B-I
SUMMARY OF LABORATORY MAXIMUM DRY DENSITY
AND OPTIMUM MOISTURE CONTENT TEST RESULTS
ASTM D 1557**

Sample No.	Description (Geologic Unit)	Maximum Dry Density (pcf)	Optimum Moisture Content (% dry wt.)
B1-1 (To)	Brown, Clayey SILT	114.1	16.3
B2-2 (To)	Brown, Silty, fine SAND	112.7	15.1
B7-3 (To)	Brown, Silty, fine SAND	116.2	13.8
T16-1 (Qal)	Dark gray, Silty CLAY with trace gravel	114.0	15.3
T30-1 (Qal)	Dark yellowish brown, Clayey, fine to medium SAND	134.5	7.7

**TABLE B-II
SUMMARY OF LABORATORY DIRECT SHEAR TEST RESULTS
ASTM D 3080**

Sample No. (Geologic Unit)	Dry Density (pcf)	Moisture Content (%)		Peak [Ultimate] Cohesion (psf)	Peak [Ultimate] Angle of Shear Resistance (degrees)
		Initial	After Test		
B1-6 (To)	111.1	13.9	22.3	185 [50]	41 [41]
B1-8 (To)	89.1	34.2	42.7	295 [0]	27 [29]
B2-2* (To)	103.2	12.7	25.8	120 [20]	29 [30]
B3-2 (To)	104.1	19.9	28.9	590 [165]	34 [36]
B3-5 (To)	108.3	15.1	24.9	650 [235]	32 [36]
B4-2 (To)	116.6	14.1	20.3	70 [0]	41 [40]
B7-3* (To)	103.6	14.6	21.7	335 [30]	28 [30]

*Sample remolded to a dry density of approximately 90 percent of the laboratory maximum dry density near optimum moisture content.

**TABLE B-III
SUMMARY OF LABORATORY EXPANSION INDEX TEST RESULTS
ASTM D 4829**

Sample No. (Geologic Unit)	Moisture Content (%)		Dry Density (pcf)	Expansion Index	Expansion Classification	2022 Expansion Classification
	Before Test	After Test				
B1-1 (To)	10.8	26.4	102.2	68	Medium	Expansive
B2-2 (To)	12.6	28.2	98.6	62	Medium	Expansive
T16-1 (Qal)	12.6	29.6	100.7	82	Medium	Expansive
T30-1 (Qal)	8.7	16.3	114.2	19	Very Low	Non-Expansive

**TABLE B-IV
SUMMARY OF LABORATORY WATER-SOLUBLE SULFATE TEST RESULTS
CALIFORNIA TEST NO. 417**

Sample No. (Geologic Unit)	Water-Soluble Sulfate (%)	Water-Soluble Sulfate (ppm)	ACI 318 Sulfate Exposure
B1-1 (To)	0.028	275	Not Applicable (S0)
B2-2 (To)	0.000	2	Not Applicable (S0)

**TABLE B-V
SUMMARY OF LABORATORY ATTERBERG LIMITS TEST RESULTS
ASTM D 4318**

Sample No. (Geologic Unit)	Liquid Limit	Plastic Limit	Plasticity Index
B1-9 (Tob)	77	37	40
B3-6 (To)	117	61	56
B9-2 (To)	105	51	54

**TABLE B-VI
SUMMARY OF LABORATORY RESISTANCE VALUE (R-VALUE) TEST RESULTS
ASTM D 2844**

Sample No. (Geologic Unit)	R-Value
B3-4 (To)	15

GRAVEL		SAND			SILT OR CLAY
COARSE	FINE	COARSE	MEDIUM	FINE	

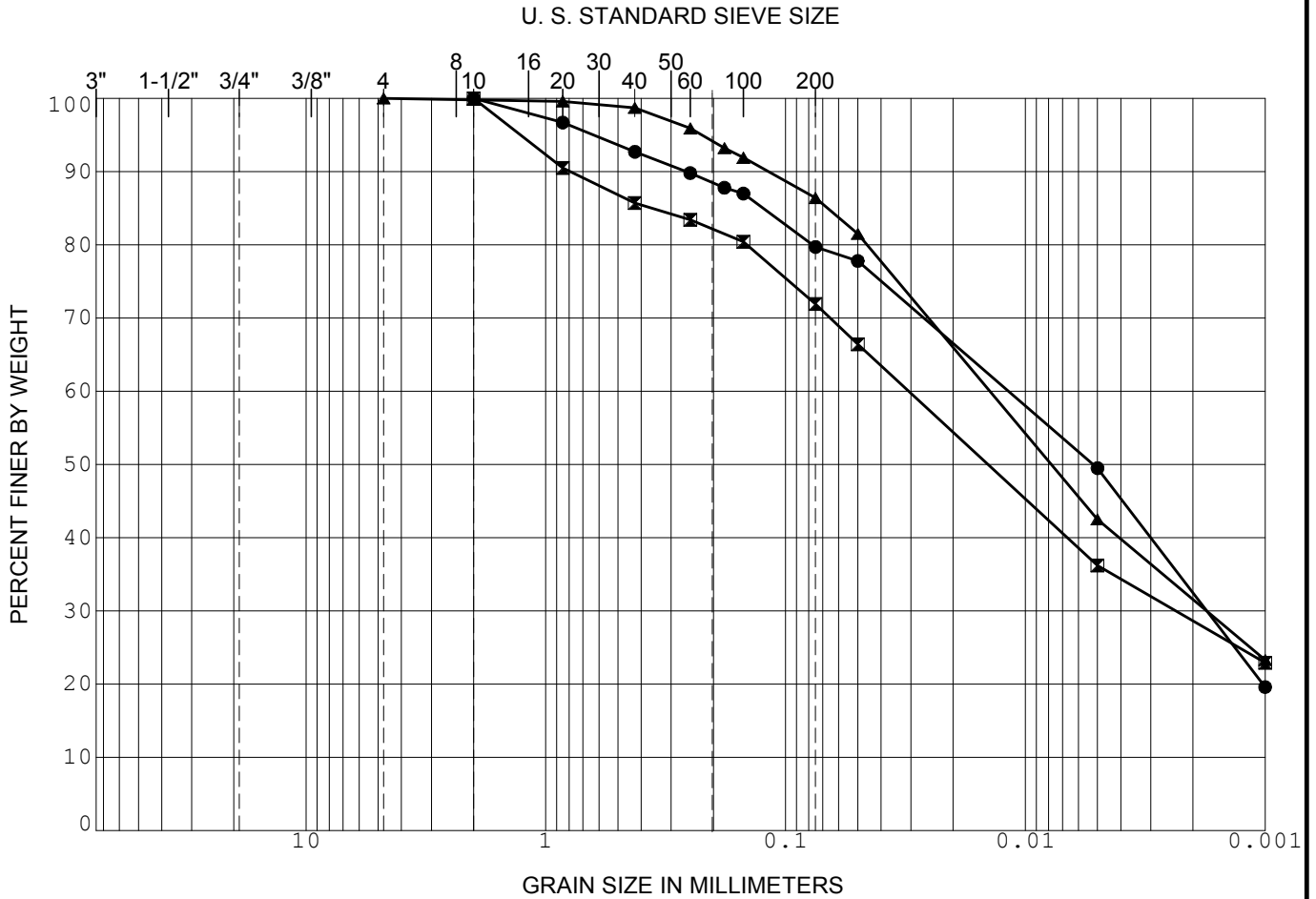

	SAMPLE	DEPTH (ft)	CLASSIFICATION	NAT WC	LL	PL	PI
●	B1-9	33.0	(MH) SILT		77	37	40
■	B3-6	30.0	(MH) SILT		117	61	56
▲	B9-2	18.0	(MH) SILT		105	51	54

GRADATION CURVE

OTAY RANCH VILLAGE 8
CHULA VISTA, CALIFORNIA

APPENDIX

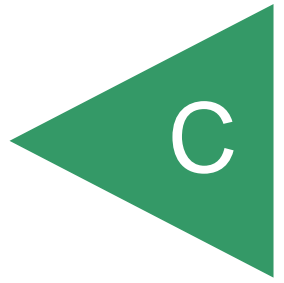

APPENDIX C

SLOPE STABILITY ANALYSES

We performed slope stability analyses using a two-dimensional computer program *GeoStudio2018* created by Geo-Slope International Ltd. We analyzed the critical modes of potential slip surfaces including rotational-mode and block-mode based on Spencer's method. The soil parameters used, case conditions, and the calculated factors of safety were presented herein. Plots of analyses' results, including the soil stratigraphy, potential failure surfaces, and calculated Factors of Safety, are included in this appendix.

We evaluated the shear strength parameters for the existing geologic features from laboratory direct shear and residual shear tests on samples obtained during our field investigation and on samples obtained from other investigations in the area in accordance with ASTM D 3080. We performed direct shear tests on samples of the Terrace Deposits, and the Otay Formation. The geologic units encountered and the shear strength properties used in the analyses is presented on Table C-I.

TABLE C-I
SUMMARY OF SOIL PROPERTIES USED FOR SLOPE STABILITY ANALYSES

Geologic Unit/Material	Density (pcf)	Cohesion (psf)	Friction Angle (degrees)
Compacted Fill (Qcf)	125	250	28
Otay Formation (To)	130	350	34
Otay Formation (Tog)	130	350	34
Otay Formation Bentonite	120	30	6

We selected Geologic Cross-Sections A-A' through H-H' to perform the slope stability analyses. Table C-II provides a summary of cases analyzed and calculated Factors of Safety. A minimum Factor of Safety of 1.5 under static conditions is currently required by the City of Chula Vista for slope stability. Figures C-1 through C-34 present the results of slope stability analyses generated by *GeoStudio 2018*. As discussed herein, we encountered claystone layers in several of the exploratory borings within the Otay Formation. The claystone possesses relatively low shear strengths and may be prone to slope instability if exposed in cut slopes. A factor of safety of 1.5 for all static slopes is currently required by the City of Chula Vista to build structures above or below a slope.

**TABLE C-II
SUMMARY OF SLOPE STABILITY ANALYSES**

Figure Number	Cross Section	Condition of Slope Stability Analyses	Calculated Factor of Safety
B-1	A-A'	MSE Wall: Geogrids = Miragrid 5XT spaced at 2 ft. intervals, Lengths=20 ft.; Fill behind face of wall = minimum 20 ft. wide at bottom; Block-mode analysis along bentonite, static condition	1.95
B-2	A-A'	MSE Wall: Geogrids = Miragrid 5XT spaced at 2 ft. intervals, Lengths=20 ft.; Fill behind face of wall = minimum 20 ft. wide at bottom; Block-mode analysis along upper bentonite behind fill, static condition	3.23
B-3	A-A'	MSE Wall: Geogrids = Miragrid 5XT spaced at 2 ft. intervals, Lengths=20 ft.; Fill behind face of wall = minimum 20 ft. wide at bottom; Rotational-mode analysis, static condition	1.63
B-4	B-B'	MSE Wall: Bottom 4 Geogrids = Miragrid 10XT & Upper Geogrids=Miragrid 8XT, spaced at 2 ft. intervals, Lengths=25 ft.; Fill behind face of wall = minimum 25 ft. wide at bottom; Rotational-mode analysis, static condition	1.55
B-5	B-B'	MSE Wall: Bottom 4 Geogrids = Miragrid 10XT & Upper Geogrids=Miragrid 8XT, spaced at 2 ft. intervals, Lengths=25 ft.; Fill behind face of wall = minimum 25 ft. wide at bottom; Block-mode analysis along bentonite behind wall, static condition	1.75
B-6	B-B'	MSE Wall: Bottom 4 Geogrids = Miragrid 10XT & Upper Geogrids=Miragrid 8XT, spaced at 2 ft. intervals, Lengths=25 ft.; Fill behind face of wall = minimum 25 ft. wide at bottom; Block-mode analysis along upper bentonite behind wall, static condition	2.10
B-7	B-B'	MSE Wall: Bottom 4 Geogrids = Miragrid 10XT & Upper Geogrids=Miragrid 8XT, spaced at 2 ft. intervals, Lengths=25 ft.; Fill behind face of wall = minimum 25 ft. wide at bottom; Block-mode analysis along bentonite below wall, static condition	1.97
B-8	C-C'	Upper Slope; Proposed Pad Undercut of bentonite in front of slope, Block-mode analysis along bentonite, static condition	1.80
B-9	C-C'	Upper Slope; Proposed Pad Undercut of bentonite in front of slope, Rotational-mode analysis, static condition	2.66
B-10	C-C'	Lower Slope; Rotational-mode analysis, static condition	2.07
B-11	D-D'	Upper Slope; Block-mode analysis along bentonite, static condition	1.22
B-12	D-D'	Upper Slope; 20 ft. wide buttress; Block-mode analysis along bentonite, static condition	1.53
B-13	D-D'	Upper Slope; 20 ft. wide buttress; Rotational-mode analysis, static condition	2.16
B-14	D-D'	Lower Slope; MSE Wall: Geogrids = Miragrid 5XT spaced at 2 ft. intervals, Lengths=10 ft.; Rotational-mode analysis, static condition	1.98
B-15	E-E'	MSE Wall: Geogrids = Miragrid 5XT spaced at 2 ft. intervals, Lengths = 8 ft.; Fill behind face of wall = minimum 8 ft. wide at bottom; Block-mode analysis along bentonite, static condition	1.34
B-16	E-E'	MSE Wall: Geogrids = Miragrid 5XT spaced at 2 ft. intervals, Lengths = 8 ft.; Minimum 30 ft. wide buttress behind face of wall at bottom; Block-mode analysis along bentonite, static condition	1.58

Figure Number	Cross Section	Condition of Slope Stability Analyses	Calculated Factor of Safety
B-17	E-E'	MSE Wall: Geogrids = Miragrid 5XT spaced at 2 ft. intervals, Lengths = 8 ft.; Minimum 30 ft. wide buttress behind face of wall at bottom; Rotational-mode analysis, static condition	1.69
B-18	F-F'	Lower slope; Block-mode analysis along lower bentonite, static condition	1.31
B-19	F-F'	Lower slope; 15 ft. wide buttress within limits of grading ; Block-mode analysis along lower bentonite, static condition	0.99
B-20	F-F'	Lower slope; 15 ft. wide buttress within limits of grading; Required Setback where Factor of Safety = 1.50 ; Block-mode analysis along lower bentonite, static condition	1.50
B-21	F-F'	Lower slope; 15 ft. wide buttress outside of limits of grading ; Block-mode analysis along lower bentonite, static condition	1.54
B-22	G-G'	Block-mode analysis along bentonite, static condition	1.89
B-23	G-G'	Rotational-mode analysis, static condition	3.48
B-24	H-H'	MSE Wall: Bottom 4 Geogrids = Miragrid 10XT & Upper Geogrids=Miragrid 8XT, spaced at 2 ft. intervals, Lengths=20 ft.; Fill behind face of wall = minimum 20 ft. wide at bottom; Rotational-mode analysis, static condition	1.54
B-25	H-H'	MSE Wall: Bottom 4 Geogrids = Miragrid 10XT & Upper Geogrids=Miragrid 8XT, spaced at 2 ft. intervals, Lengths=20 ft.; Fill behind face of wall = minimum 20 ft. wide at bottom; Block-mode analysis along bentonite below wall, static condition	2.31
B-26	H-H'	MSE Wall: Bottom 4 Geogrids = Miragrid 10XT & Upper Geogrids=Miragrid 8XT, spaced at 2 ft. intervals, Lengths=20 ft.; Fill behind face of wall = minimum 20 ft. wide at bottom; Block-mode analysis along lower bentonite behind wall, static condition	1.60
B-27	H-H'	MSE Wall: Bottom 4 Geogrids = Miragrid 10XT & Upper Geogrids=Miragrid 8XT, spaced at 2 ft. intervals, Lengths=20 ft.; Fill behind face of wall = minimum 20 ft. wide at bottom; Block-mode analysis along upper bentonite behind wall, static condition	1.73
B-28	H-H'	Slope at limits of grading; Block-mode analysis along lower bentonite, static condition	0.99
B-29	H-H'	Slope at limits of grading; Block-mode analysis along upper bentonite, static condition	0.31
B-30	H-H'	Slope at limits of grading; 20 ft. wide buttress; Block-mode analysis along lower bentonite, static condition	1.78
B-31	H-H'	Slope at limits of grading; 20 ft. wide buttress; Block-mode analysis along upper bentonite, static condition	2.12
B-32	H-H'	Slope at limits of grading; 20 ft. wide buttress; Rotational-mode analysis, static condition	1.94
B-33	N/A	2:1 fill slope, 50 feet high, rotational-mode analysis, static condition	1.67
B-34	N/A	2:1 cut slope, 45 feet high, rotational-mode analysis, static condition	2.22

Project Name: Otay Ranch Village 8
 Project No. G1006-52-05
 Section A-A'
 File Name: A-A'_Case1.gsz
 Date: 09/26/2022, Time: 09:17:56 AM

Proposed Grade
 Static Condition
 Block-mode Analysis Along Bentonite

Material Properties:

Color	Name	Unit Weight (pcf)	Cohesion' (psf)	Phi' (°)
Yellow	Qcf	125	250	28
Light Green	To	130	350	34
Red	Tob (bentonite)	120	30	6
Orange	Tog	130	350	34

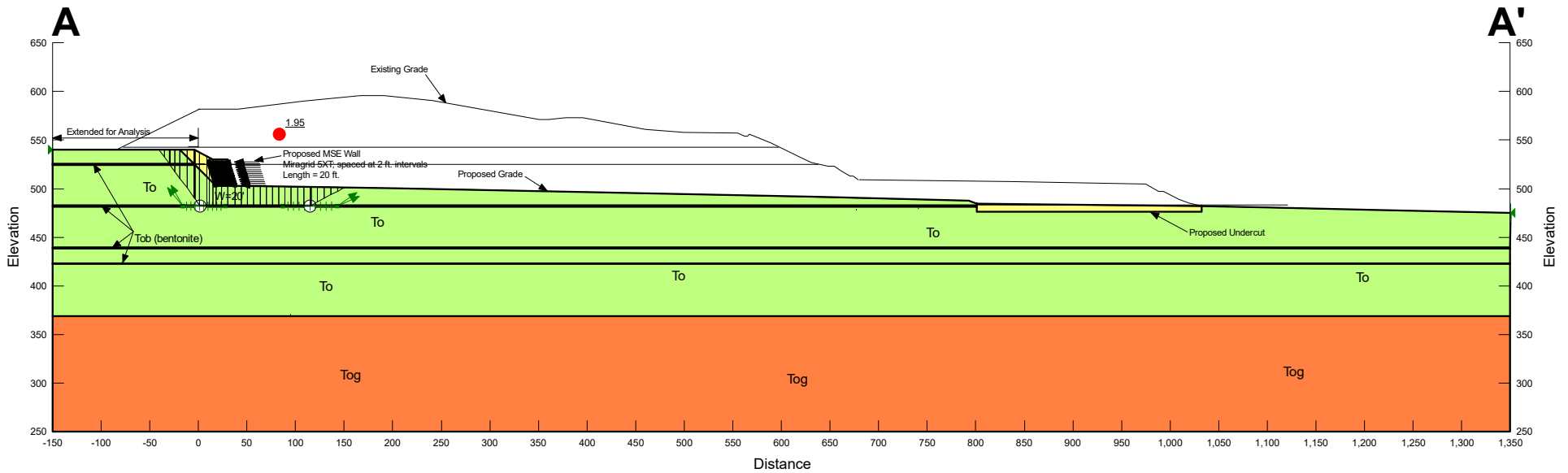

Project Name: Otay Ranch Village 8
 Project No. G1006-52-05
 Section A-A'
 File Name: A-A'_Case2.gsz
 Date: 09/26/2022, Time: 09:30:31 AM

Proposed Grade
 Static Condition
 Block-mode Analysis Along Bentonite

Material Properties:

Color	Name	Unit Weight (pcf)	Cohesion' (psf)	Phi' (°)
Yellow	Qcf	125	250	28
Light Green	To	130	350	34
Red	Tob (bentonite)	120	30	6
Orange	Tog	130	350	34

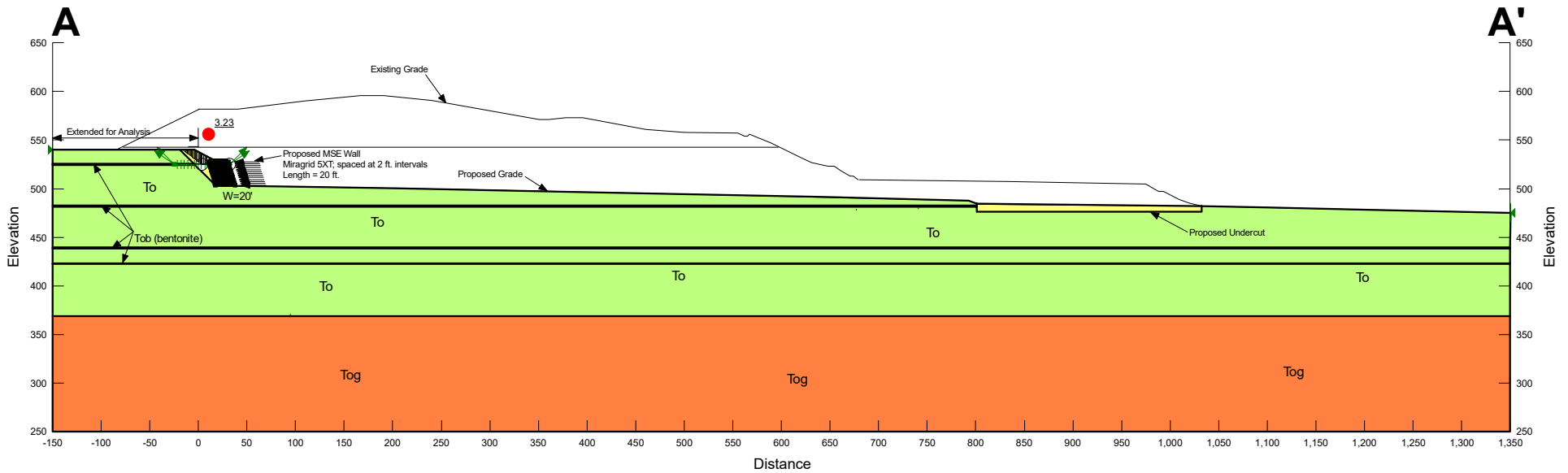

Project Name: Otay Ranch Village 8
 Project No. G1006-52-05
 Section A-A'
 File Name: A-A'_Case3.gsz
 Date: 09/26/2022, Time: 09:33:24 AM

Proposed Grade
 Static Condition
 Block-mode Analysis Along Bentonite

Material Properties:

Color	Name	Unit Weight (pcf)	Cohesion' (psf)	Phi' (°)
Yellow	Qcf	125	250	28
Light Green	To	130	350	34
Red	Tob (bentonite)	120	30	6
Orange	Tog	130	350	34

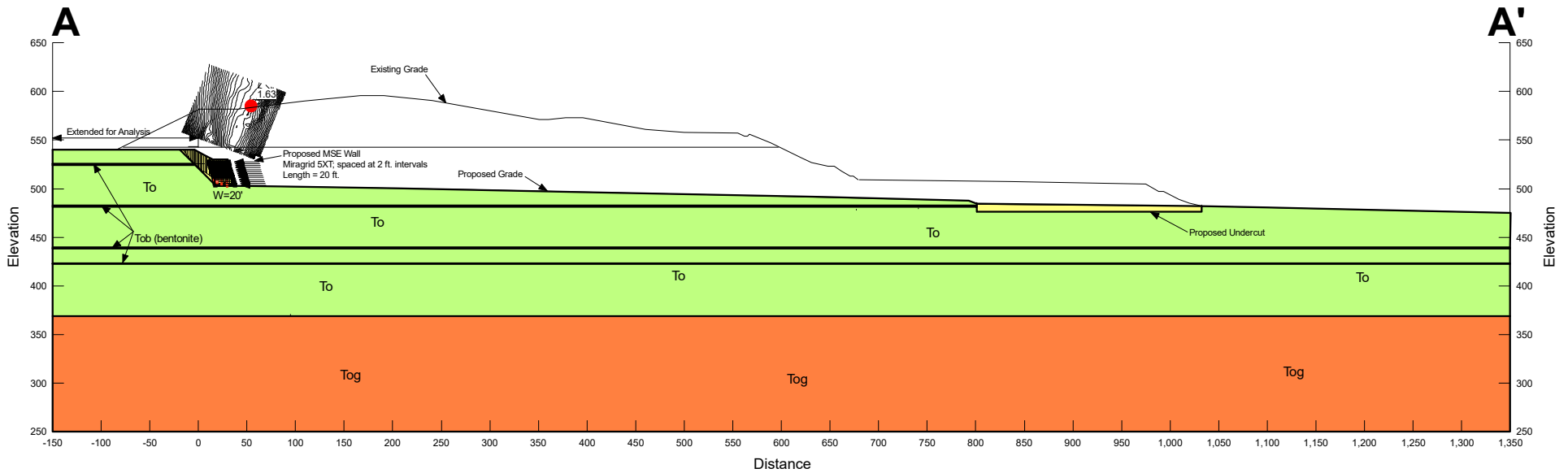

Project Name: Otay Ranch Village 8
 Project No. G1006-52-05
 Section B-B'
 File Name: B-B'_Case1a.gsz
 Date: 09/26/2022, Time: 09:43:30 AM

Proposed Grade
 Static Condition
 Rotational-mode Analysis

Material Properties:

Color	Name	Unit Weight (pcf)	Cohesion' (psf)	Phi' (°)
Yellow	Qcf	125	250	28
Light Green	To	130	350	34
Red	Tob (bentonite)	120	30	6
Orange	Tog	130	350	34

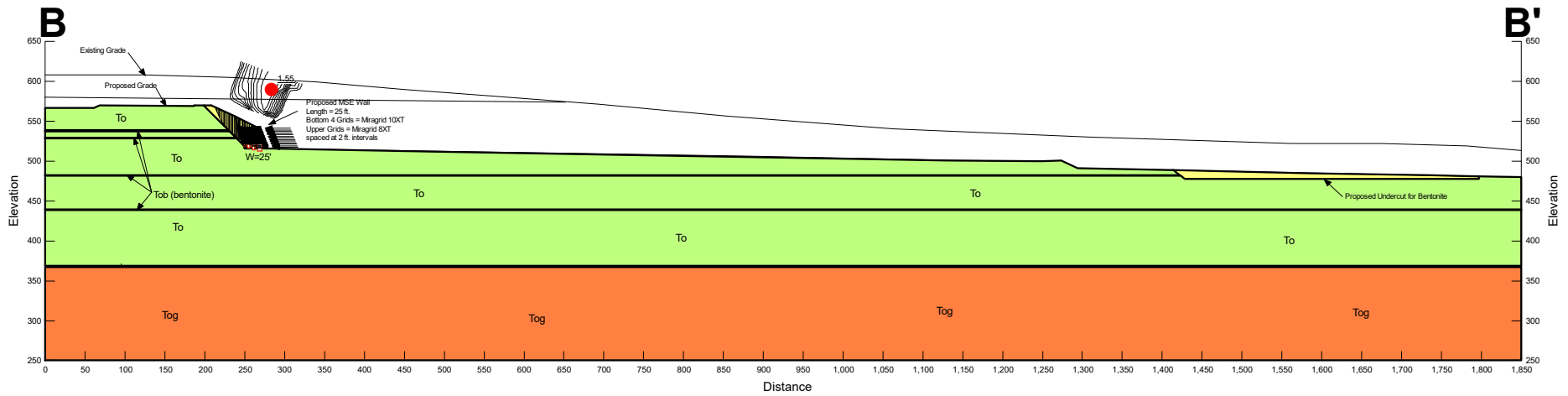

Project Name: Otay Ranch Village 8
 Project No. G1006-52-05
 Section B-B'
 File Name: B-B'_Case2a.gsz
 Date: 09/26/2022, Time: 09:51:31 AM

Material Properties:

Color	Name	Unit Weight (pcf)	Cohesion' (psf)	Phi' (°)
Yellow	Qcf	125	250	28
Light Green	To	130	350	34
Red	Tob (bentonite)	120	30	6
Orange	Tog	130	350	34

Proposed Grade
 Static Condition
 Block-mode Analysis Along Bentonite

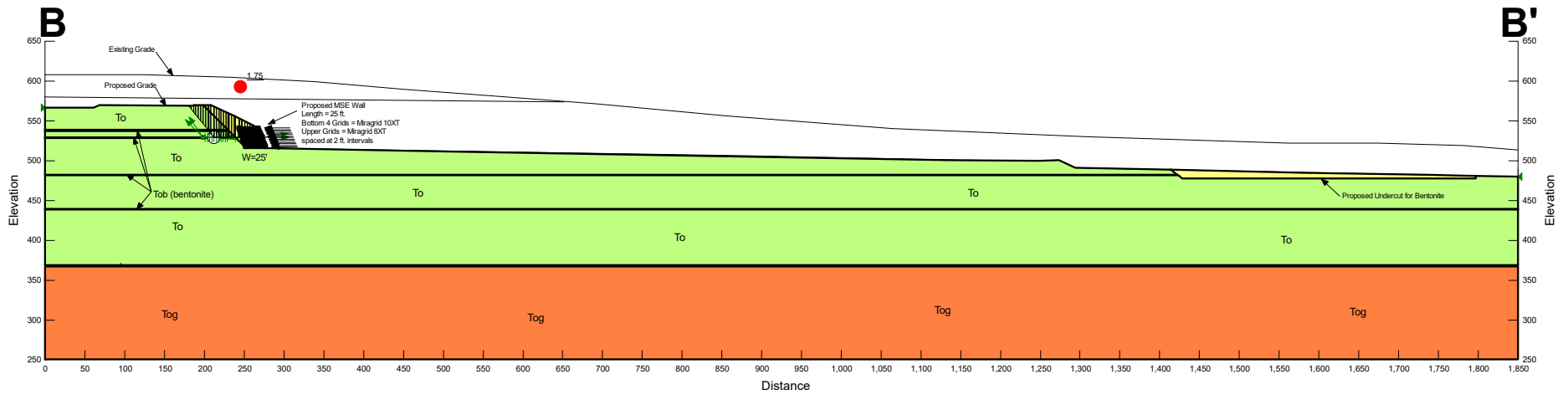

Project Name: Otay Ranch Village 8
 Project No. G1006-52-05
 Section B-B'
 File Name: B-B'_Case3a.gsz
 Date: 09/26/2022, Time: 09:52:24 AM

Material Properties:

Color	Name	Unit Weight (pcf)	Cohesion' (psf)	Phi' (°)
Yellow	Qcf	125	250	28
Light Green	To	130	350	34
Red	Tob (bentonite)	120	30	6
Orange	Tog	130	350	34

Proposed Grade
 Static Condition
 Block-mode Analysis Along Bentonite

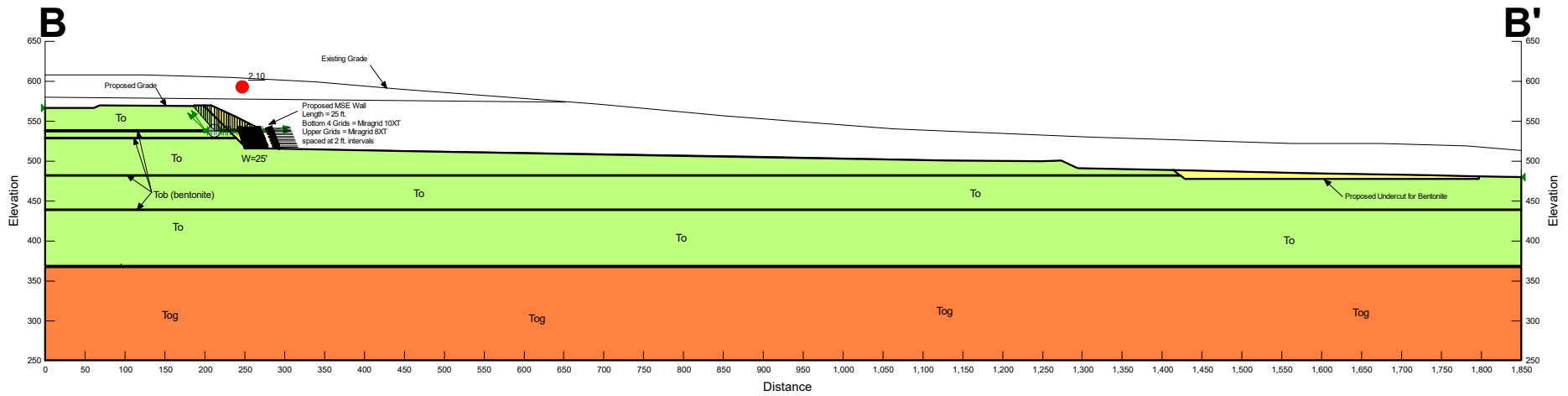

Project Name: Otay Ranch Village 8
 Project No. G1006-52-05
 Section B-B'
 File Name: B-B'_Case4a.gsz
 Date: 09/26/2022, Time: 09:56:40 AM

Material Properties:

Color	Name	Unit Weight (pcf)	Cohesion' (psf)	Phi' (°)
Yellow	Qcf	125	250	28
Light Green	To	130	350	34
Red	Tob (bentonite)	120	30	6
Orange	Tog	130	350	34

Proposed Grade
 Static Condition
 Rotational-mode Analysis

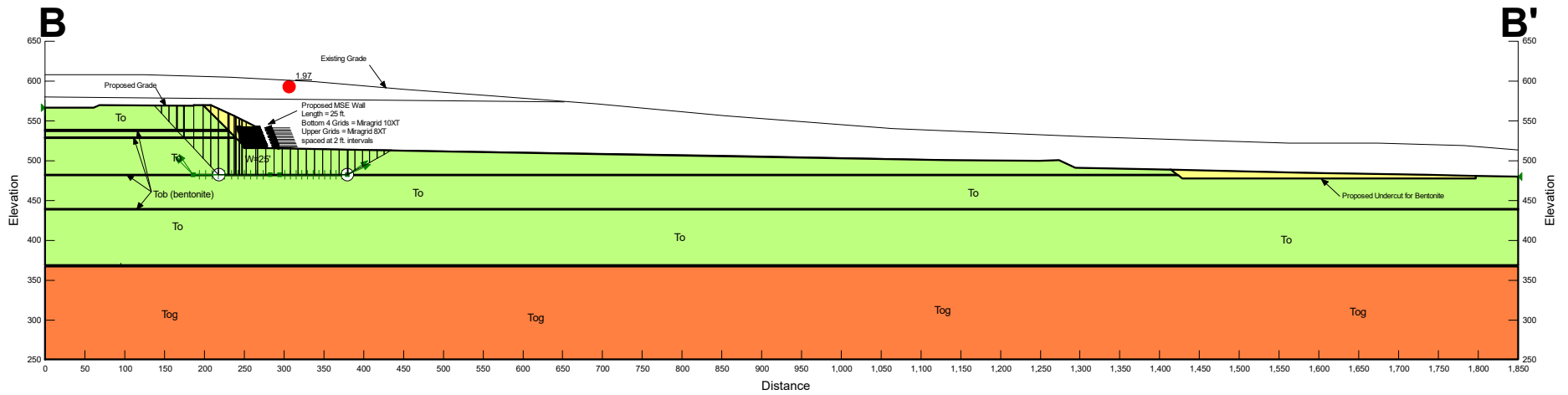

Project Name: Otay Ranch Village 8
 Project No. G1006-52-05
 Section C-C'
 File Name: C-C'_Case1.gsz
 Date: 09/23/2022, Time: 11:45:17 PM

Material Properties:

Color	Name	Unit Weight (pcf)	Cohesion' (psf)	Phi' (°)
Yellow	Qcf	125	250	28
Light Green	To	130	350	34
Red	Tob (bentonite)	120	30	6
Orange	Tog	130	350	34

Proposed Grade
 Static Condition
 Block-mode Analysis Along Bentonite

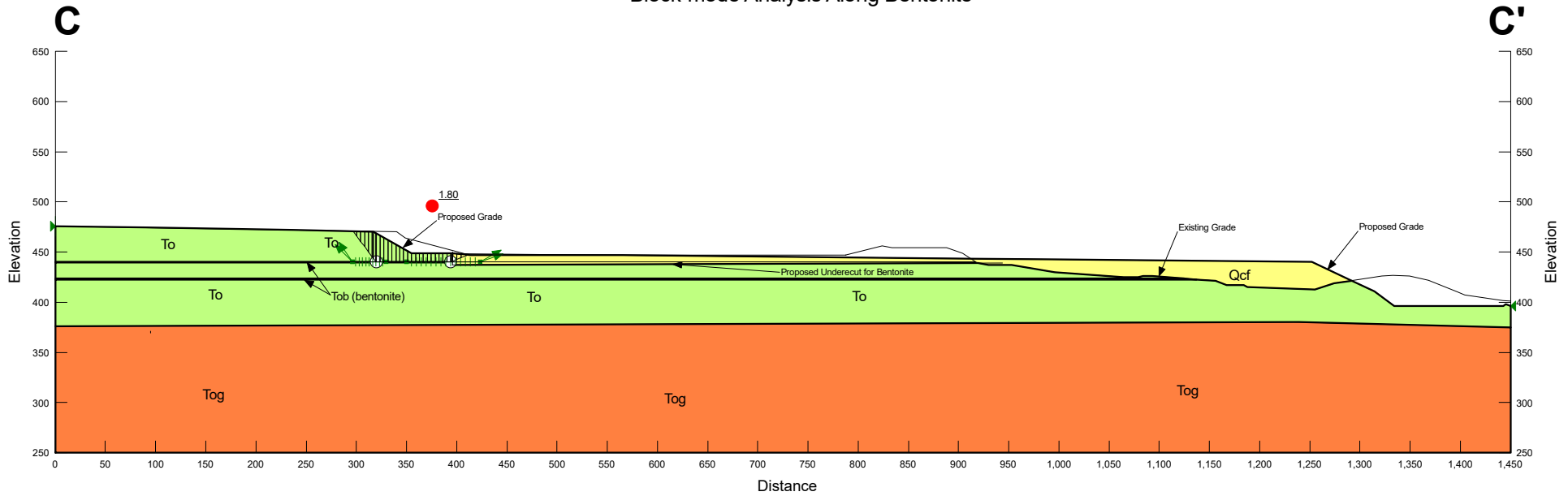

Project Name: Otay Ranch Village 8
 Project No. G1006-52-05
 Section C-C'
 File Name: C-C'_Case2.gsz
 Date: 09/26/2022, Time: 08:26:38 AM

Material Properties:

Color	Name	Unit Weight (pcf)	Cohesion' (psf)	Phi' (°)
Yellow	Qcf	125	250	28
Light Green	To	130	350	34
Red	Tob (bentonite)	120	30	6
Orange	Tog	130	350	34

Proposed Grade
 Static Condition
 Rotational-mode Analysis

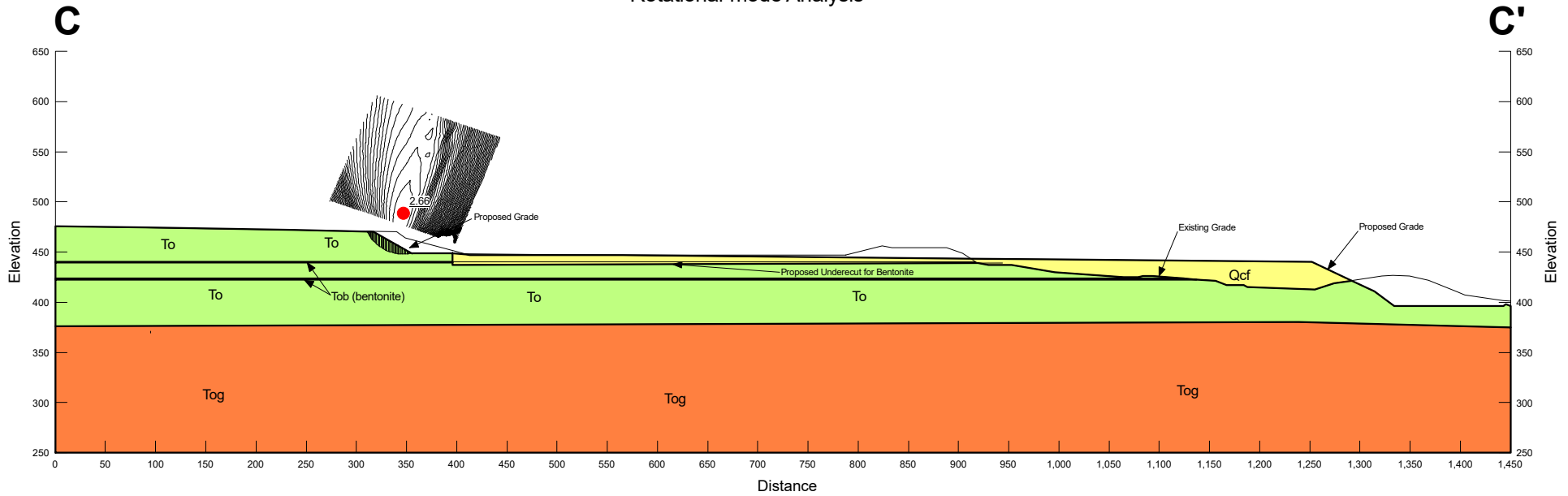

Project Name: Otay Ranch Village 8
 Project No. G1006-52-05
 Section C-C'
 File Name: C-C'_Case3.gsz
 Date: 09/26/2022, Time: 10:23:06 AM

Material Properties:

Color	Name	Unit Weight (pcf)	Cohesion' (psf)	Phi' (°)
Yellow	Qcf	125	250	28
Light Green	To	130	350	34
Red	Tob (bentonite)	120	30	6
Orange	Tog	130	350	34

Proposed Grade
 Static Condition
 Rotational-mode Analysis

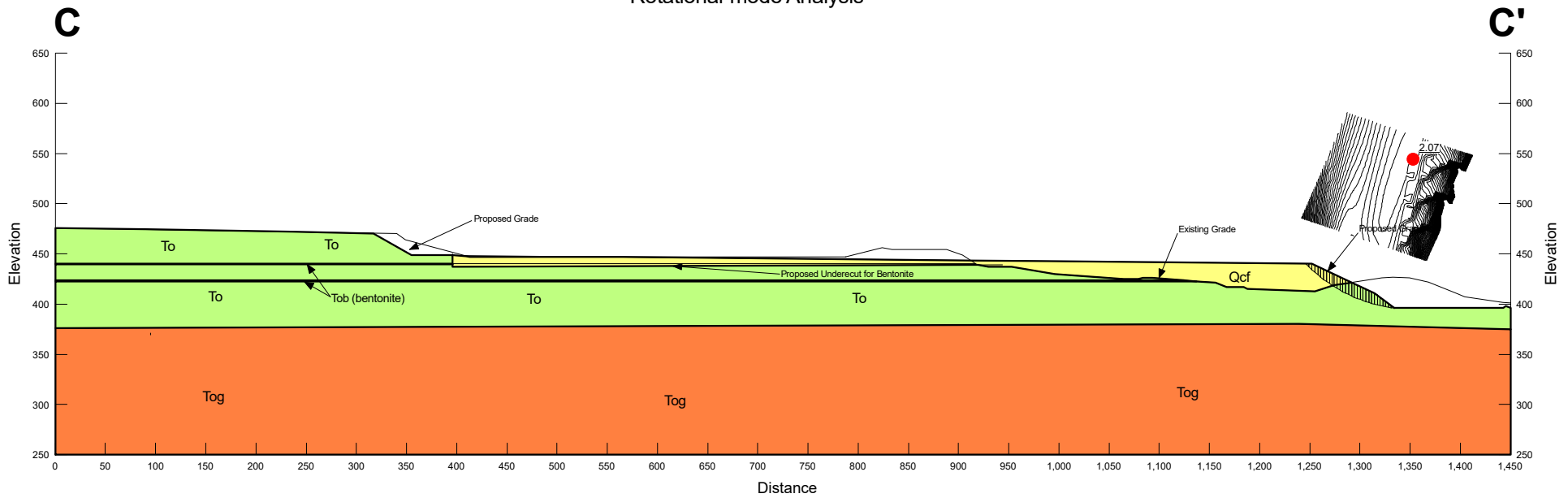

Project Name: Otay Ranch Village 8
 Project No. G1006-52-05
 Section D-D'
 File Name: D-D'_Case 1.gsz
 Date: 09/26/2022, Time: 10:26:10 AM

Material Properties:

Color	Name	Unit Weight (pcf)	Cohesion' (psf)	Phi' (°)
Yellow	Qcf	125	250	28
Light Green	To	130	350	34
Red	Tob (bentonite)	120	30	6
Orange	Tog	130	350	34

Proposed Grade
 Static Condition
 Block-mode Analysis Along Bentonite

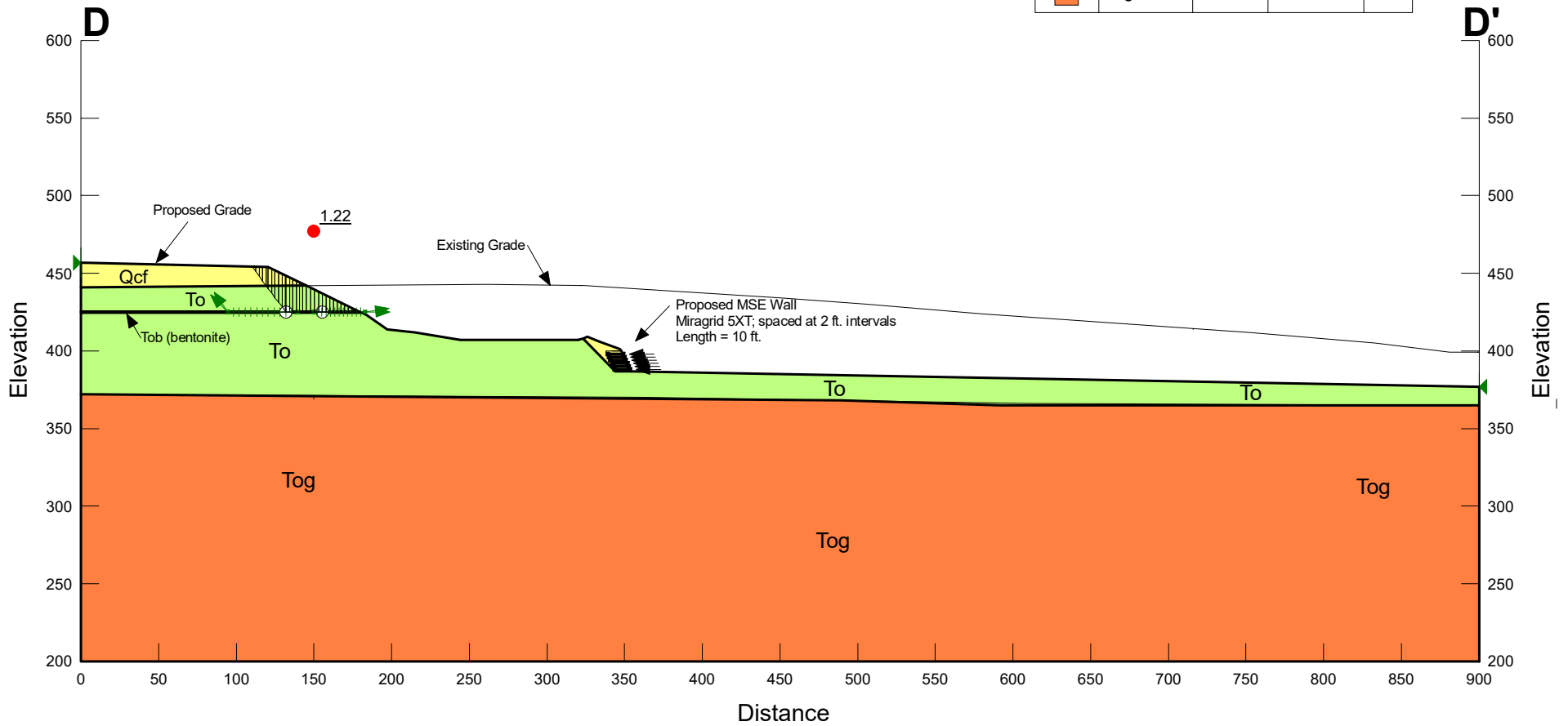

Project Name: Otay Ranch Village 8
 Project No. G1006-52-05
 Section D-D'
 File Name: D-D'_Case 2.gsz
 Date: 09/27/2022, Time: 02:48:35 PM

Material Properties:

Color	Name	Unit Weight (pcf)	Cohesion' (psf)	Phi' (°)
Yellow	Qcf	125	250	28
Light Green	To	130	350	34
Red	Tob (bentonite)	120	30	6
Orange	Tog	130	350	34

Proposed Grade
 Static Condition
 Block-mode Analysis Along Bentonite
 w/ 20 ft. Buttress

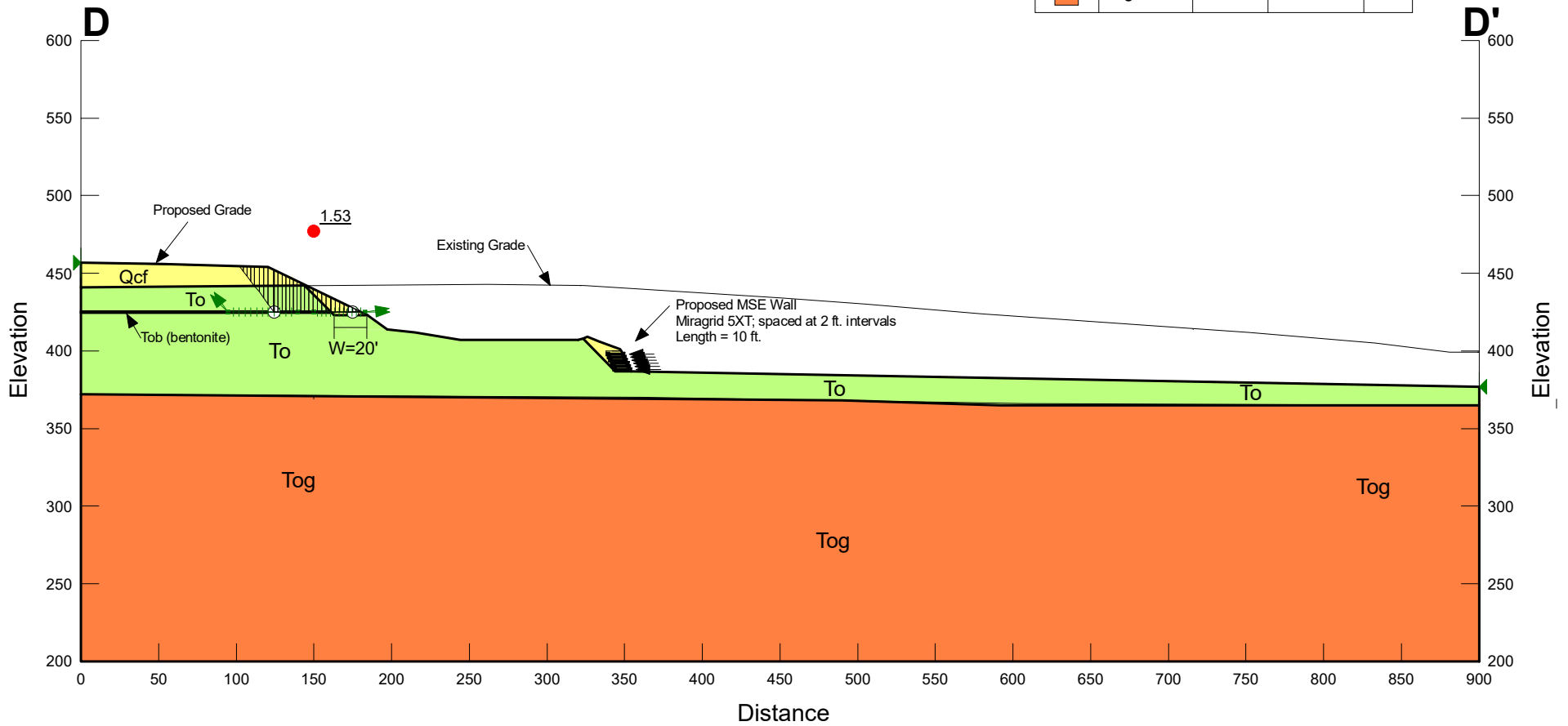

Project Name: Otay Ranch Village 8
 Project No. G1006-52-05
 Section D-D'
 File Name: D-D'_Case 3.gsz
 Date: 09/27/2022, Time: 02:53:15 PM

Material Properties:

Color	Name	Unit Weight (pcf)	Cohesion' (psf)	Phi' (°)
Yellow	Qcf	125	250	28
Light Green	To	130	350	34
Red	Tob (bentonite)	120	30	6
Orange	Tog	130	350	34

Proposed Grade
 Static Condition
 Block-mode Analysis Along Bentonite
 w/ 20 ft. Buttress

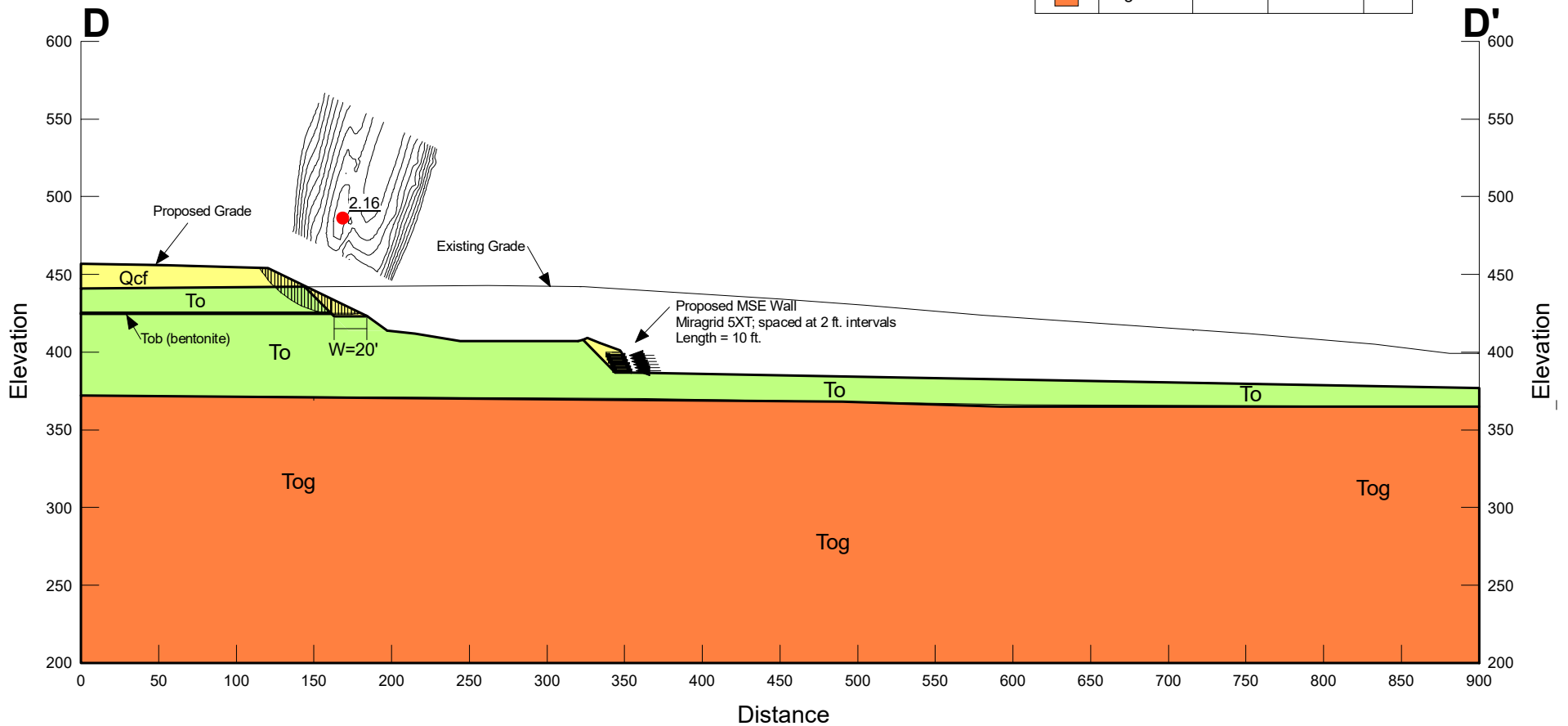

Project Name: Otay Ranch Village 8
 Project No. G1006-52-05
 Section D-D'
 File Name: D-D'_Case 4.gsz
 Date: 09/27/2022, Time: 02:55:41 PM

Material Properties:

Color	Name	Unit Weight (pcf)	Cohesion' (psf)	Phi' (°)
Yellow	Qcf	125	250	28
Light Green	To	130	350	34
Red	Tob (bentonite)	120	30	6
Orange	Tog	130	350	34

Proposed Grade
 Static Condition
 Block-mode Analysis Along Bentonite
 w/ 25 ft. Buttress

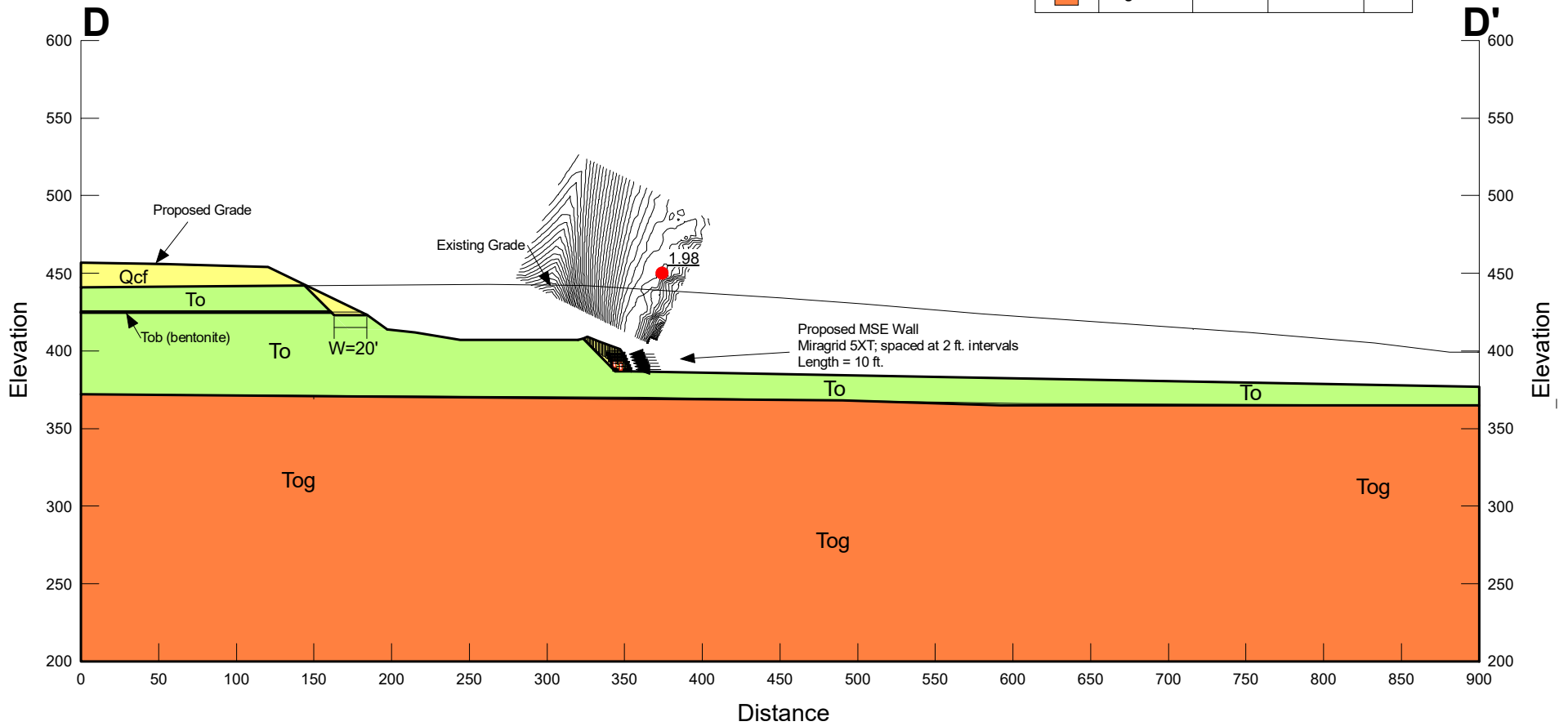

Project Name: Otay Ranch Village 8
 Project No. G1006-52-05
 Section E-E'
 File Name: E-E'_Case1.gsz
 Date: 09/26/2022, Time: 12:58:31 PM

Material Properties:

Color	Name	Unit Weight (pcf)	Cohesion' (psf)	Phi' (°)
Yellow	Qcf	125	250	28
Light Green	To	130	350	34
Red	Tob (bentonite)	120	30	6
Orange	Tog	130	350	34

Proposed Grade
 Static Condition
 Block-mode Analysis Along Bentonite

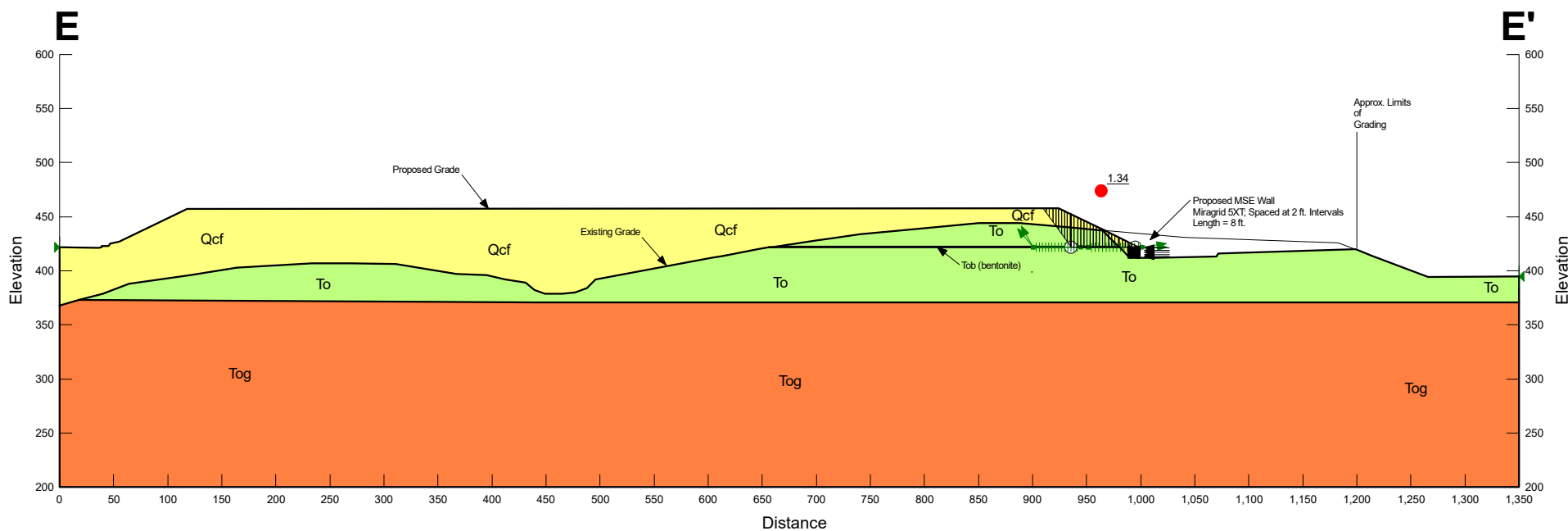

Project Name: Otay Ranch Village 8
 Project No. G1006-52-05
 Section E-E'
 File Name: E-E'_Case2.gsz
 Date: 09/26/2022, Time: 12:57:35 PM

Material Properties:

Color	Name	Unit Weight (pcf)	Cohesion' (psf)	Phi' (°)
Yellow	Qcf	125	250	28
Light Green	To	130	350	34
Red	Tob (bentonite)	120	30	6
Orange	Tog	130	350	34

Proposed Grade
 Static Condition
 Block-mode Analysis Along Bentonite
 w/ 30 ft. Wide Total Buttress (benched cut)

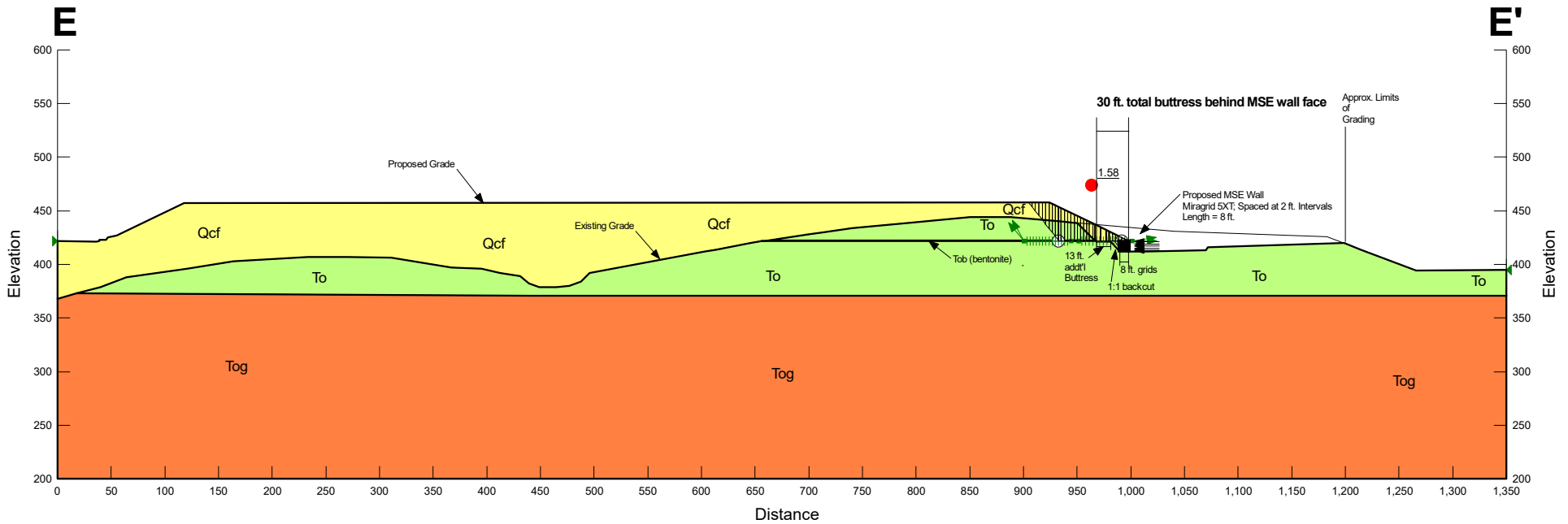

Project Name: Otay Ranch Village 8
 Project No. G1006-52-05
 Section E-E'
 File Name: E-E'_Case3.gsz
 Date: 09/27/2022, Time: 03:05:27 PM

Material Properties:

Color	Name	Unit Weight (pcf)	Cohesion' (psf)	Phi' (°)
Yellow	Qcf	125	250	28
Light Green	To	130	350	34
Red	Tob (bentonite)	120	30	6
Orange	Tog	130	350	34

Proposed Grade
 Static Condition
 Rotational-mode Analysis
 w/ 30 ft. Wide Total Buttress (benched cut)

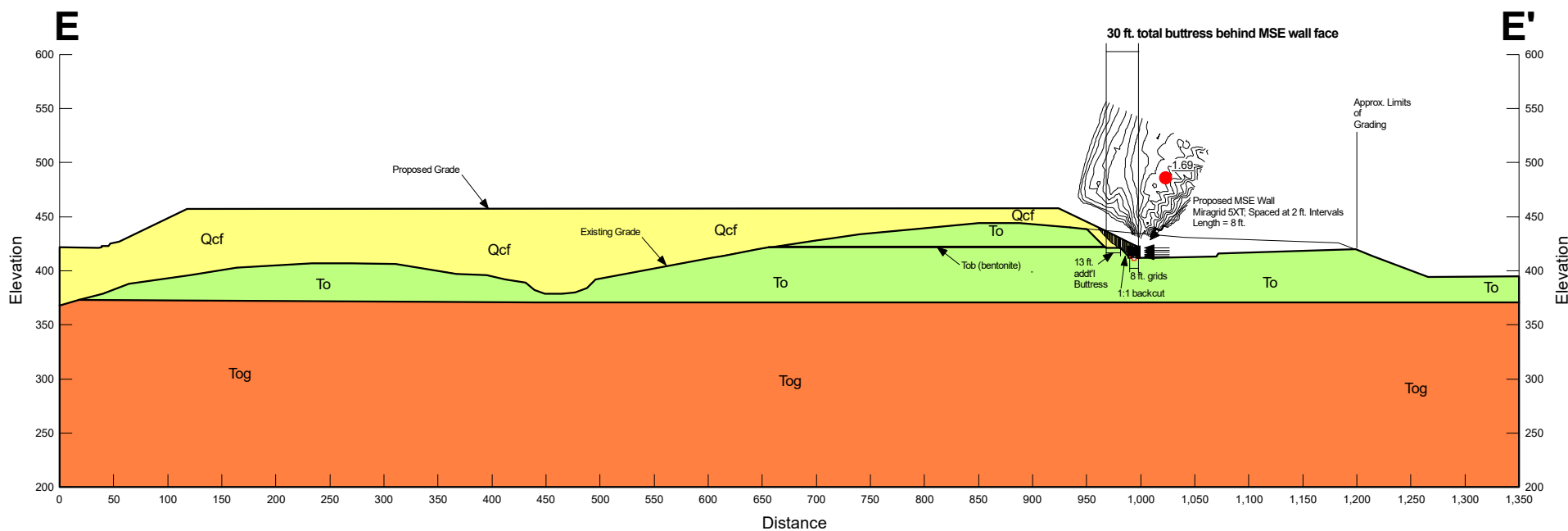

Project Name: Otay Ranch Village 8
 Project No. G1006-52-05
 Section F-F'
 File Name: F-F'_Case1.gsz
 Date: 09/26/2022, Time: 01:12:41 PM

Material Properties:

Color	Name	Unit Weight (pcf)	Cohesion' (psf)	Phi' (°)
Yellow	Qcf	125	250	28
Light Green	To	130	350	34
Red	Tob (bentonite)	120	30	6
Orange	Tog	130	350	34

Proposed Grade
 Static Condition
 Block-mode Analysis Along Bentonite

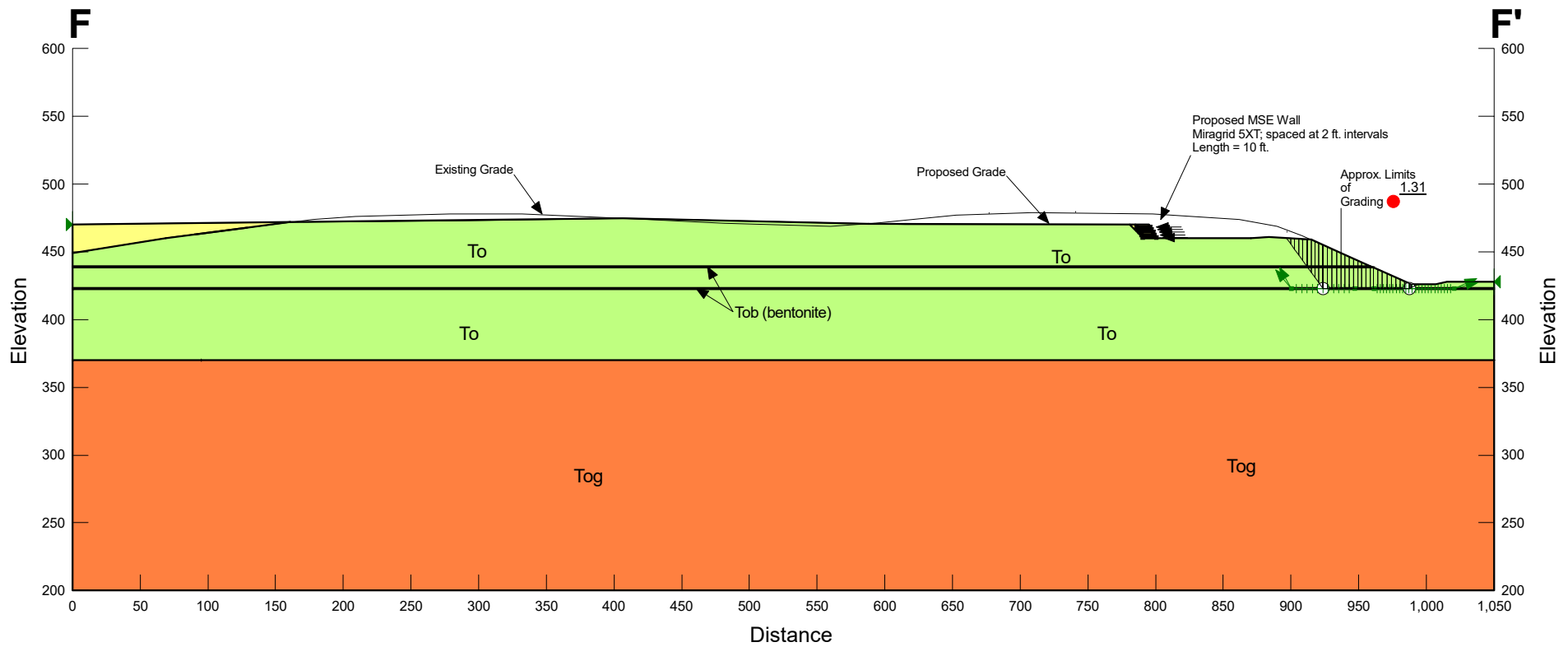

Project Name: Otay Ranch Village 8
 Project No. G1006-52-05
 Section F-F'
 File Name: F-F'_Case2.gsz
 Date: 09/27/2022, Time: 11:11:28 PM

Material Properties:

Color	Name	Unit Weight (pcf)	Cohesion (psf)	Phi (°)
Yellow	Qcf	125	250	28
Light Green	To	130	350	34
Red	Tob (bentonite)	120	30	6
Orange	Tog	130	350	34

Proposed Grade
 Static Condition
 Block-mode Analysis Along Bentonite

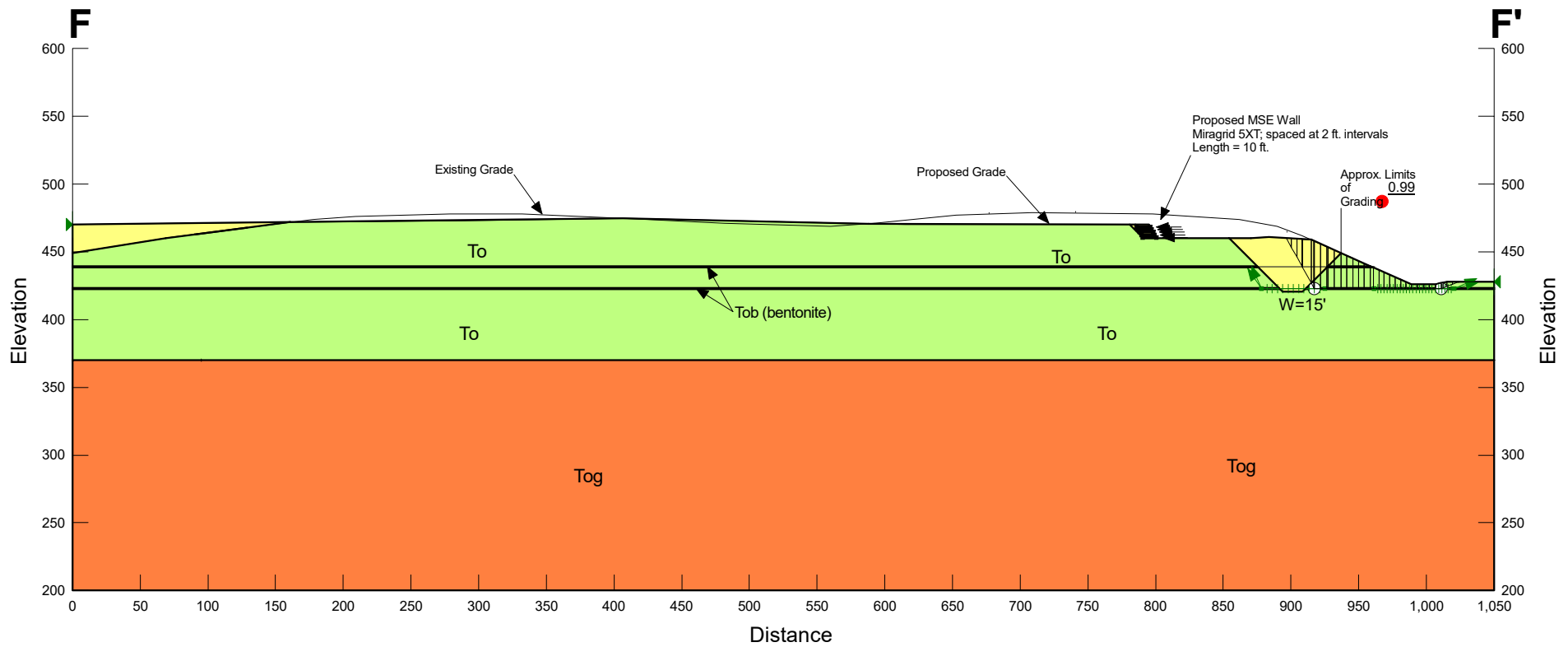

Project Name: Otay Ranch Village 8
 Project No. G1006-52-05
 Section F-F'
 File Name: F-F'_Case3.gsz
 Date: 09/27/2022, Time: 11:18:28 PM

Proposed Grade
 Static Condition
 Block-mode Analysis Along Bentonite
 Setback Where FOS=1.5

Material Properties:

Color	Name	Unit Weight (pcf)	Cohesion (psf)	Phi' (°)
Yellow	Qcf	125	250	28
Light Green	To	130	350	34
Red	Tob (bentonite)	120	30	6
Orange	Tog	130	350	34

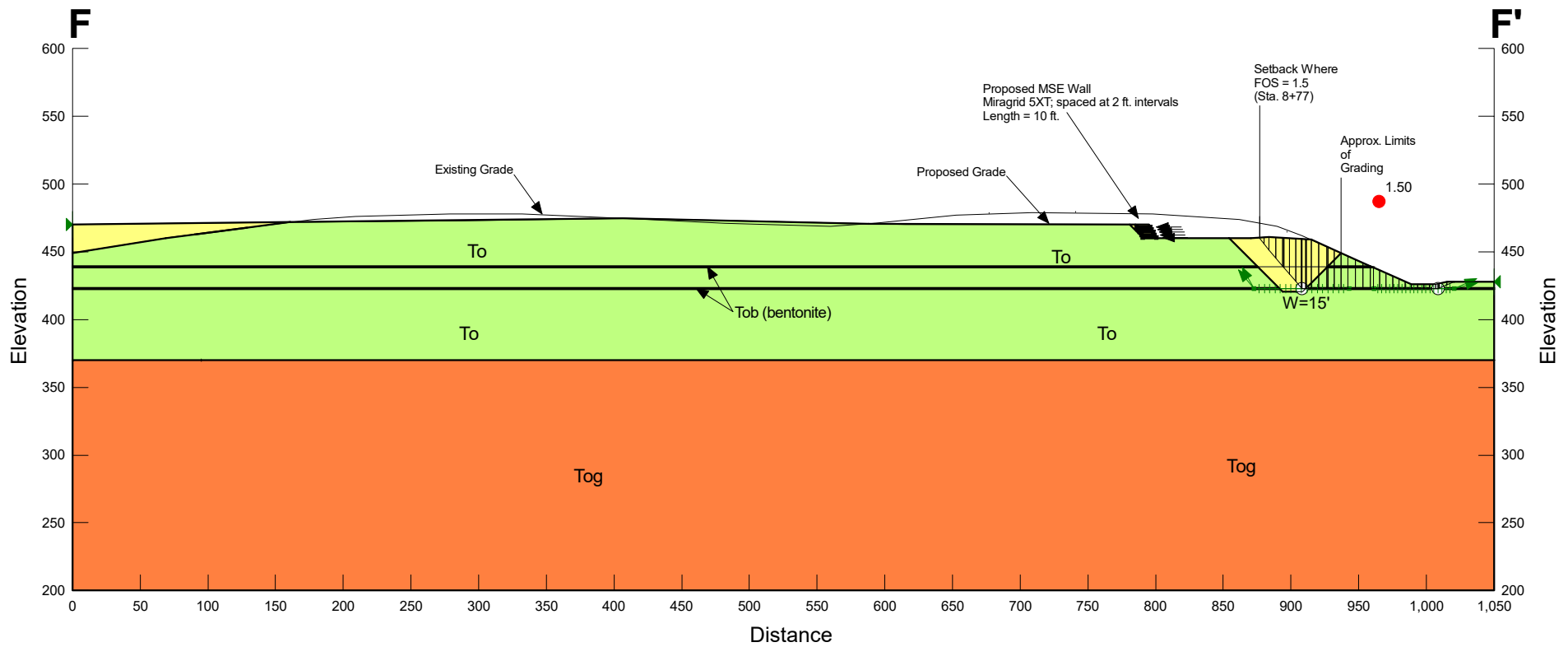

Project Name: Otay Ranch Village 8
 Project No. G1006-52-05
 Section F-F'
 File Name: F-F'_Case4.gsz
 Date: 09/27/2022, Time: 03:16:26 PM

Material Properties:

Color	Name	Unit Weight (pcf)	Cohesion' (psf)	Phi' (°)
Yellow	Qcf	125	250	28
Light Green	To	130	350	34
Red	Tob (bentonite)	120	30	6
Orange	Tog	130	350	34

Proposed Grade
 Static Condition
 Block-mode Analysis Along Bentonite
 Buttress Outside Limits of Grading; width = 15 ft.

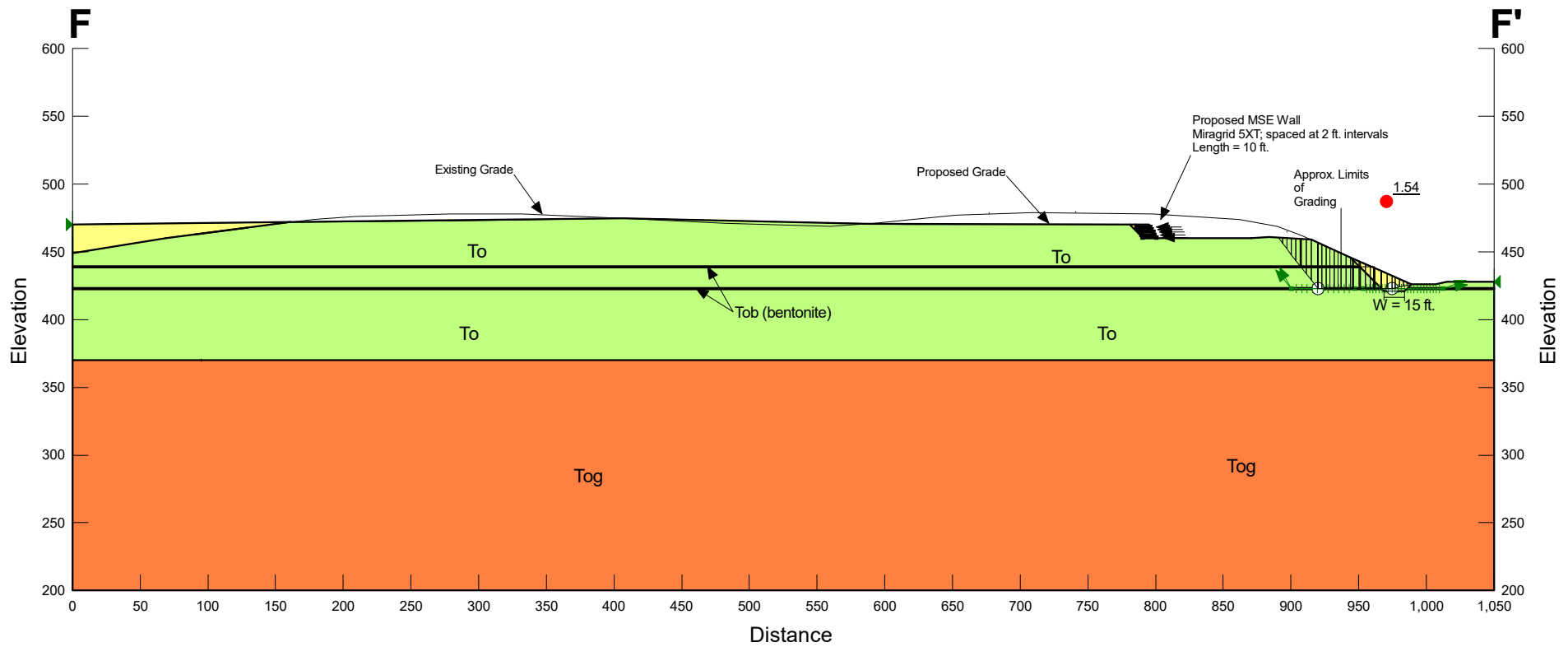

Project Name: Otay Ranch Village 8
 Project No. G1006-52-05
 Section G-G'
 File Name: G-G'_Case1.gsz
 Date: 09/26/2022, Time: 01:23:37 PM

Material Properties:

Color	Name	Unit Weight (pcf)	Cohesion' (psf)	Phi' (°)
	To	130	350	34
	Tob (bentonite)	120	30	6

Proposed Grade
 Static Condition
 Block-mode Analysis Along Bentonite Layer

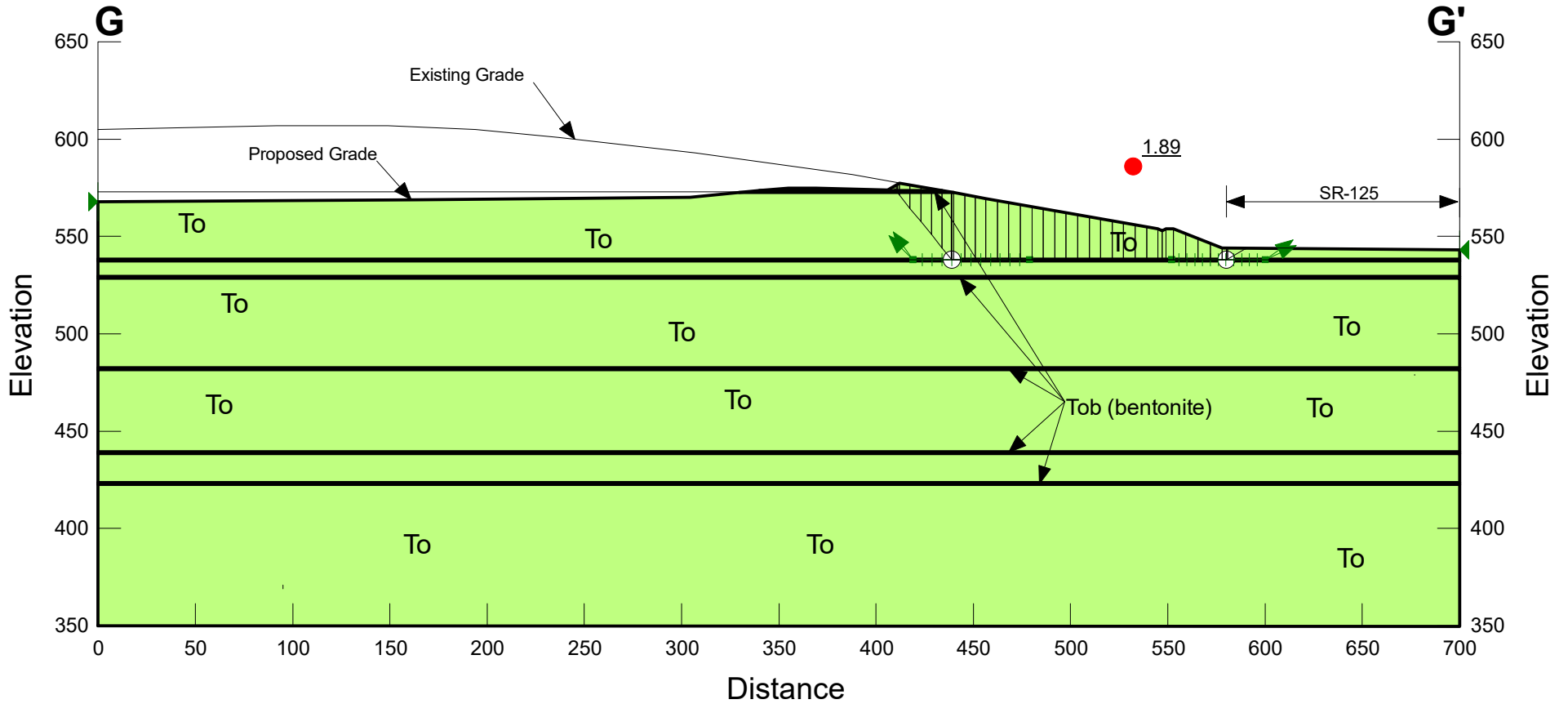

Project Name: Otay Ranch Village 8
 Project No. G1006-52-05
 Section G-G'
 File Name: G-G'_Case2.gsz
 Date: 09/26/2022, Time: 01:32:18 PM

Proposed Grade
 Static Condition
 Rotational-mode Analysis

Material Properties:

Color	Name	Unit Weight (pcf)	Cohesion' (psf)	Phi' (°)
	To	130	350	34
	Tob (bentonite)	120	30	6

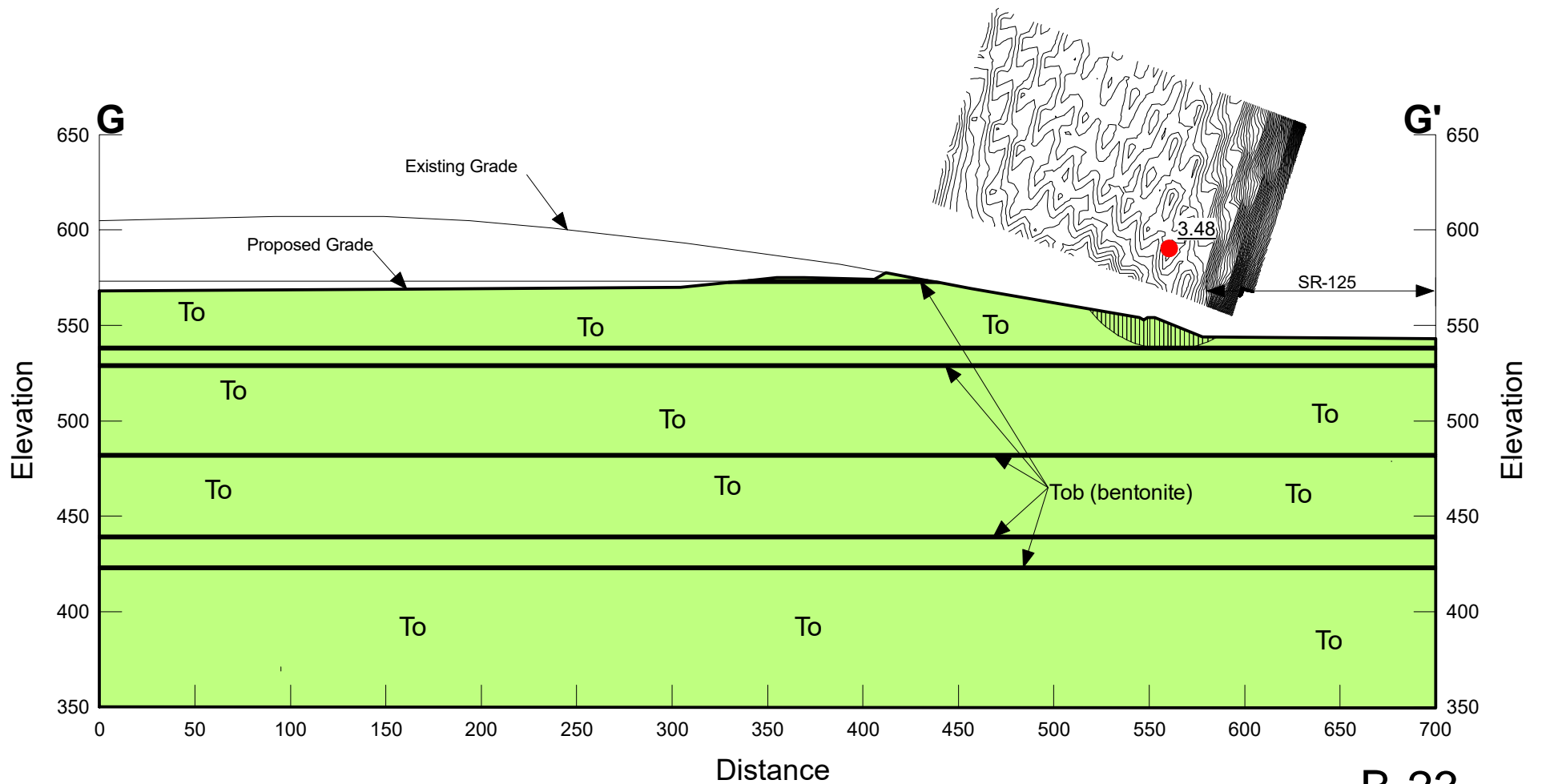

B-23

Project Name: Otay Ranch Village 8
 Project No. G1006-52-05
 File Name: H-H'_Case1.gsz
 Date: 09/26/2022, Time: 01:56:06 PM

Material Properties:

Color	Name	Unit Weight (pcf)	Cohesion' (psf)	Phi' (°)
Yellow	Qcf	125	250	28
Light Green	To	130	350	34
Red	Tob (bentonite)	120	30	6

Proposed Grade
 Rotational Mode Analysis - MSE Wall

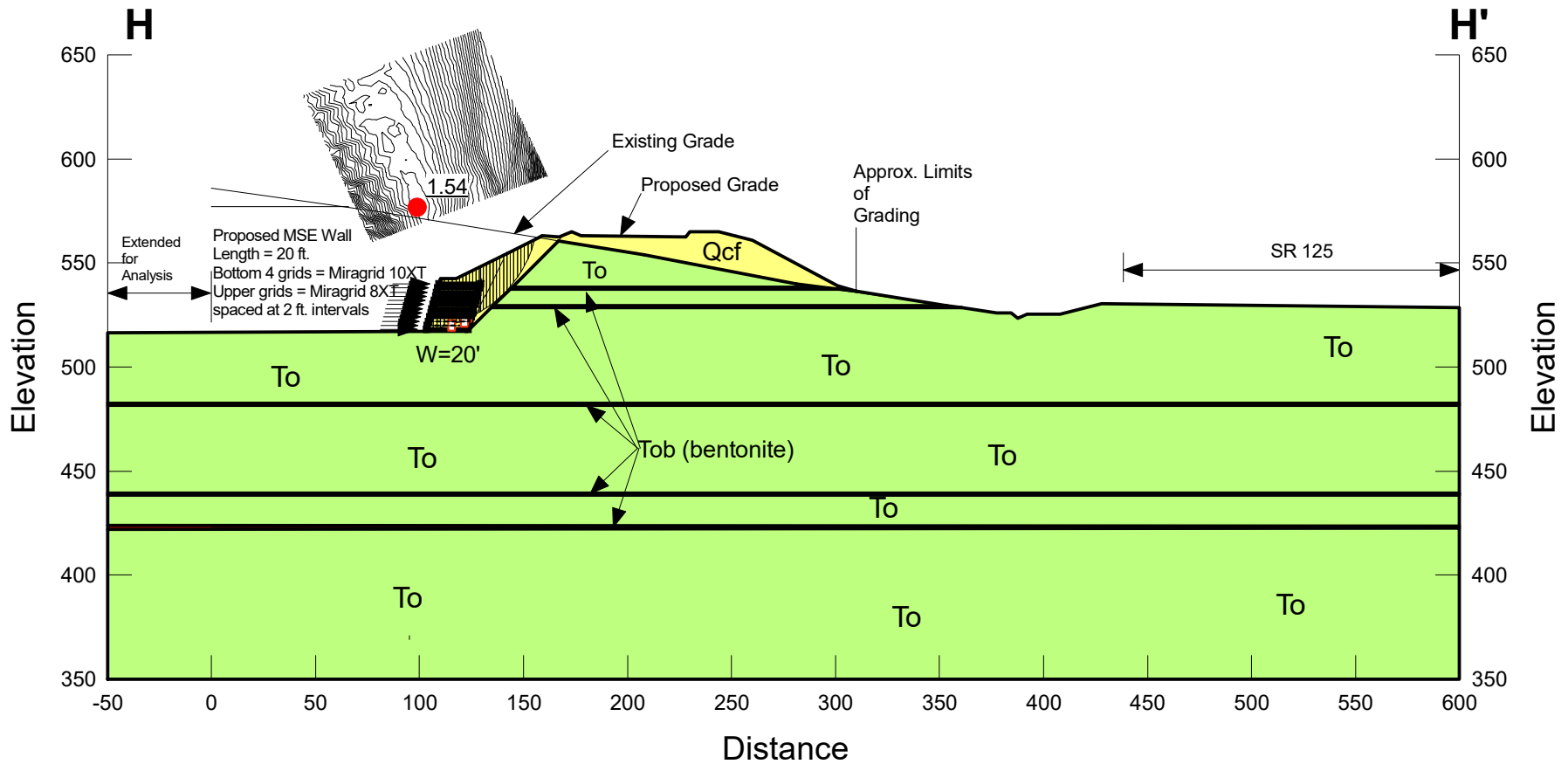

Project Name: Otay Ranch Village 8
 Project No. G1006-52-05
 Section H-H'
 File Name: H-H'_Case2.gsz
 Date: 09/26/2022, Time: 01:57:49 PM

Material Properties:

Color	Name	Unit Weight (pcf)	Cohesion' (psf)	Phi' (°)
Yellow	Qcf	125	250	28
Light Green	To	130	350	34
Red	Tob (bentonite)	120	30	6

Proposed Grade
 Block-mode Analysis Along Bentonite - Below MSE Wall

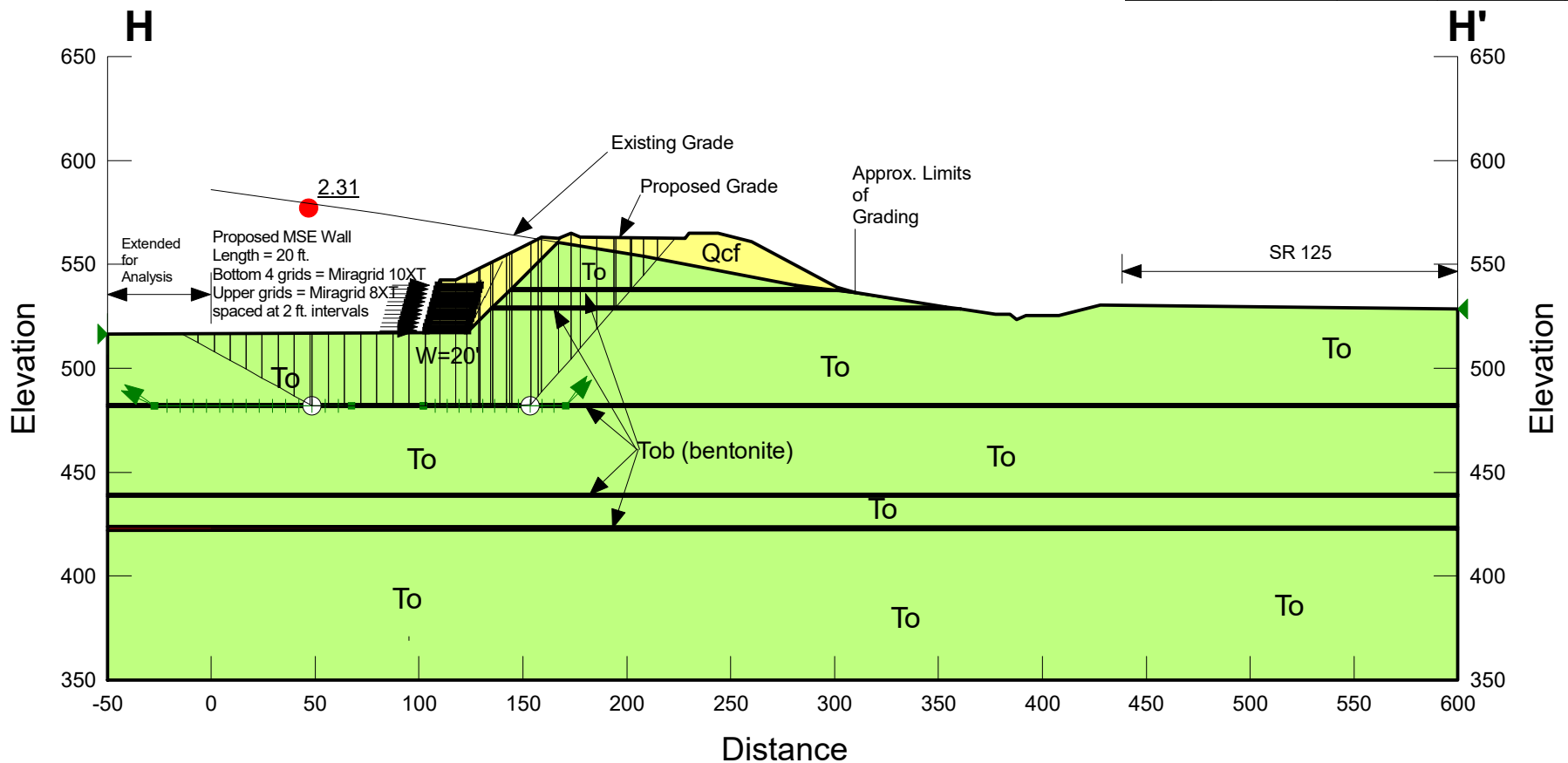

Project Name: Otay Ranch Village 8
 Project No. G1006-52-05
 Section H-H'
 File Name: H-H'_Case3.gsz
 Date: 09/26/2022, Time: 02:06:07 PM

Material Properties:

Color	Name	Unit Weight (pcf)	Cohesion' (psf)	Phi' (°)
Yellow	Qcf	125	250	28
Light Green	To	130	350	34
Red	Tob (bentonite)	120	30	6

Proposed Grade
 Block-mode Analysis Along Bentonite - Behind MSE Wall

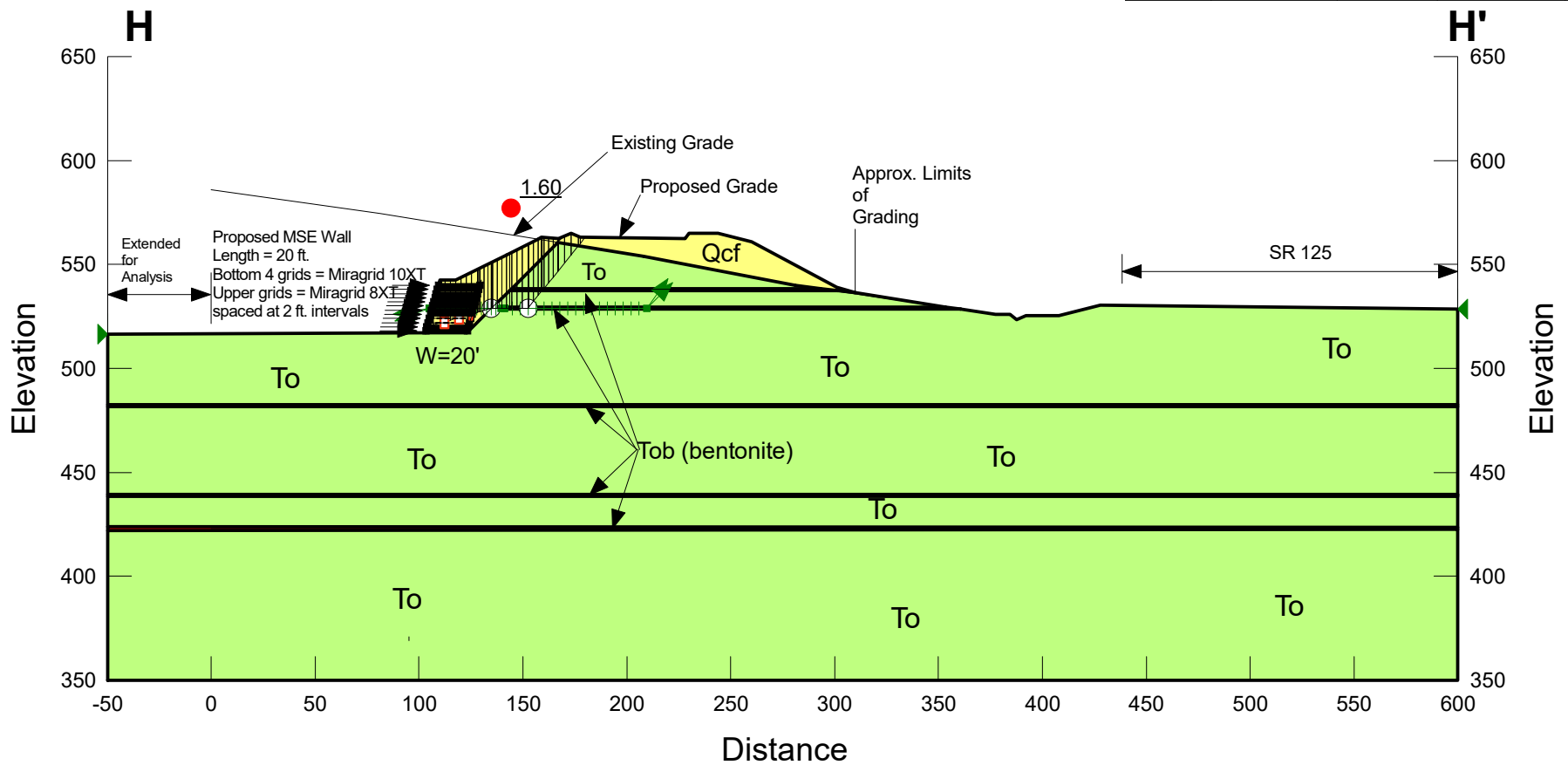

Project Name: Otay Ranch Village 8
 Project No. G1006-52-05
 Section H-H'
 File Name: H-H'_Case4.gsz
 Date: 09/26/2022, Time: 02:09:09 PM

Material Properties:

Color	Name	Unit Weight (pcf)	Cohesion' (psf)	Phi' (°)
Yellow	Qcf	125	250	28
Light Green	To	130	350	34
Red	Tob (bentonite)	120	30	6

Proposed Grade
 Block-mode Analysis Along Bentonite - Behind MSE Wall

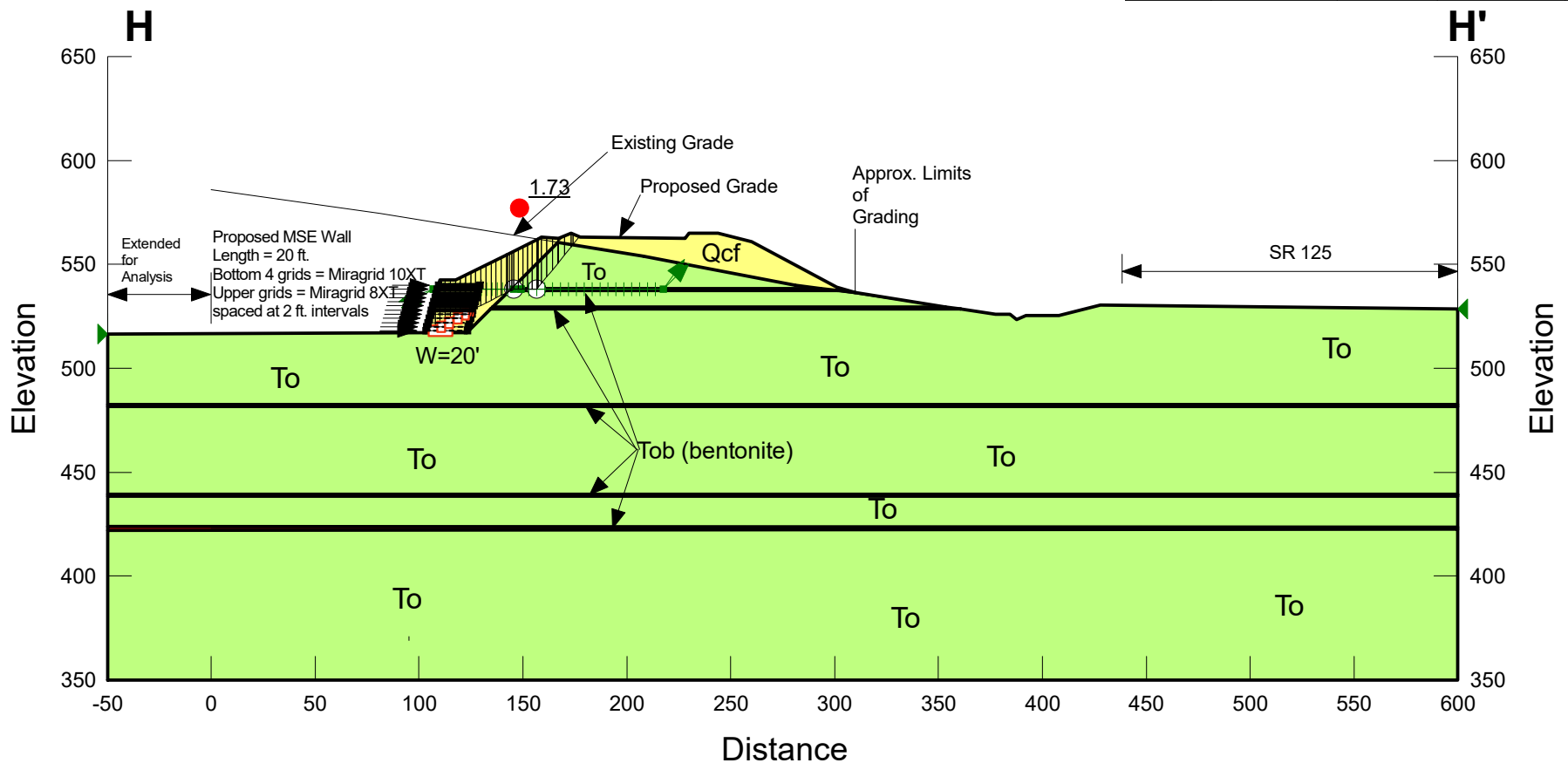

Project Name: Otay Ranch Village 8
 Project No. G1006-11-05
 Section H-H'
 File Name: H-H'_Case5.gsz
 Date: 09/26/2022, Time: 02:14:22 PM

Material Properties:

Color	Name	Unit Weight (pcf)	Cohesion' (psf)	Phi' (°)
Yellow	Qcf	125	250	28
Light Green	To	130	350	34
Red	Tob (bentonite)	120	30	6

Proposed Grade
 Block-mode Analysis Along Bentonite

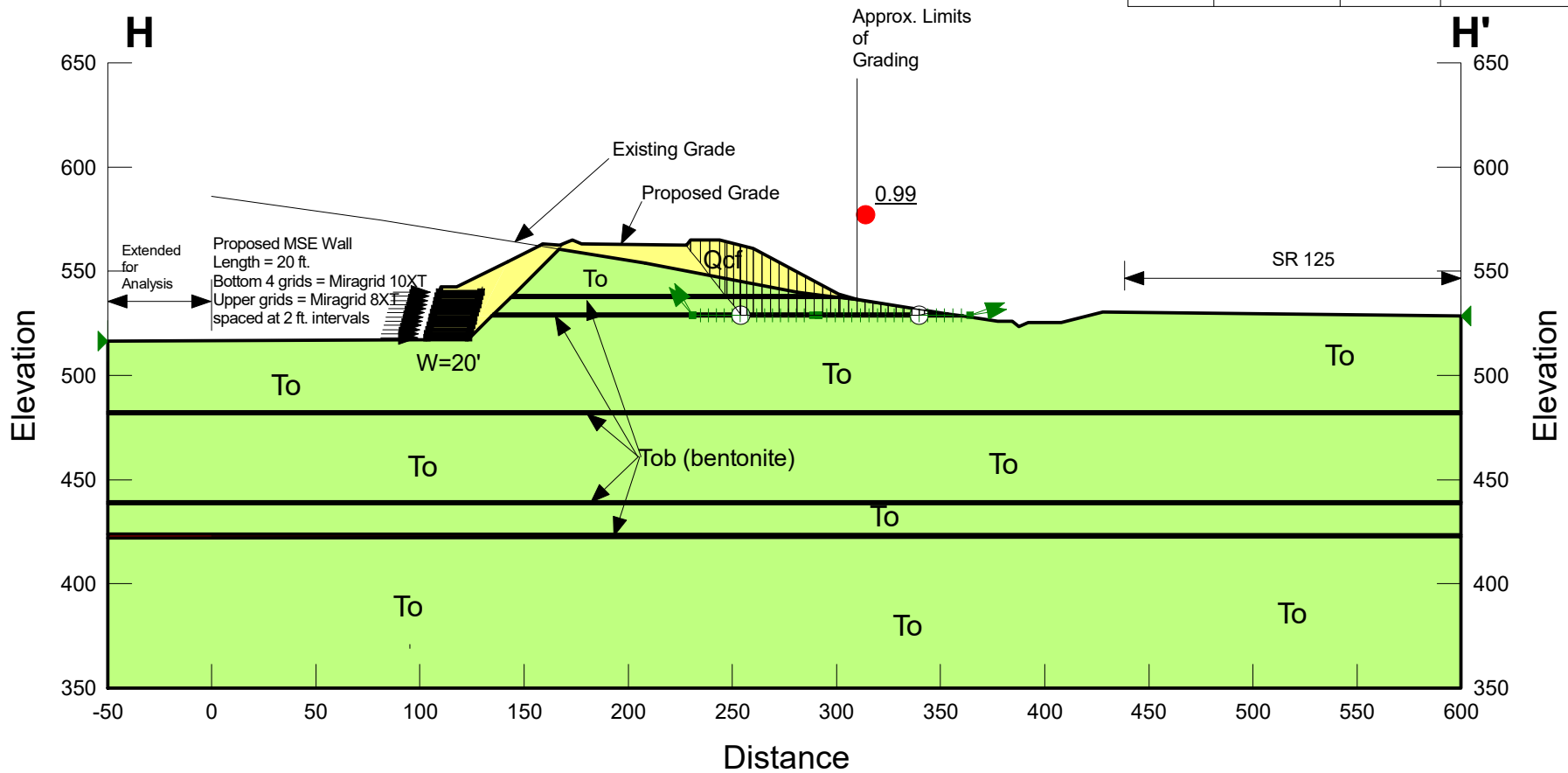

Project Name: Otay Ranch Village 8
 Project No. G1006-52-05
 Section H-H'
 File Name: H-H'_Case6.gsz
 Date: 09/27/2022, Time: 10:12:55 PM

Material Properties:

Color	Name	Unit Weight (pcf)	Cohesion' (psf)	Phi' (°)
Yellow	Qcf	125	250	28
Light Green	To	130	350	34
Red	Tob (bentonite)	120	30	6

Proposed Grade
 Block-mode Analysis Along Bentonite

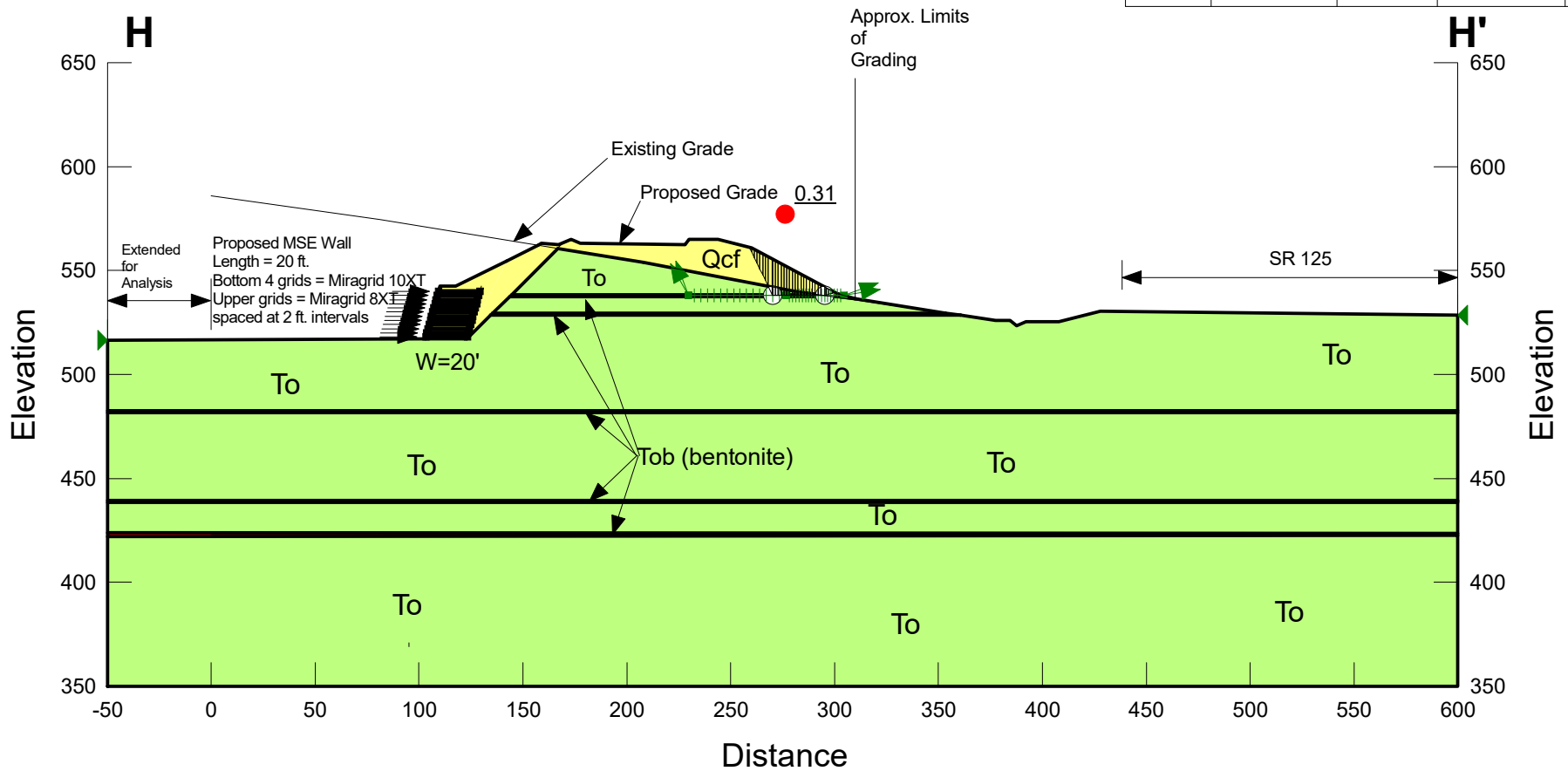

Project Name: Otay Ranch Village 8
 Project No. G1006-11-05
 Section H-H'
 File Name: H-H'_Case7.gsz
 Date: 09/27/2022, Time: 10:36:56 PM

Material Properties:

Color	Name	Unit Weight (pcf)	Cohesion' (psf)	Phi' (°)
Yellow	Qcf	125	250	28
Light Green	To	130	350	34
Red	Tob (bentonite)	120	30	6

Proposed Grade
 Block-mode Analysis Along Bentonite

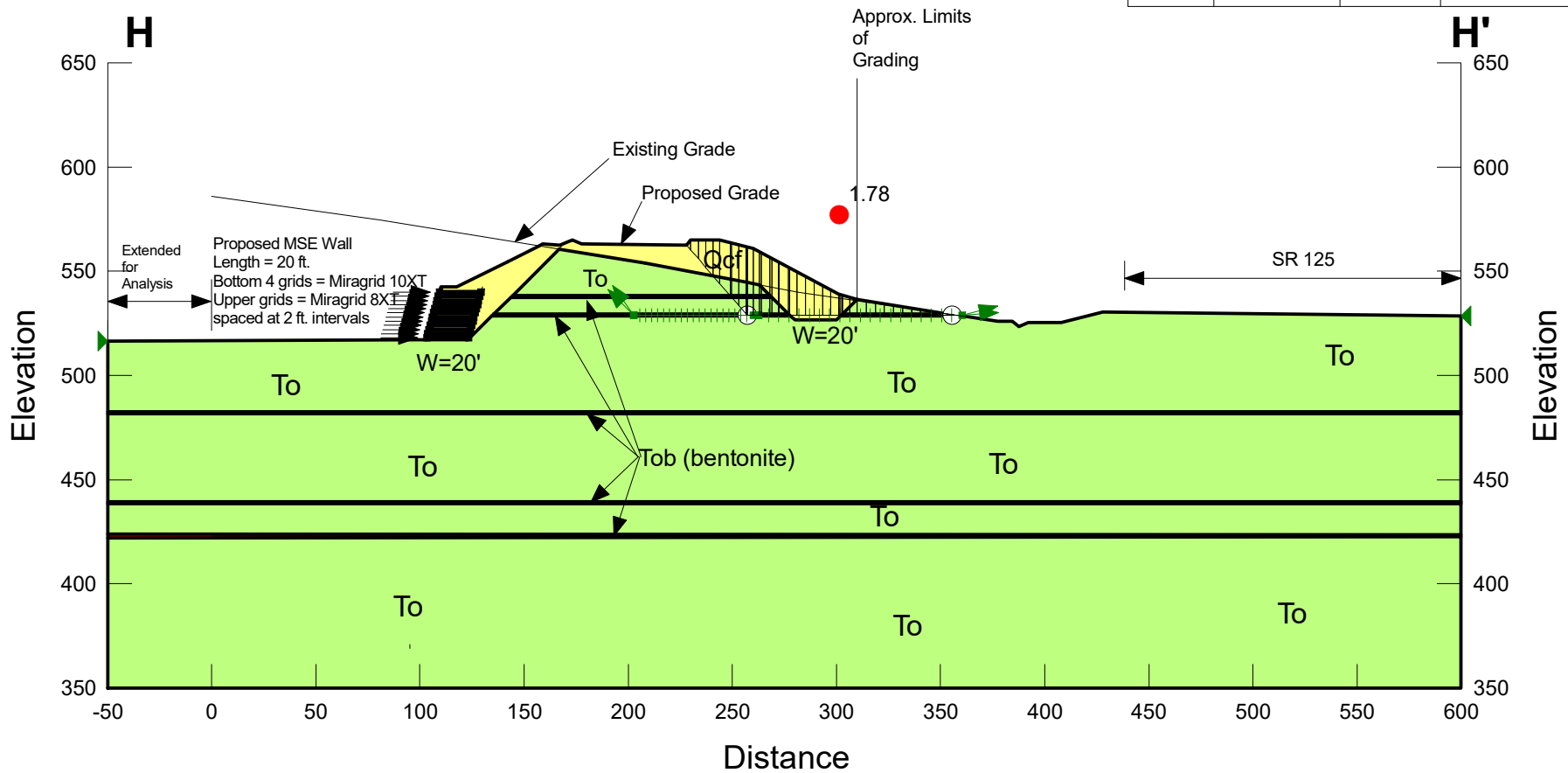

Project Name: Otay Ranch Village 8
 Project No. G1006-11-05
 Section H-H'
 File Name: H-H'_Case8.gsz
 Date: 09/27/2022, Time: 10:33:05 PM

Material Properties:

Color	Name	Unit Weight (pcf)	Cohesion' (psf)	Phi' (°)
Yellow	Qcf	125	250	28
Light Green	To	130	350	34
Red	Tob (bentonite)	120	30	6

Proposed Grade
 Block-mode Analysis Along Bentonite

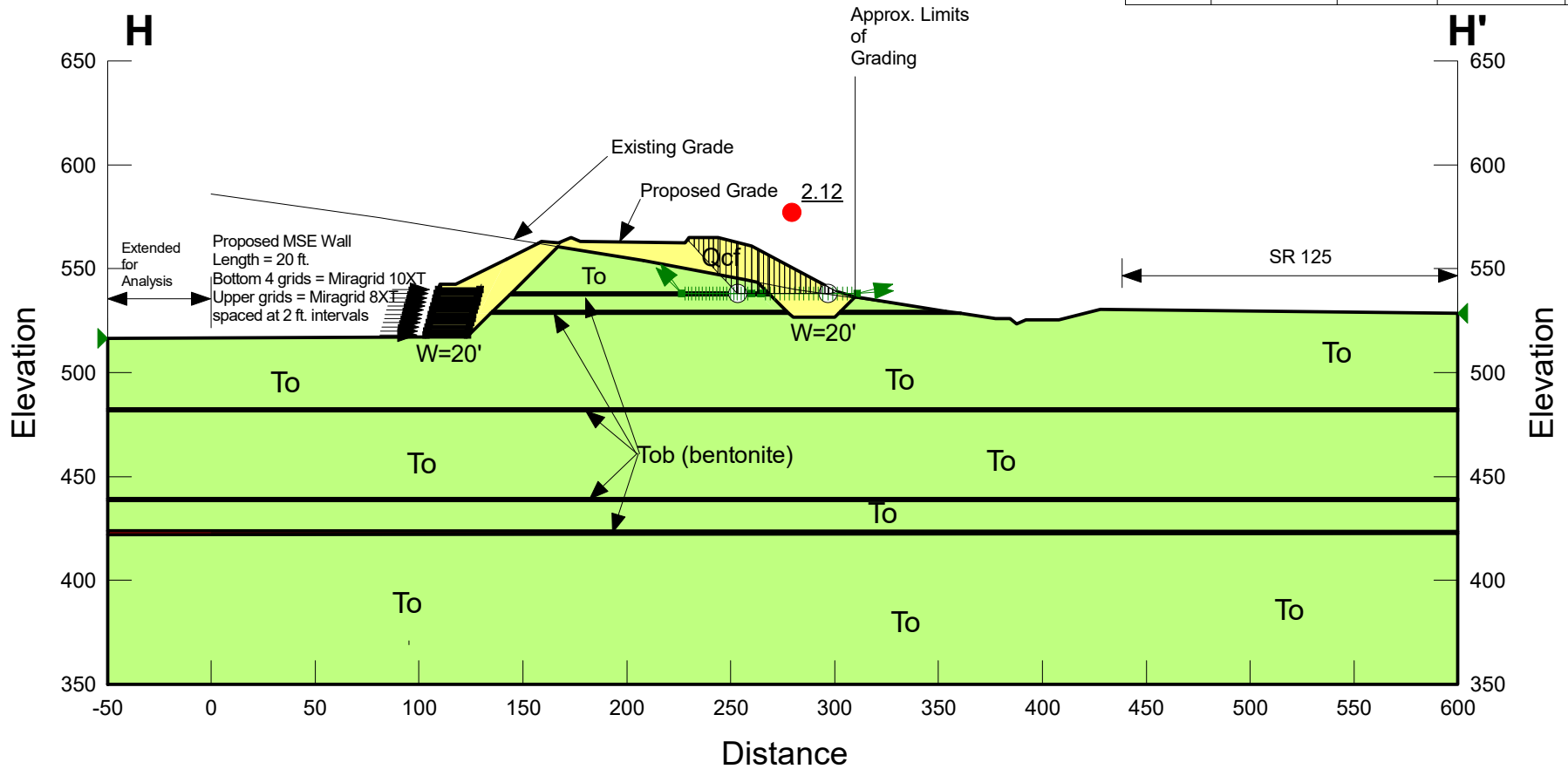

Project Name: Otay Ranch Village 8
 Project No. G1006-52-05
 Section H-H'
 File Name: H-H'_Case9.gsz
 Date: 09/26/2022, Time: 02:53:51 PM

Proposed Grade
 Rotational-mode Analysis
 w/ 20 ft. Wide Buttress

Material Properties:

Color	Name	Unit Weight (pcf)	Cohesion' (psf)	Phi' (°)
Yellow	Qcf	125	250	28
Light Green	To	130	350	34
Red	Tob (bentonite)	120	30	6

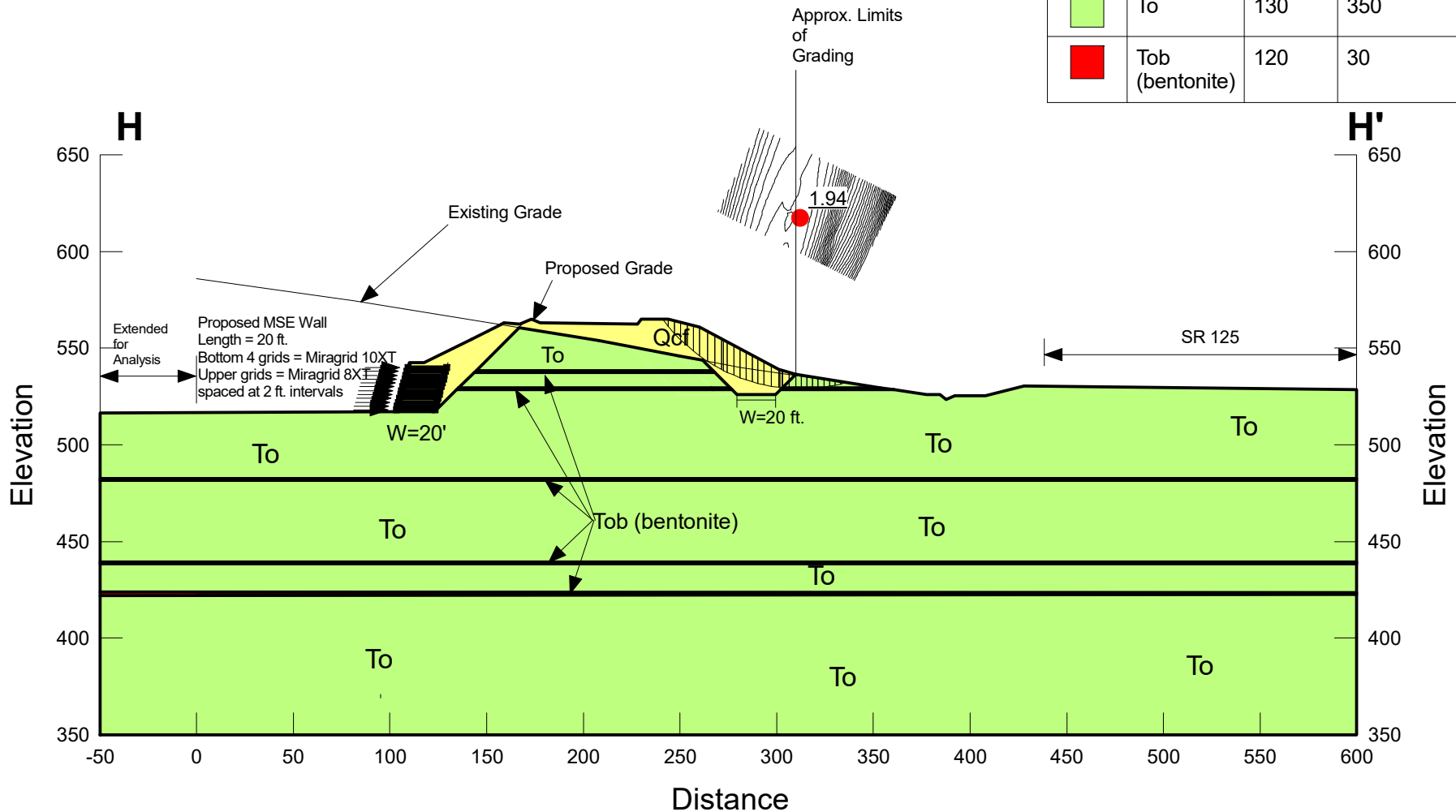

Project Name: Otay Ranch Village 8
 Project No. G1006-52-05

File Name: Fill Slope H=50.gsz
 Date: 09/28/2022, Time: 09:44:14 PM

Material Properties:

Color	Name	Unit Weight (pcf)	Cohesion' (psf)	Phi' (°)
	Qcf	125	250	28

50 ft. High Fill Slope

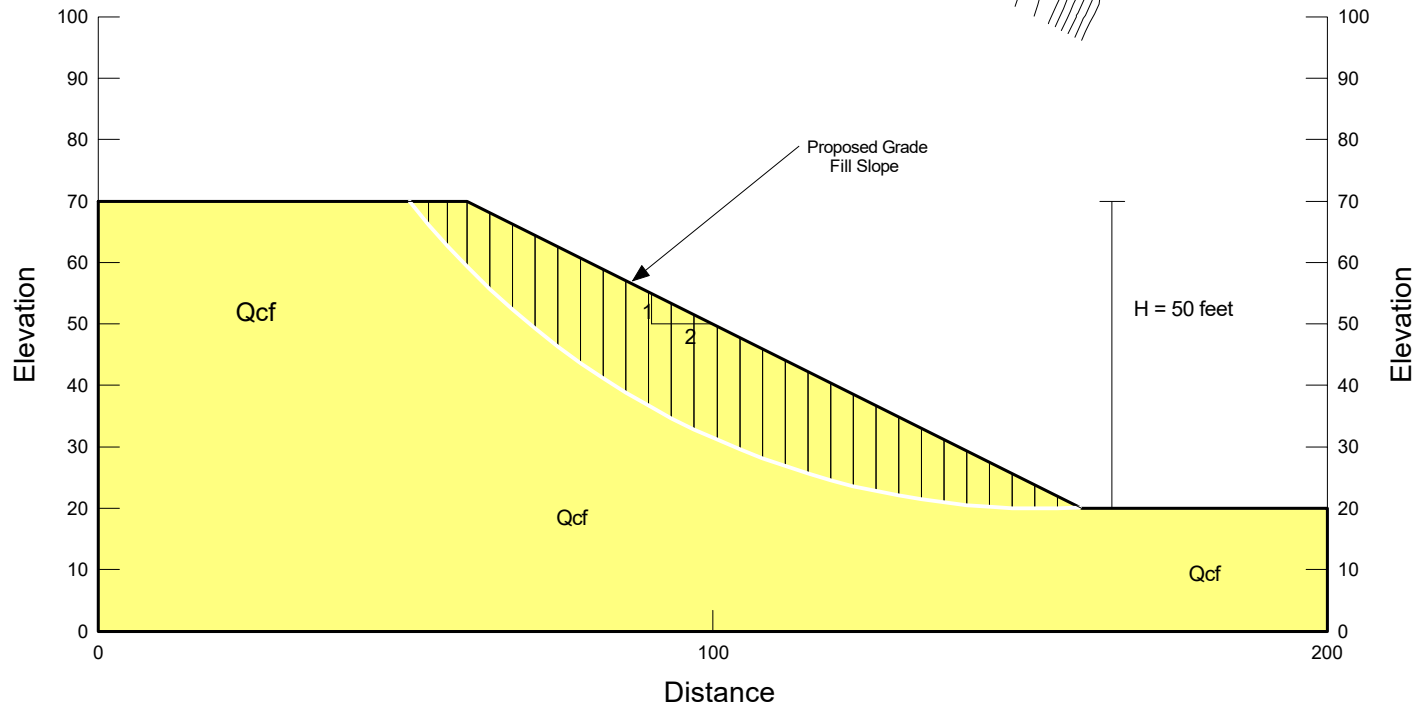
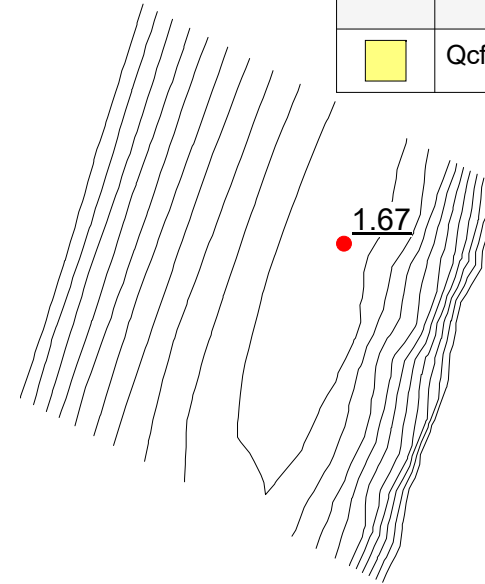

Project Name: Otay Ranch Village 8
 Project No. G1006-52-05

File Name: Cut Slope H=45.gsz
 Date: 09/28/2022, Time: 09:51:43 PM

Material Properties:

Color	Name	Unit Weight (pcf)	Cohesion' (psf)	Phi' (°)
	To	130	350	34

45 ft. High Cut Slope

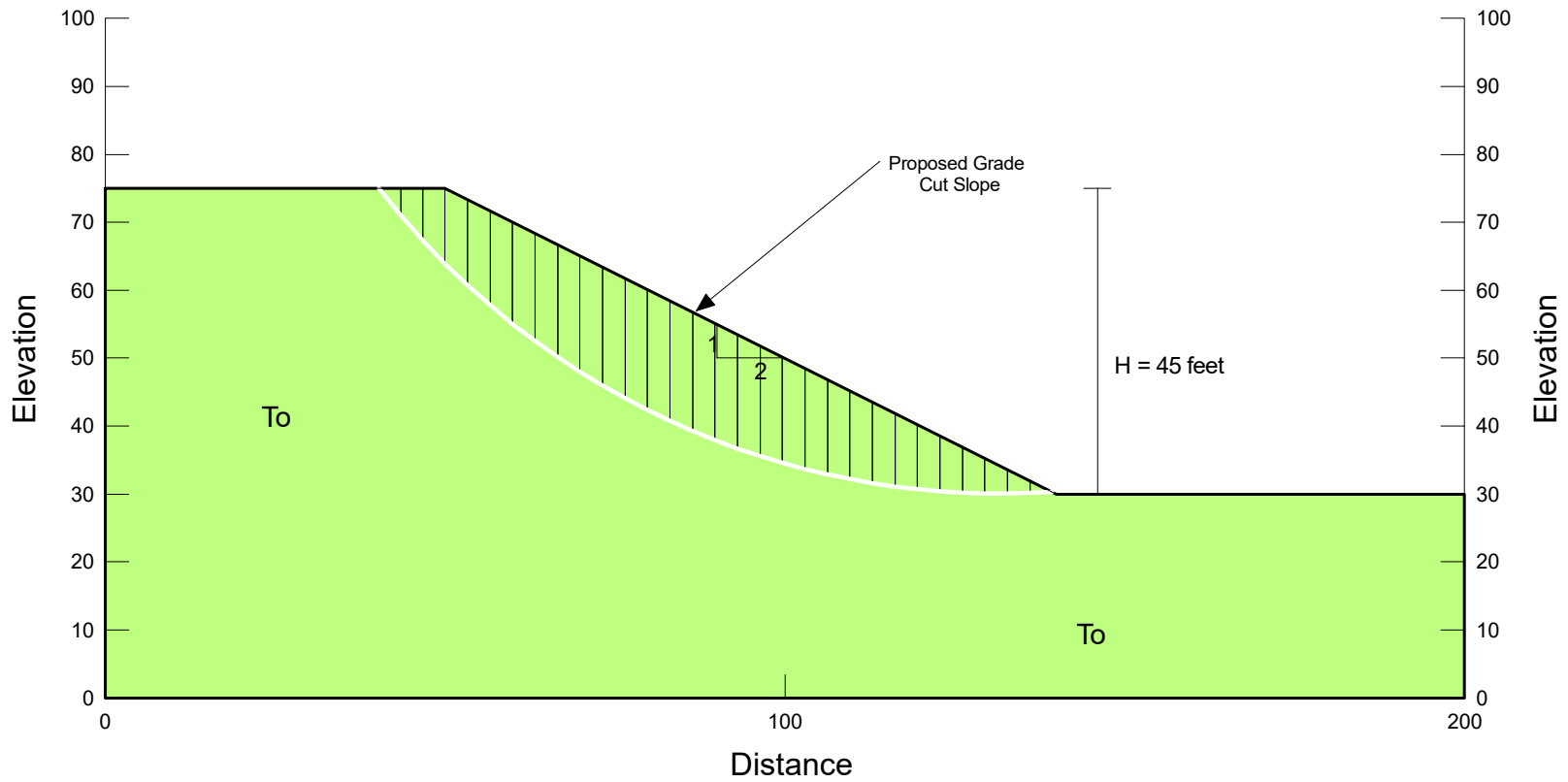
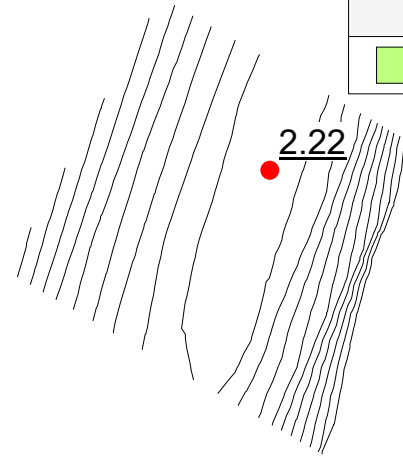

APPENDIX

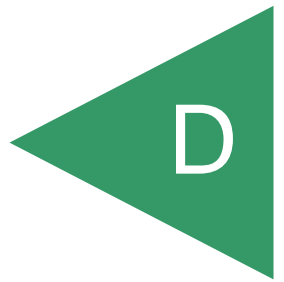

APPENDIX D

RECOMMENDED GRADING SPECIFICATIONS

FOR

OTAY RANCH VILLAGE 8 WEST
CHULA VISTA, CALIFORNIA

PROJECT NO. G1006-52-05

RECOMMENDED GRADING SPECIFICATIONS

1. GENERAL

- 1.1 These Recommended Grading Specifications shall be used in conjunction with the Geotechnical Report for the project prepared by Geocon. The recommendations contained in the text of the Geotechnical Report are a part of the earthwork and grading specifications and shall supersede the provisions contained hereinafter in the case of conflict.
- 1.2 Prior to the commencement of grading, a geotechnical consultant (Consultant) shall be employed for the purpose of observing earthwork procedures and testing the fills for substantial conformance with the recommendations of the Geotechnical Report and these specifications. The Consultant should provide adequate testing and observation services so that they may assess whether, in their opinion, the work was performed in substantial conformance with these specifications. It shall be the responsibility of the Contractor to assist the Consultant and keep them apprised of work schedules and changes so that personnel may be scheduled accordingly.
- 1.3 It shall be the sole responsibility of the Contractor to provide adequate equipment and methods to accomplish the work in accordance with applicable grading codes or agency ordinances, these specifications and the approved grading plans. If, in the opinion of the Consultant, unsatisfactory conditions such as questionable soil materials, poor moisture condition, inadequate compaction, and/or adverse weather result in a quality of work not in conformance with these specifications, the Consultant will be empowered to reject the work and recommend to the Owner that grading be stopped until the unacceptable conditions are corrected.

2. DEFINITIONS

- 2.1 **Owner** shall refer to the owner of the property or the entity on whose behalf the grading work is being performed and who has contracted with the Contractor to have grading performed.
- 2.2 **Contractor** shall refer to the Contractor performing the site grading work.
- 2.3 **Civil Engineer** or **Engineer of Work** shall refer to the California licensed Civil Engineer or consulting firm responsible for preparation of the grading plans, surveying and verifying as-graded topography.
- 2.4 **Consultant** shall refer to the soil engineering and engineering geology consulting firm retained to provide geotechnical services for the project.

- 2.5 **Soil Engineer** shall refer to a California licensed Civil Engineer retained by the Owner, who is experienced in the practice of geotechnical engineering. The Soil Engineer shall be responsible for having qualified representatives on-site to observe and test the Contractor's work for conformance with these specifications.
- 2.6 **Engineering Geologist** shall refer to a California licensed Engineering Geologist retained by the Owner to provide geologic observations and recommendations during the site grading.
- 2.7 **Geotechnical Report** shall refer to a soil report (including all addenda) which may include a geologic reconnaissance or geologic investigation that was prepared specifically for the development of the project for which these Recommended Grading Specifications are intended to apply.

3. MATERIALS

- 3.1 Materials for compacted fill shall consist of any soil excavated from the cut areas or imported to the site that, in the opinion of the Consultant, is suitable for use in construction of fills. In general, fill materials can be classified as *soil* fills, *soil-rock* fills or *rock* fills, as defined below.
- 3.1.1 **Soil fills** are defined as fills containing no rocks or hard lumps greater than 12 inches in maximum dimension and containing at least 40 percent by weight of material smaller than $\frac{3}{4}$ inch in size.
- 3.1.2 **Soil-rock fills** are defined as fills containing no rocks or hard lumps larger than 4 feet in maximum dimension and containing a sufficient matrix of soil fill to allow for proper compaction of soil fill around the rock fragments or hard lumps as specified in Paragraph 6.2. **Oversize rock** is defined as material greater than 12 inches.
- 3.1.3 **Rock fills** are defined as fills containing no rocks or hard lumps larger than 3 feet in maximum dimension and containing little or no fines. Fines are defined as material smaller than $\frac{3}{4}$ inch in maximum dimension. The quantity of fines shall be less than approximately 20 percent of the rock fill quantity.
- 3.2 Material of a perishable, spongy, or otherwise unsuitable nature as determined by the Consultant shall not be used in fills.
- 3.3 Materials used for fill, either imported or on-site, shall not contain hazardous materials as defined by the California Code of Regulations, Title 22, Division 4, Chapter 30, Articles 9

and 10; 40CFR; and any other applicable local, state or federal laws. The Consultant shall not be responsible for the identification or analysis of the potential presence of hazardous materials. However, if observations, odors or soil discoloration cause Consultant to suspect the presence of hazardous materials, the Consultant may request from the Owner the termination of grading operations within the affected area. Prior to resuming grading operations, the Owner shall provide a written report to the Consultant indicating that the suspected materials are not hazardous as defined by applicable laws and regulations.

- 3.4 The outer 15 feet of *soil-rock* fill slopes, measured horizontally, should be composed of properly compacted *soil* fill materials approved by the Consultant. *Rock* fill may extend to the slope face, provided that the slope is not steeper than 2:1 (horizontal:vertical) and a soil layer no thicker than 12 inches is track-walked onto the face for landscaping purposes. This procedure may be utilized provided it is acceptable to the governing agency, Owner and Consultant.
- 3.5 Samples of soil materials to be used for fill should be tested in the laboratory by the Consultant to determine the maximum density, optimum moisture content, and, where appropriate, shear strength, expansion, and gradation characteristics of the soil.
- 3.6 During grading, soil or groundwater conditions other than those identified in the Geotechnical Report may be encountered by the Contractor. The Consultant shall be notified immediately to evaluate the significance of the unanticipated condition.

4. CLEARING AND PREPARING AREAS TO BE FILLED

- 4.1 Areas to be excavated and filled shall be cleared and grubbed. Clearing shall consist of complete removal above the ground surface of trees, stumps, brush, vegetation, man-made structures, and similar debris. Grubbing shall consist of removal of stumps, roots, buried logs and other unsuitable material and shall be performed in areas to be graded. Roots and other projections exceeding 1½ inches in diameter shall be removed to a depth of 3 feet below the surface of the ground. Borrow areas shall be grubbed to the extent necessary to provide suitable fill materials.
- 4.2 Asphalt pavement material removed during clearing operations should be properly disposed at an approved off-site facility or in an acceptable area of the project evaluated by Geocon and the property owner. Concrete fragments that are free of reinforcing steel may be placed in fills, provided they are placed in accordance with Section 6.2 or 6.3 of this document.

- 4.3 After clearing and grubbing of organic matter and other unsuitable material, loose or porous soils shall be removed to the depth recommended in the Geotechnical Report. The depth of removal and compaction should be observed and approved by a representative of the Consultant. The exposed surface shall then be plowed or scarified to a minimum depth of 6 inches and until the surface is free from uneven features that would tend to prevent uniform compaction by the equipment to be used.
- 4.4 Where the slope ratio of the original ground is steeper than 5:1 (horizontal:vertical), or where recommended by the Consultant, the original ground should be benched in accordance with the following illustration.

TYPICAL BENCHING DETAIL

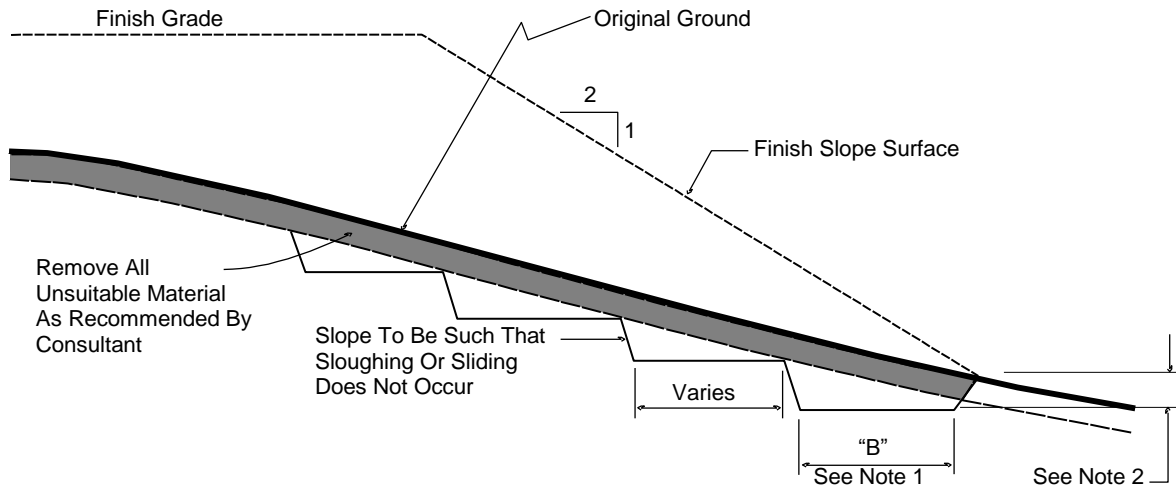

No Scale

- DETAIL NOTES:
- (1) Key width "B" should be a minimum of 10 feet, or sufficiently wide to permit complete coverage with the compaction equipment used. The base of the key should be graded horizontal, or inclined slightly into the natural slope.
 - (2) The outside of the key should be below the topsoil or unsuitable surficial material and at least 2 feet into dense formational material. Where hard rock is exposed in the bottom of the key, the depth and configuration of the key may be modified as approved by the Consultant.

- 4.5 After areas to receive fill have been cleared and scarified, the surface should be moisture conditioned to achieve the proper moisture content, and compacted as recommended in Section 6 of these specifications.

5. COMPACTION EQUIPMENT

- 5.1 Compaction of *soil* or *soil-rock* fill shall be accomplished by sheepsfoot or segmented-steel wheeled rollers, vibratory rollers, multiple-wheel pneumatic-tired rollers, or other types of acceptable compaction equipment. Equipment shall be of such a design that it will be capable of compacting the *soil* or *soil-rock* fill to the specified relative compaction at the specified moisture content.
- 5.2 Compaction of *rock* fills shall be performed in accordance with Section 6.3.

6. PLACING, SPREADING AND COMPACTION OF FILL MATERIAL

- 6.1 *Soil* fill, as defined in Paragraph 3.1.1, shall be placed by the Contractor in accordance with the following recommendations:
- 6.1.1 *Soil* fill shall be placed by the Contractor in layers that, when compacted, should generally not exceed 8 inches. Each layer shall be spread evenly and shall be thoroughly mixed during spreading to obtain uniformity of material and moisture in each layer. The entire fill shall be constructed as a unit in nearly level lifts. Rock materials greater than 12 inches in maximum dimension shall be placed in accordance with Section 6.2 or 6.3 of these specifications.
- 6.1.2 In general, the *soil* fill shall be compacted at a moisture content at or above the optimum moisture content as determined by ASTM D 1557.
- 6.1.3 When the moisture content of *soil* fill is below that specified by the Consultant, water shall be added by the Contractor until the moisture content is in the range specified.
- 6.1.4 When the moisture content of the *soil* fill is above the range specified by the Consultant or too wet to achieve proper compaction, the *soil* fill shall be aerated by the Contractor by blading/mixing, or other satisfactory methods until the moisture content is within the range specified.
- 6.1.5 After each layer has been placed, mixed, and spread evenly, it shall be thoroughly compacted by the Contractor to a relative compaction of at least 90 percent. Relative compaction is defined as the ratio (expressed in percent) of the in-place dry density of the compacted fill to the maximum laboratory dry density as determined in accordance with ASTM D 1557. Compaction shall be continuous over the entire area, and compaction equipment shall make sufficient passes so that the specified minimum relative compaction has been achieved throughout the entire fill.

- 6.1.6 Where practical, soils having an Expansion Index greater than 50 should be placed at least 3 feet below finish pad grade and should be compacted at a moisture content generally 2 to 4 percent greater than the optimum moisture content for the material.
 - 6.1.7 Properly compacted *soil* fill shall extend to the design surface of fill slopes. To achieve proper compaction, it is recommended that fill slopes be over-built by at least 3 feet and then cut to the design grade. This procedure is considered preferable to track-walking of slopes, as described in the following paragraph.
 - 6.1.8 As an alternative to over-building of slopes, slope faces may be back-rolled with a heavy-duty loaded sheepsfoot or vibratory roller at maximum 4-foot fill height intervals. Upon completion, slopes should then be track-walked with a D-8 dozer or similar equipment, such that a dozer track covers all slope surfaces at least twice.
- 6.2 *Soil-rock* fill, as defined in Paragraph 3.1.2, shall be placed by the Contractor in accordance with the following recommendations:
- 6.2.1 Rocks larger than 12 inches but less than 4 feet in maximum dimension may be incorporated into the compacted *soil* fill, but shall be limited to the area measured 15 feet minimum horizontally from the slope face and 5 feet below finish grade or 3 feet below the deepest utility, whichever is deeper.
 - 6.2.2 Rocks or rock fragments up to 4 feet in maximum dimension may either be individually placed or placed in windrows. Under certain conditions, rocks or rock fragments up to 10 feet in maximum dimension may be placed using similar methods. The acceptability of placing rock materials greater than 4 feet in maximum dimension shall be evaluated during grading as specific cases arise and shall be approved by the Consultant prior to placement.
 - 6.2.3 For individual placement, sufficient space shall be provided between rocks to allow for passage of compaction equipment.
 - 6.2.4 For windrow placement, the rocks should be placed in trenches excavated in properly compacted *soil* fill. Trenches should be approximately 5 feet wide and 4 feet deep in maximum dimension. The voids around and beneath rocks should be filled with approved granular soil having a Sand Equivalent of 30 or greater and should be compacted by flooding. Windrows may also be placed utilizing an "open-face" method in lieu of the trench procedure, however, this method should first be approved by the Consultant.

- 6.2.5 Windrows should generally be parallel to each other and may be placed either parallel to or perpendicular to the face of the slope depending on the site geometry. The minimum horizontal spacing for windrows shall be 12 feet center-to-center with a 5-foot stagger or offset from lower courses to next overlying course. The minimum vertical spacing between windrow courses shall be 2 feet from the top of a lower windrow to the bottom of the next higher windrow.
- 6.2.6 Rock placement, fill placement and flooding of approved granular soil in the windrows should be continuously observed by the Consultant.
- 6.3 *Rock* fills, as defined in Section 3.1.3, shall be placed by the Contractor in accordance with the following recommendations:
- 6.3.1 The base of the *rock* fill shall be placed on a sloping surface (minimum slope of 2 percent). The surface shall slope toward suitable subdrainage outlet facilities. The *rock* fills shall be provided with subdrains during construction so that a hydrostatic pressure buildup does not develop. The subdrains shall be permanently connected to controlled drainage facilities to control post-construction infiltration of water.
- 6.3.2 *Rock* fills shall be placed in lifts not exceeding 3 feet. Placement shall be by rock trucks traversing previously placed lifts and dumping at the edge of the currently placed lift. Spreading of the *rock* fill shall be by dozer to facilitate *seating* of the rock. The *rock* fill shall be watered heavily during placement. Watering shall consist of water trucks traversing in front of the current rock lift face and spraying water continuously during rock placement. Compaction equipment with compactive energy comparable to or greater than that of a 20-ton steel vibratory roller or other compaction equipment providing suitable energy to achieve the required compaction or deflection as recommended in Paragraph 6.3.3 shall be utilized. The number of passes to be made should be determined as described in Paragraph 6.3.3. Once a *rock* fill lift has been covered with *soil* fill, no additional *rock* fill lifts will be permitted over the *soil* fill.
- 6.3.3 Plate bearing tests, in accordance with ASTM D 1196, may be performed in both the compacted *soil* fill and in the *rock* fill to aid in determining the required minimum number of passes of the compaction equipment. If performed, a minimum of three plate bearing tests should be performed in the properly compacted *soil* fill (minimum relative compaction of 90 percent). Plate bearing tests shall then be performed on areas of *rock* fill having two passes, four passes and six passes of the compaction equipment, respectively. The number of passes required for the *rock* fill shall be determined by comparing the results of the plate bearing tests for the *soil* fill and the *rock* fill and by evaluating the deflection

variation with number of passes. The required number of passes of the compaction equipment will be performed as necessary until the plate bearing deflections are equal to or less than that determined for the properly compacted *soil* fill. In no case will the required number of passes be less than two.

- 6.3.4 A representative of the Consultant should be present during *rock* fill operations to observe that the minimum number of “passes” have been obtained, that water is being properly applied and that specified procedures are being followed. The actual number of plate bearing tests will be determined by the Consultant during grading.
- 6.3.5 Test pits shall be excavated by the Contractor so that the Consultant can state that, in their opinion, sufficient water is present and that voids between large rocks are properly filled with smaller rock material. In-place density testing will not be required in the *rock* fills.
- 6.3.6 To reduce the potential for “piping” of fines into the *rock* fill from overlying *soil* fill material, a 2-foot layer of graded filter material shall be placed above the uppermost lift of *rock* fill. The need to place graded filter material below the *rock* should be determined by the Consultant prior to commencing grading. The gradation of the graded filter material will be determined at the time the *rock* fill is being excavated. Materials typical of the *rock* fill should be submitted to the Consultant in a timely manner, to allow design of the graded filter prior to the commencement of *rock* fill placement.
- 6.3.7 *Rock* fill placement should be continuously observed during placement by the Consultant.

7. SUBDRAINS

- 7.1 The geologic units on the site may have permeability characteristics and/or fracture systems that could be susceptible under certain conditions to seepage. The use of canyon subdrains may be necessary to mitigate the potential for adverse impacts associated with seepage conditions. Canyon subdrains with lengths in excess of 500 feet or extensions of existing offsite subdrains should use 8-inch-diameter pipes. Canyon subdrains less than 500 feet in length should use 6-inch-diameter pipes.

TYPICAL CANYON DRAIN DETAIL

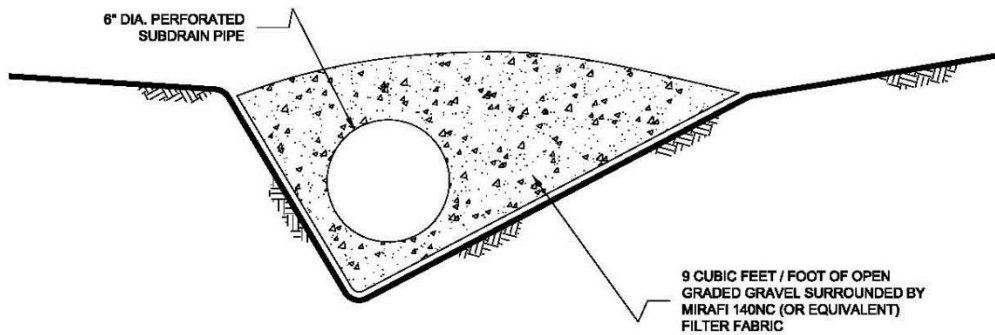
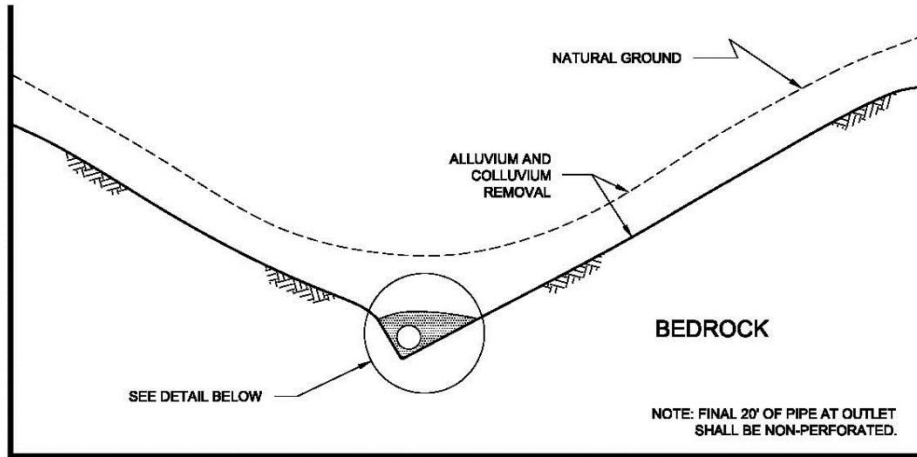

NOTES:

- 1.....8-INCH DIAMETER, SCHEDULE 80 PVC PERFORATED PIPE FOR FILLS IN EXCESS OF 100-FEET IN DEPTH OR A PIPE LENGTH OF LONGER THAN 500 FEET.
- 2.....6-INCH DIAMETER, SCHEDULE 40 PVC PERFORATED PIPE FOR FILLS LESS THAN 100-FEET IN DEPTH OR A PIPE LENGTH SHORTER THAN 500 FEET.

NO SCALE

7.2 Slope drains within stability fill keyways should use 4-inch-diameter (or larger) pipes.

TYPICAL STABILITY FILL DETAIL

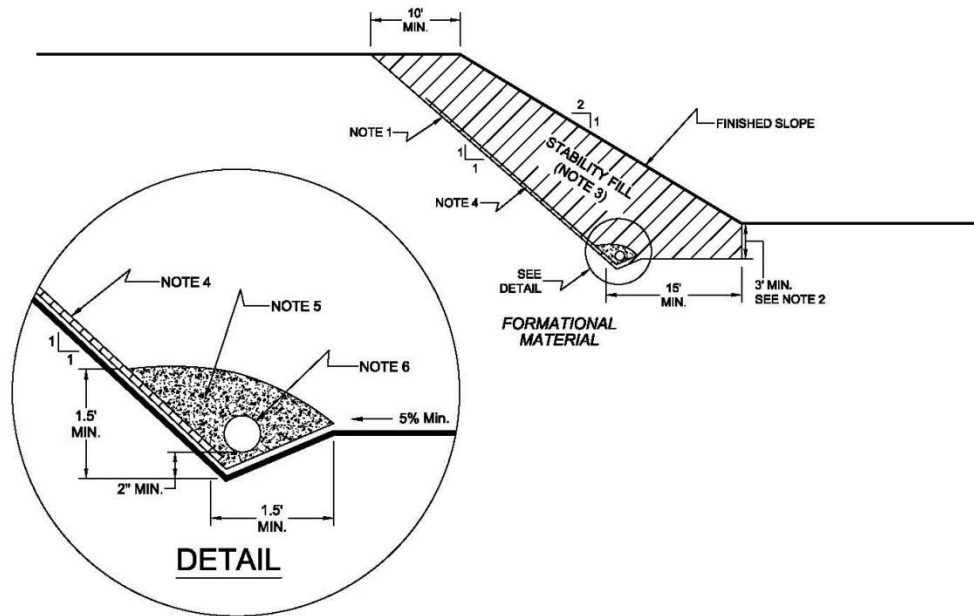

NOTES:

- 1.....EXCAVATE BACKCUT AT 1:1 INCLINATION (UNLESS OTHERWISE NOTED).
- 2.....BASE OF STABILITY FILL TO BE 3 FEET INTO FORMATIONAL MATERIAL, SLOPING A MINIMUM 5% INTO SLOPE.
- 3.....STABILITY FILL TO BE COMPOSED OF PROPERLY COMPACTED GRANULAR SOIL.
- 4.....CHIMNEY DRAINS TO BE APPROVED PREFABRICATED CHIMNEY DRAIN PANELS (MIRADRAIN G200N OR EQUIVALENT) SPACED APPROXIMATELY 20 FEET CENTER TO CENTER AND 4 FEET WIDE. CLOSER SPACING MAY BE REQUIRED IF SEEPAGE IS ENCOUNTERED.
- 5.....FILTER MATERIAL TO BE 3/4-INCH, OPEN-GRADED CRUSHED ROCK ENCLOSED IN APPROVED FILTER FABRIC (MIRAFI 140NC).
- 6.....COLLECTOR PIPE TO BE 4-INCH MINIMUM DIAMETER, PERFORATED, THICK-WALLED PVC SCHEDULE 40 OR EQUIVALENT, AND SLOPED TO DRAIN AT 1 PERCENT MINIMUM TO APPROVED OUTLET.

NO SCALE

7.3 The actual subdrain locations will be evaluated in the field during the remedial grading operations. Additional drains may be necessary depending on the conditions observed and the requirements of the local regulatory agencies. Appropriate subdrain outlets should be evaluated prior to finalizing 40-scale grading plans.

7.4 *Rock fill* or *soil-rock fill* areas may require subdrains along their down-slope perimeters to mitigate the potential for buildup of water from construction or landscape irrigation. The subdrains should be at least 6-inch-diameter pipes encapsulated in gravel and filter fabric. *Rock fill* drains should be constructed using the same requirements as canyon subdrains.

7.5 Prior to outletting, the final 20-foot segment of a subdrain that will not be extended during future development should consist of non-perforated drainpipe. At the non-perforated/perforated interface, a seepage cutoff wall should be constructed on the downslope side of the pipe.

TYPICAL CUT OFF WALL DETAIL

FRONT VIEW

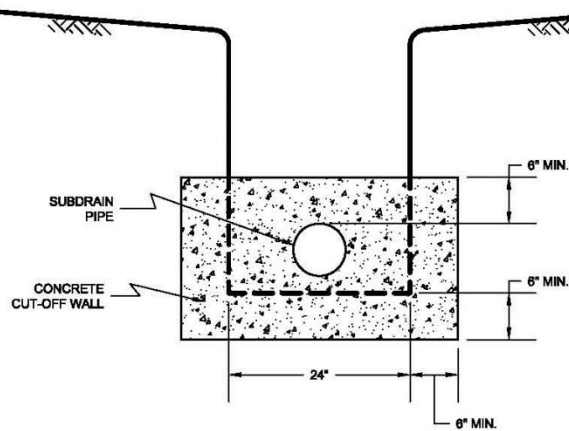

NO SCALE

SIDE VIEW

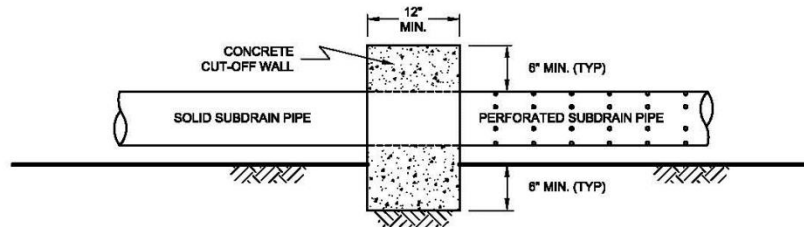

NO SCALE

7.6 Subdrains that discharge into a natural drainage course or open space area should be provided with a permanent headwall structure.

TYPICAL HEADWALL DETAIL

FRONT VIEW

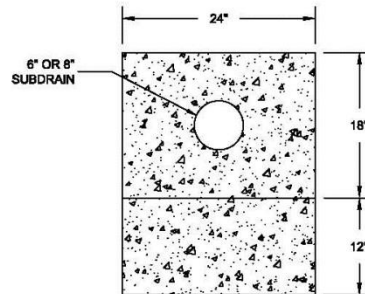

NO SCALE

SIDE VIEW

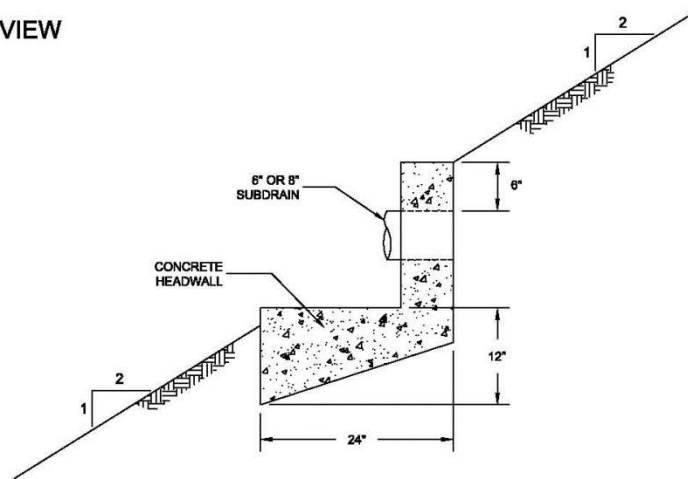

NOTE: HEADWALL SHOULD OUTLET AT TOE OF FILL SLOPE
OR INTO CONTROLLED SURFACE DRAINAGE

NO SCALE

- 7.7 The final grading plans should show the location of the proposed subdrains. After completion of remedial excavations and subdrain installation, the project civil engineer should survey the drain locations and prepare an “as-built” map showing the drain locations. The final outlet and connection locations should be determined during grading operations. Subdrains that will be extended on adjacent projects after grading can be placed on formational material and a vertical riser should be placed at the end of the subdrain. The grading contractor should consider videoing the subdrains shortly after burial to check proper installation and functionality. The contractor is responsible for the performance of the drains.

8. OBSERVATION AND TESTING

- 8.1 The Consultant shall be the Owner's representative to observe and perform tests during clearing, grubbing, filling, and compaction operations. In general, no more than 2 feet in vertical elevation of *soil* or *soil-rock* fill should be placed without at least one field density test being performed within that interval. In addition, a minimum of one field density test should be performed for every 2,000 cubic yards of *soil* or *soil-rock* fill placed and compacted.
- 8.2 The Consultant should perform a sufficient distribution of field density tests of the compacted *soil* or *soil-rock* fill to provide a basis for expressing an opinion whether the fill material is compacted as specified. Density tests shall be performed in the compacted materials below any disturbed surface. When these tests indicate that the density of any layer of fill or portion thereof is below that specified, the particular layer or areas represented by the test shall be reworked until the specified density has been achieved.
- 8.3 During placement of *rock* fill, the Consultant should observe that the minimum number of passes have been obtained per the criteria discussed in Section 6.3.3. The Consultant should request the excavation of observation pits and may perform plate bearing tests on the placed *rock* fills. The observation pits will be excavated to provide a basis for expressing an opinion as to whether the *rock* fill is properly seated and sufficient moisture has been applied to the material. When observations indicate that a layer of *rock* fill or any portion thereof is below that specified, the affected layer or area shall be reworked until the *rock* fill has been adequately seated and sufficient moisture applied.
- 8.4 A settlement monitoring program designed by the Consultant may be conducted in areas of *rock* fill placement. The specific design of the monitoring program shall be as recommended in the Conclusions and Recommendations section of the project Geotechnical Report or in the final report of testing and observation services performed during grading.
- 8.5 We should observe the placement of subdrains, to check that the drainage devices have been placed and constructed in substantial conformance with project specifications.
- 8.6 Testing procedures shall conform to the following Standards as appropriate:

8.6.1 Soil and Soil-Rock Fills:

- 8.6.1.1 Field Density Test, ASTM D 1556, *Density of Soil In-Place By the Sand-Cone Method.*

- 8.6.1.2 Field Density Test, Nuclear Method, ASTM D 6938, *Density of Soil and Soil-Aggregate In-Place by Nuclear Methods (Shallow Depth)*.
- 8.6.1.3 Laboratory Compaction Test, ASTM D 1557, *Moisture-Density Relations of Soils and Soil-Aggregate Mixtures Using 10-Pound Hammer and 18-Inch Drop*.
- 8.6.1.4. Expansion Index Test, ASTM D 4829, *Expansion Index Test*.

9. PROTECTION OF WORK

- 9.1 During construction, the Contractor shall properly grade all excavated surfaces to provide positive drainage and prevent ponding of water. Drainage of surface water shall be controlled to avoid damage to adjoining properties or to finished work on the site. The Contractor shall take remedial measures to prevent erosion of freshly graded areas until such time as permanent drainage and erosion control features have been installed. Areas subjected to erosion or sedimentation shall be properly prepared in accordance with the Specifications prior to placing additional fill or structures.
- 9.2 After completion of grading as observed and tested by the Consultant, no further excavation or filling shall be conducted except in conjunction with the services of the Consultant.

10. CERTIFICATIONS AND FINAL REPORTS

- 10.1 Upon completion of the work, Contractor shall furnish Owner a certification by the Civil Engineer stating that the lots and/or building pads are graded to within 0.1 foot vertically of elevations shown on the grading plan and that all tops and toes of slopes are within 0.5 foot horizontally of the positions shown on the grading plans. After installation of a section of subdrain, the project Civil Engineer should survey its location and prepare an *as-built* plan of the subdrain location. The project Civil Engineer should verify the proper outlet for the subdrains and the Contractor should ensure that the drain system is free of obstructions.
- 10.2 The Owner is responsible for furnishing a final as-graded soil and geologic report satisfactory to the appropriate governing or accepting agencies. The as-graded report should be prepared and signed by a California licensed Civil Engineer experienced in geotechnical engineering and by a California Certified Engineering Geologist, indicating that the geotechnical aspects of the grading were performed in substantial conformance with the Specifications or approved changes to the Specifications.

LIST OF REFERENCES

1. *2019 California Building Code, California Code of Regulations, Title 24, Part 2, based on the 2018 International Building Code*, prepared by California Building Standards Commission, dated July 2019.
2. *ACI 318-14, Building Code Requirements for Structural Concrete and Commentary on Building Code Requirements for Structural Concrete*, prepared by the American Concrete Institute, dated September 2014.
3. American Concrete Institute, *ACI 318-11, Building Code Requirements for Structural Concrete and Commentary*, dated August, 2011.
4. ASCE 7-16, *Minimum Design Loads and Associated Criteria for Buildings and Other Structures*, 2017.
5. California Geologic Survey (CGS), *Geologic Map of the Jamul Mountains 7.5' Quadrangle, San Diego County, California: A Digital Database, scale 1:24,000*, 2002.
6. California Geologic Survey, *Seismic Shaking Hazards in California*, Based on the USGS/CGS Probabilistic Seismic Hazards Assessment (PSHA) Model, 2002 (revised April 2003). 10% probability of being exceeded in 50 years.
<http://redirect.conservation.ca.gov/cgs/rghm/pshamap/pshamain.html>
7. Geocon Incorporated, *Geotechnical Investigation, Otay Ranch Village 4, Chula Vista, California*, prepared by Geocon Incorporated, dated July 19, 2019 (Project No. G1806-11-02).
8. Geocon Incorporated, *Update Geotechnical Investigation, Otay Ranch Village 3 North, and Village 4 Park Site, 40-Scale Grading Plan Submittal, Chula Vista, California*, prepared by Geocon Incorporated, dated April 21, 2016 (Project No. 06930-52-05).
9. Geotechnics, Incorporated, *Interim As-Graded Report, High School 13 Portion of McMillin Otay Ranch, Village 7, Chula Vista, California*, May 11, 2005.
10. *Geology and Mineral Resources of San Diego County, California*, California Division of
11. Todd, Victoria R., *Preliminary Geologic Map of the El Cajon 30' x 60' Quadrangle, Southern California*, USGS, Open File Report 2004-1361, Scale 1:100,000, 2004.
12. Structural Engineers Association of California (SEAOC) and Office of Statewide Health Planning and Development (OSHPD), *Seismic Design Maps*, <https://seismicmaps.org/>, accessed January 11, 2019.
13. United States Geological Survey, *2002 Interactive Deaggregations*, <http://eqint.cr.usgs.gov/deaggint/2002/index.php>
14. Unpublished Geotechnical Reports and Information, Geocon Incorporated.
15. USGS computer program, *Seismic Hazard Curves and Uniform Hazard Response Spectra*, <http://earthquake.usgs.gov/research/hazmaps/design/>
16. Walsh, Stephen L., and Demere, Thomas A., 1991, *Age and Stratigraphy of the Sweetwater and Otay Formations, San Diego County California*, In Abbott, P. L. and May, J. A., eds., 1991, Eocene Geologic history San Diego Region, Pacific section SEPM, Vol. 68, p. 131-148.